

GD Midea Refrigeration Equipment Co.,Ltd

SPLIT TYPE, HEAT PUMP AIR CONDITIONERS

WEBSITE:www.mideaaircom.com

Room Air Conditioner

Technical & service manual

Portable F Series Mechanical type

[Models]

Electronic Control

MPF-09CEN2 MPF-09EEN2

MPF-12CEN2 MPF-12EEN2

Remote Control

MPF-09CRN2 MPF-09ERN2

MPF-12CRN2 MPF-12ERN2

Content

1.	Precaution	1
1.1	Safety Precaution.....	1
1.2	Warning.....	1
1.3	Caution.....	1
2.	Characteristics	2
2.1	Structural characteristics	2
2.2	Performance characteristics	2
3.	Dimension	2
All the models here have the same dimension.....		2
4.	Specification	3
5.	Refrigerant cycle diagram	7
6.	Operation limits	8
6.1	Cooling operation.....	8
6.2	Heating operation.....	8
7.	Schematic diagram and Wiring diagram	9
7.1.	Schematic diagram	9
7.2.	Wiring diagram.....	10
8.	Electronic function	12

1. Precaution

1.1 Safety Precaution

1.1.1 To prevent injury to the user or other people and property damage, the following instructions must be followed.

1.1.2 Incorrect operation due to ignoring instruction will cause harm or damage.

1.1.3 Before service unit, be sure to read this service manual at first.

1.2 Warning

Installation

1.2.1 Do not use damaged power cords, plugs, or a loose socket.

1.2.2 Always use the power plug and socket with the ground terminal

1.2.3 Do not modify or extend the power cord

1.2.4 Do not turn the air-conditioner ON or OFF by plugging or unplugging the power plug

1.2.5 Use a dedicated outlet for this appliance

1.2.6 Grasp the plug to remove the cord from the outlet. Do not touch it with wet hands.

1.2.7 Do not place a heater or other appliance near the power cable

1.2.8 Do not allow water to run into electrical parts

1.2.9 Do not store or use flammable gas or combustibles near the air conditioner

1.2.10 Unplugging the unit if strange sounds, odors, or smoke comes from it

1.2.11 Be caution that water could not enter the product

1.3 Caution

Installation

1.3.1 Keep level even when installing the product

1.3.2 Use two or more people to lift and transport the air conditioner

Operation

1.3.3 Use a soft cloth to clean. Do not use harsh detergents, solvents, etc

1.3.4 Do not touch the metal parts of the product when removing the air filter. They are very sharp

1.3.5 Do not step on or put anything on the product

1.3.6 Do not insert hands or other objects through the air inlet or outlet while the air conditioner is plugged in

2. Characteristics

2.1 Structural characteristics

2.1.1 There are four casters on the bottom for easy movement.

2.1.2 There is only one exhaust pipe(the length is from 0.5 to 2m), which makes the A/C easier to use.

2.1.3 The condensate is received by large volume container, which is convenient to use.

2.2 Performance characteristics

2.2.1 Compressors of famous brands are adopted for reliability and low noise.

2.2.2 The products have multiple uses: dehumidifying and cloth drying.

2.2.3 There is no need for special installation; they can be moved around for simple and convenient use.

2.2.4 The heating system uses PTC electrical heater and will not be affected by ambient temperature, which saves energy.

2.2.5 They are suitable for local cooling and heating.

3. Dimension



Dimension Mode	W	H	D
Net Dimension	465	830	387
Packing Dimension	667	887	460

All the models here have the same dimension.

4. Specification

Model		MPF-09CEN2	MPF-09CRN2	MPF-09EEN2	MPF-09ERN2
Control Method		Electric	Remote	Electric	Remote
Nameplate marking					
Power supply	Ph-V-Hz	1φ,220-240V~,50Hz		1φ,220-240V~,50Hz	
Capacity ¹	Btu/h	9000		9000	
Power consumption ¹	W	1090		1090	
Rated current ¹	A	4.9		4.9	
EER ¹	W/W	2.41		2.41	
EEC ²		C		C	
Electrical heater	W	-----		1700	
System data					
Refrigerant type	g	R407C/500		R407C/500	
Design pressure (Hi/Lo)	Mpa	2.6		2.6	
Moisture Removal	L/h	1.8		1.8	
Water tank volume	L	inner water tank 3.5L		inner water tank 3.5L	
Indoor air flow (Hi/Mi/Lo)	m3/h	340/270/210		340/270/210	
Noise level (Hi/Mi/Lo)	dB(A)	53/51/49		53/51/49	
Dimension&Weight					
Dimension (W*H*D)	mm	480×840×400		480×840×400	
Packing (W*H*D)	mm	655×875×445		655×875×445	
Net/Gross weight	Kg	37/41		37/41	
Applicable ambient					
Operation temp	℃	17-30		17-30	
Ambient temp	℃	10-35		≤35	
Application area	m2	12-20		12-20	
Water Pump					
Current	mA	90		90	
Input	W	16		16	
Water flow	ml/min	70		70	
Height lift	m	4		4	
Compressor					
Model		PG150X1C-4DZDE2		PG150X1C-4DZDE2	
Type		Rotary		Rotary	
Brand		GMCC		GMCC	
Capacity	W	2575/2610		2575/2610	
Input	W	840/880		840/880	
Rated current(RLA)	A	3.9/3.8		3.9/3.8	
Locked rotor Amp(LRA)	A	21.7/23.7		21.7/23.7	
Thermal protector		B160-135-241E/MRA13430-9087		B160-135-241E/MRA13430-9087	
Capacitor	uF	25uF/ 370V		25uF/ 370V	
Refrigerant oil	cc	400		400	
Fan Motor					
Model		YDK80-4M		YDK80-4M	

Service manual

Input	W	181/151/107/93	181/151/107/93
Capacitor	uF	6uF/450V	6uF/450V
Speed(hi/mi/lo)	r/min	1230/1110/880/800	1230/1110/880/800
Evap.			
a.Number of rows		2	2
b.Tube pitch(a)x row pitch(b)	mm	21X13.37	21X13.37
c.Fin spacing	mm	1.4	1.4
d.Fin type (code)		Hydrophilic aluminium	Hydrophilic aluminium
e.Tube outside dia.and type	mm	Φ7×0.25×0.18, innergroove tube	Φ7×0.25×0.18, innergroove tube
f.Coil length x height x width	mm	335x294x26.74	335x294x26.74
g.Number of circuits		2	2
Cond.			
a.Number of rows		2	2
b.Tube pitch(a)x row pitch(b)	mm	21X13.37	21X13.37
c.Fin spacing	mm	1.4	1.4
d.Fin type (code)		Unhydrophilic aluminium	Unhydrophilic aluminium
e.Tube outside dia.and type	mm	Φ7×0.25×0.18, innergroove tube	Φ7×0.25×0.18, innergroove tube
f.Coil length x height x width	mm	542x294x13.37 519x294x13.37	542x294x13.37 519x294x13.37
g.Number of circuits		2	2
Stuffing Quantity			
20'/40'40'HQ	set	86/176/269	86/176/269

1 The test condition is according to EN14511 standard at application rating conditions.

2 EEC (Energy efficiency class). The test condition is according to EN14511 standard at standard condition.

Model		MPF-12CEN2	MPF-12CRN2	MPF-12EEN2	MPF-12ERN2
Control Method		Electric	Remote	Electric	Remote
Nameplate marking					
Power supply	Ph-V-Hz	1φ,220-240V~,50Hz		1φ,220-240V~,50Hz	
Capacity ¹	Btu/h	11500		11500	
Power consumption ¹	W	1380		1380	
Rated current ¹	A	5.4		5.4	
EER ¹	W/W	2.42		2.42	
EEC ²		C		C	
Electrical heater	W	-----		1700	
System data					
Refrigerant type	g	R407C/560		R407C/560	
Design pressure (Hi/Lo)	Mpa	2.6		2.6	
Moisture Removal	L/h	2		2	
Water tank volume	L	inner water tank 3.5L		inner water tank 3.5L	
Indoor air flow (Hi/Mi/Lo)	m3/h	340/270/210		340/270/210	
Noise level (Hi/Mi/Lo)	dB(A)	53/51/49		53/51/49	

Dimension&Weight			
Dimension (W*H*D)	mm	480×840×400	480×840×400
Packing (W*H*D)	mm	655×875×445	655×875×445
Net/Gross weight	Kg	34/44	34/44
Applicable ambient			
Operation temp	°C	17-30	17-30
Ambient temp	°C	10-35	≤35
Application area	m2	15-22	15-22
Water Pump			
Current	mA	90	90
Input	W	16	16
Water flow	ml/min	70	70
Height lift	m	4	4
Compressor			
Model		PG180X1C-4DZDE3	PG180X1C-4DZDE3
Type		Rotary	Rotary
Brand		GMCC	GMCC
Capacity	W	3120/3150	3120/3150
Input	W	995/1030	995/1030
Rated current(RLA)	A	4.6/4.4	4.6/4.4
Locked rotor Amp(LRA)	A	19.8	19.8
Thermal protector		B160-135-141E	B160-135-141E
Capacitor	uF	30uF/ 370V	30uF/ 370V
Refrigerant oil	cc	400	400
Compressor(alternative)			
Model		CG633PB1-C	CG633PB1-C
Type		Rotary	Rotary
Brand		Hitachi	Hitachi
Capacity	W	2850	2850
Input	W	970	970
Rated current(RLA)	A	4.6	4.6
Locked rotor Amp(LRA)	A	17.4	17.4
Thermal protector			
Capacitor	uF	35uF/ 400V	35uF/ 400V
Refrigerant oil	cc	400	400
Fan Motor			
Model		YDK80-4M	YDK80-4M
Input	W	181/151/107/93	181/151/107/93
Capacitor	uF	6uF/450V	6uF/450V
Speed(hi/mi/lo)	r/min	1230/1110/880/800	1230/1110/880/800
Evap.			
a.Number of rows		2	2
b.Tube pitch(a)x row pitch(b)	mm	21X13.37	21X13.37
c.Fin spacing	mm	1.4	1.4

Service manual

d.Fin type (code)		Hydrophilic aluminium	Hydrophilic aluminium
e.Tube outside dia.and type	mm	Φ7×0.25×0.18, innergroove tube	Φ7×0.25×0.18, innergroove tube
f.Coil length x height x width	mm	380x294x26.74	380x294x26.74
g.Number of circuits		2	2
Cond.			
a.Number of rows		2	2
b.Tube pitch(a)x row pitch(b)	mm	21X13.37	21X13.37
c.Fin spacing	mm	1.4	1.4
d.Fin type (code)		Unhydrophilic aluminium	Unhydrophilic aluminium
e.Tube outside dia.and type	mm	Φ7×0.25×0.18, innergroove tube	Φ7×0.25×0.18, innergroove tube
f.Coil length x height x width	mm	704x294x13.37 660x294x13.37	704x294x13.37 660x294x13.37
g.Number of circuits		2	2
Stuffing Quantity			
20'40'40'HQ	set	86/176/269	86/176/269

1 The test condition is according to EN14511 standard at application rating conditions.

2 EEC (Energy efficiency class). The test condition is according to EN14511 standard at standard condition.

5. Refrigerant cycle diagram

The figure below is a brief description of the important components and their function in what is called the refrigeration system.

This will help to understand the refrigeration cycle and the flow of the refrigerant in the cooling cycle.

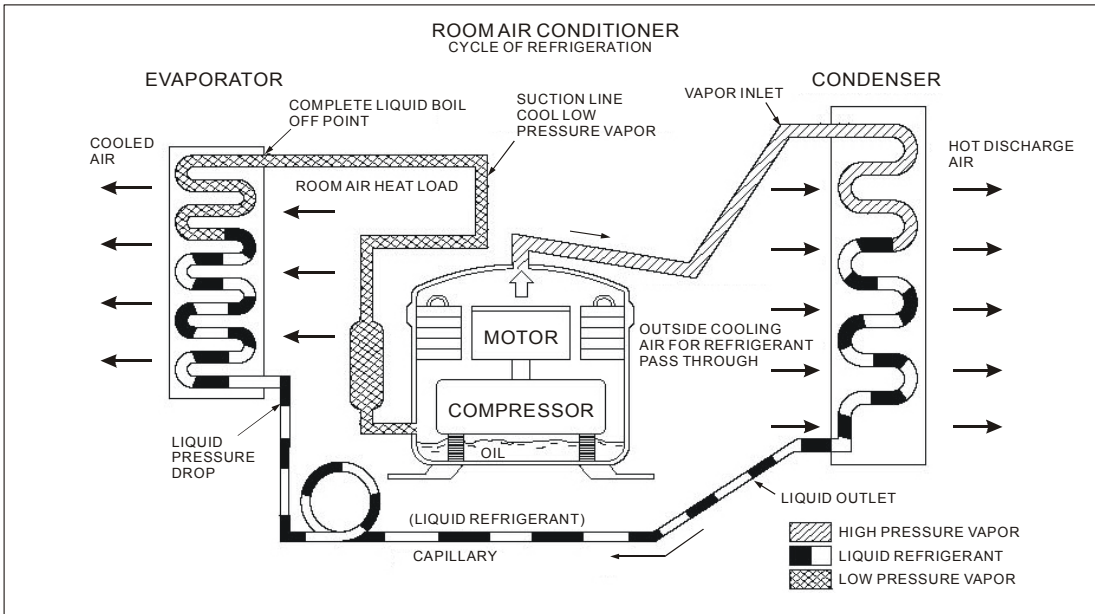

6. Operation limits

6.1 Cooling operation

Outdoor unit air temp. °C DB

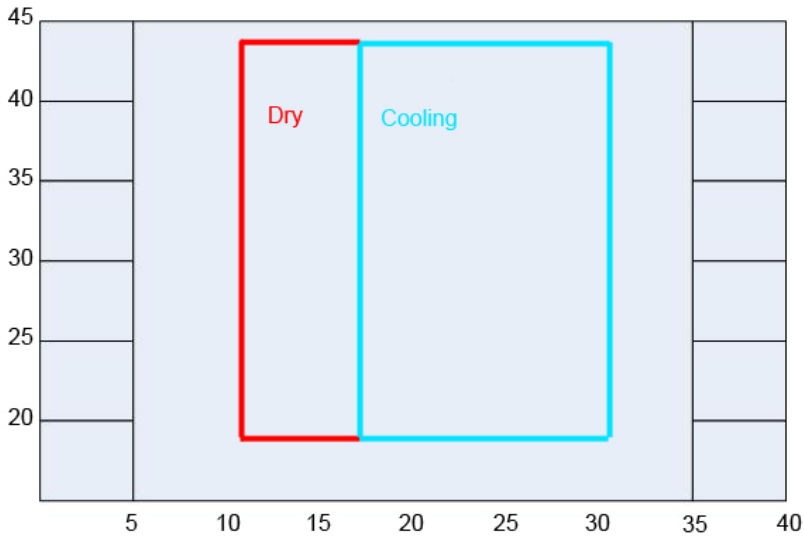

Indoor air temp. °C DB

Note: The chart is the result from the continuous operation under constant air temperature conditions. However, excludes the initial pull-down stage.

6.2 Heating operation

Indoor air temp. °C DB

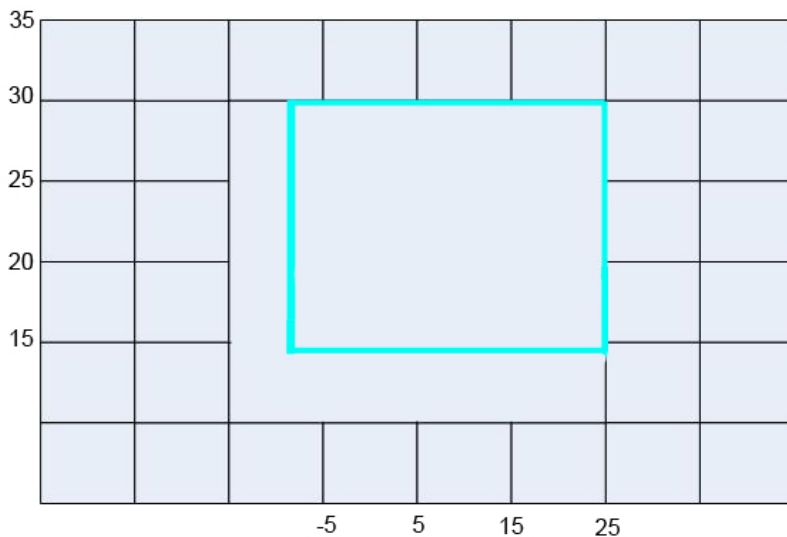

Outdoor unit air temp. °C DB

Note: The chart is the result from the continuous operation under constant air temperature conditions. However, excludes the initial pull-down stage.

7.2. Wiring diagram

MPF-09CEN2, MPF-09CRN2, MPF-10CEN2, MPF-10CRN2

MPF-09CEN2, MPF-09CRN2, MPF-14CEN2, MPF-14CRN2

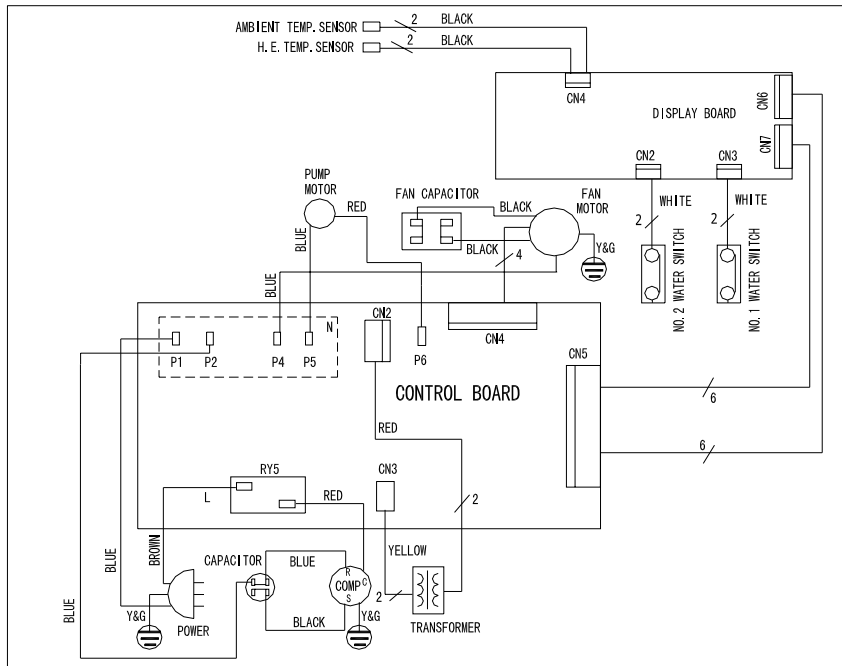

MPF-09EEN2, MPF-09ERN2, MPF-10EEN2, MPF-10ERN2

MPF-12EEN2, MPF-12ERN2, MPF-14EEN2, MPF-14ERN2

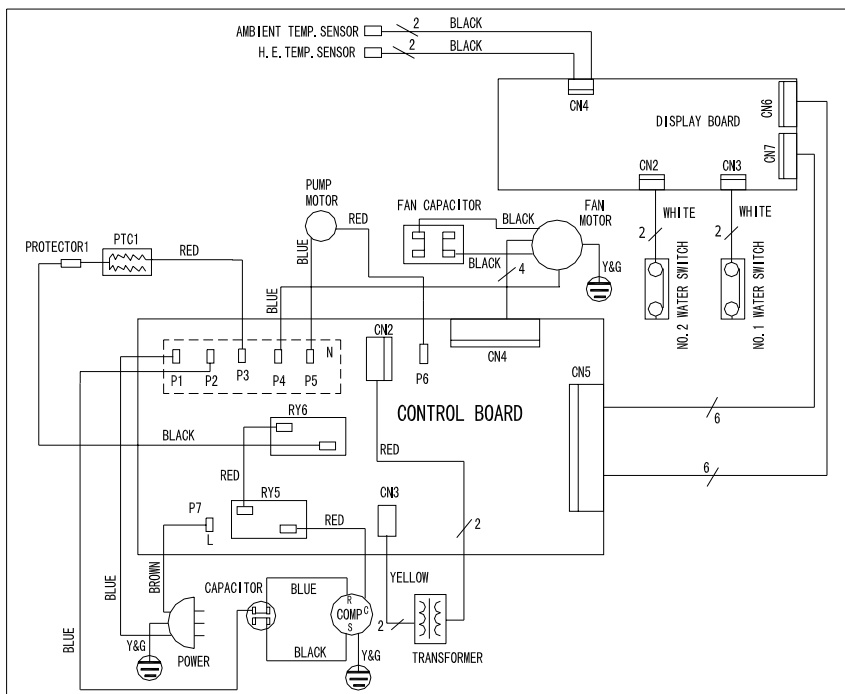

MPF-09CE, MPF-09CR, MPF-10CE, MPF-12CR, MPF-12CE, MPF-12CR

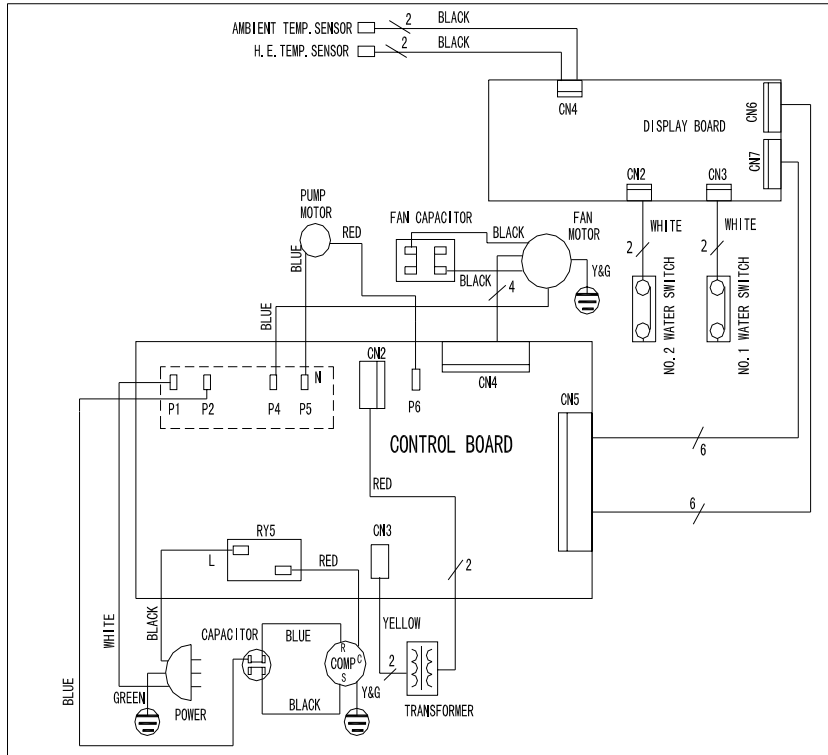

MPF-09EE, MPF-09ER, MPF-10EE, MPF-10ER, MPF-12EE, MPF-12ER

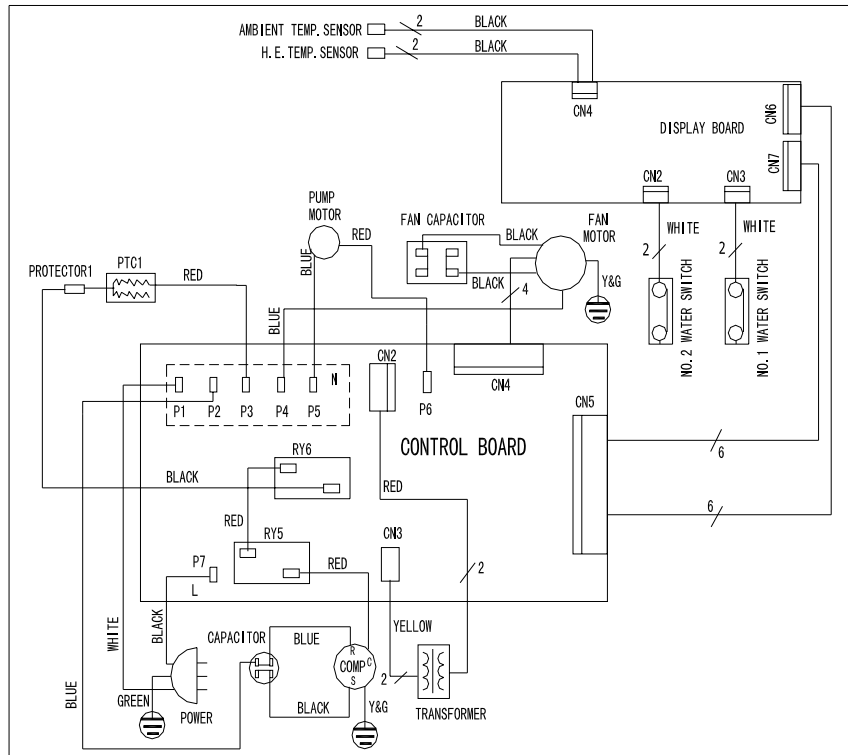

8. Electronic function

8.1 Cooling mode

The air flow speed can be set at high, medium and low.

The temperature can be set from 17°C~30°C.

The action of the compressor

	Condition	Compressor
Temp. up	$T > T_s + 1$	On
	$T < T_s + 1$	Off
Temp. down	$T > T_s$	On
	$T < T_s$	Off

8.2 Heating mode

The air flow speed can be set at high or low;

The temperature can be set from 17°C~30°C.

The action of the PTC heater:

	Condition	PTC heater
Temp. up	$T > T_s + 1$	Off
	$T < T_s + 1$	On
Temp. down	$T > T_s$	Off
	$T < T_s$	On

8.3 Dehumidifying mode

The fan works at High speed.

The action of the compressor

	Condition	Compressor
	Ta: room temp.	
Temp. up	$T_a > 15^\circ\text{C}$	On
	$T < 15^\circ\text{C}$	Off
Temp. down	$T_a > 13^\circ\text{C}$	On
	$T < 13^\circ\text{C}$	Off

8.4 Air blowing mode

The fan can run at high, medium or low speed.

8.5 Timer

8.5.1 Timer On

Push the **Timer On** button to start the timer;

Time is relative time, from

0.5-1.0-1.5-2.0-2.5-3.0-3.5-4.0-4.5-5.0-5.5-6.0-6.5-7.0-7.5-8.0-8.5-9.0-9.5-10-11-12-13-14-15-16-17-18-19-20-21-22-23-24-0.0;

8.5.2 Timer Off

Push the **Timer On** button to start the timer;

Time is relative time, from

0.5-1.0-1.5-2.0-2.5-3.0-3.5-4.0-4.5-5.0-5.5-6.0-6.5-7.0-7.5-8.0-8.5-9.0-9.5-10-11-12-13-14-15-16-17-18-19-20-21-22-23-24-0.0;

8.6 Operation panel

8.6.1 With PTC model

OPERATION PANEL OF THE AIR CONDITIONER(COOLING AND HEATING)

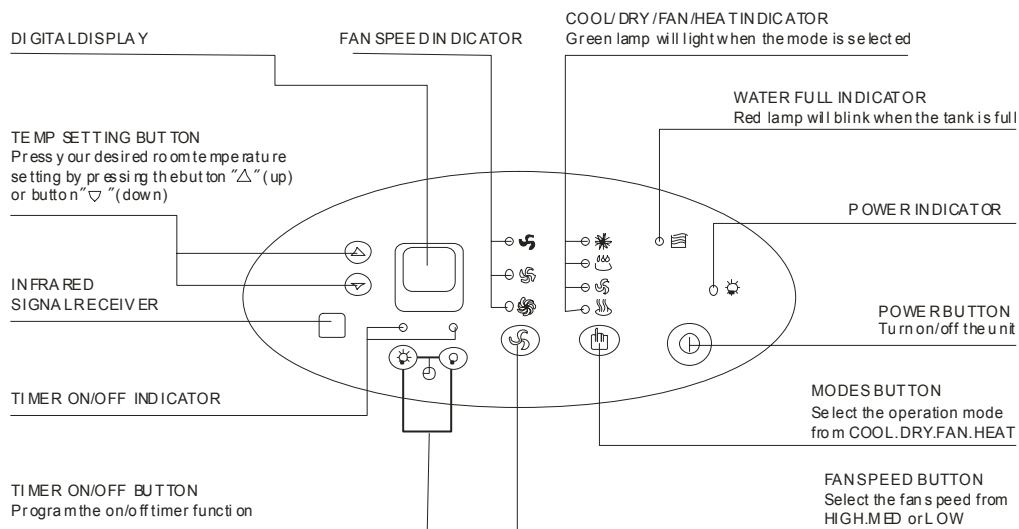

8.6.2 Without PTC model

OPERATION PANEL OF THE AIR CONDITIONER(COOLING ONLYTYPE)

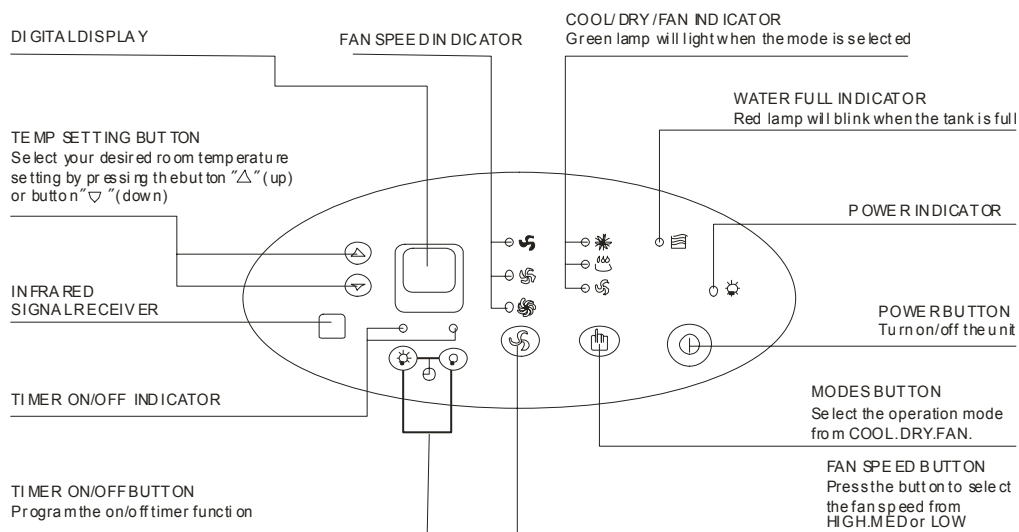

8.7 Protective function

8.7.1 Alarm on water level

At any mode, when the water level is up to the limit, the LED display 'P1', the alarm lamp flashes at 2 Hz, and the machine enters into air blowing mode.

8.7.2 Low temperature protection for the evaporator

At cooling and dehumidifying modes, if the pipe temperature is lower than 2°C after compressor runs for 3 minutes, the compressor will be shut down instantly. When the pipe temperature goes up to 10°C, the compressor runs again.

8.7.3 High temperature protection

At heating mode, when the temperature at air outlet is more 75°C, the PTC will be turned off; the lamp of heating will flash at 2Hz, when the temperature lowers to 55°C, the PTC returns to work.

At heating mode, when the temperature at air outlet is more 90°C, the fuse of PTC will be broken.

8.7.4 The delayed protection for compressor

When the power is on for the first time, the compressor starts without waiting for 3 minutes; re-starting the machine after the compressor is stopped needs to wait for 3 minutes.

8.7.5 Sensor defective protection

When the sensor is defective, the unit will display the error.

Pipe temp. sensor error code: E1

Room temp. sensor error code: E2

9. Malfunction and troubleshooting

a. No display or no response to remote controller or no response to button ..

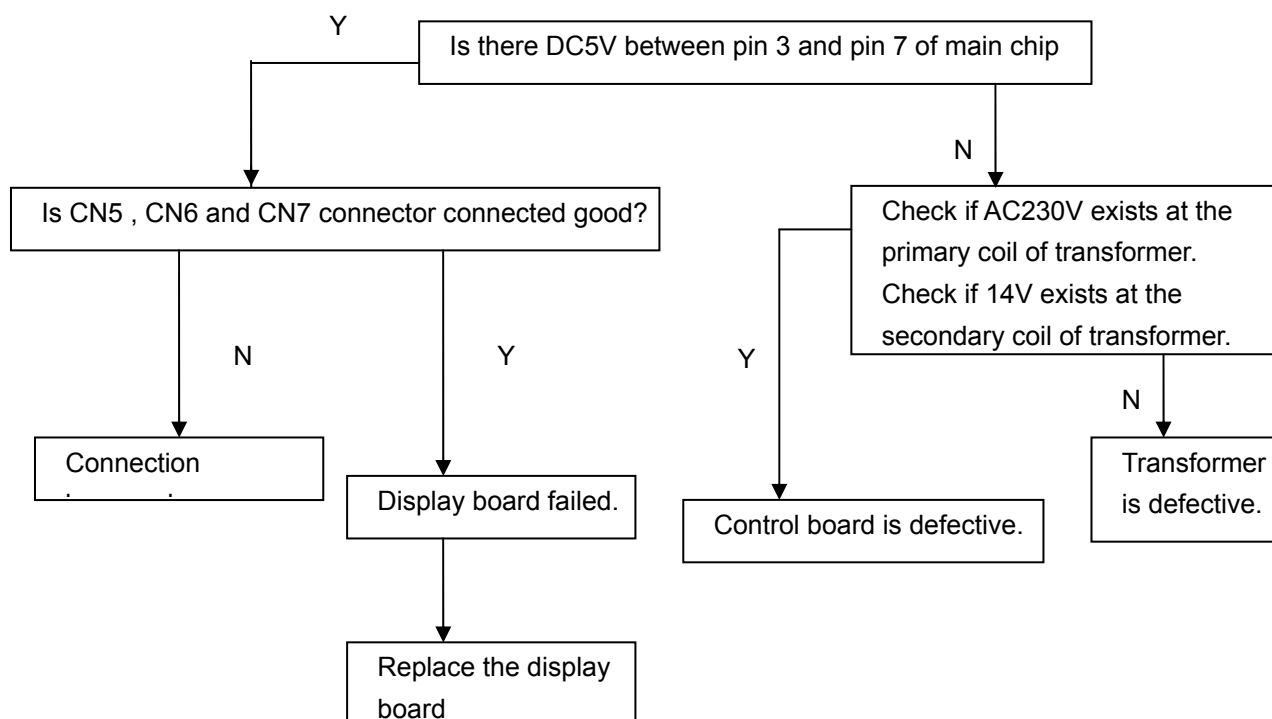

b. No fan running.

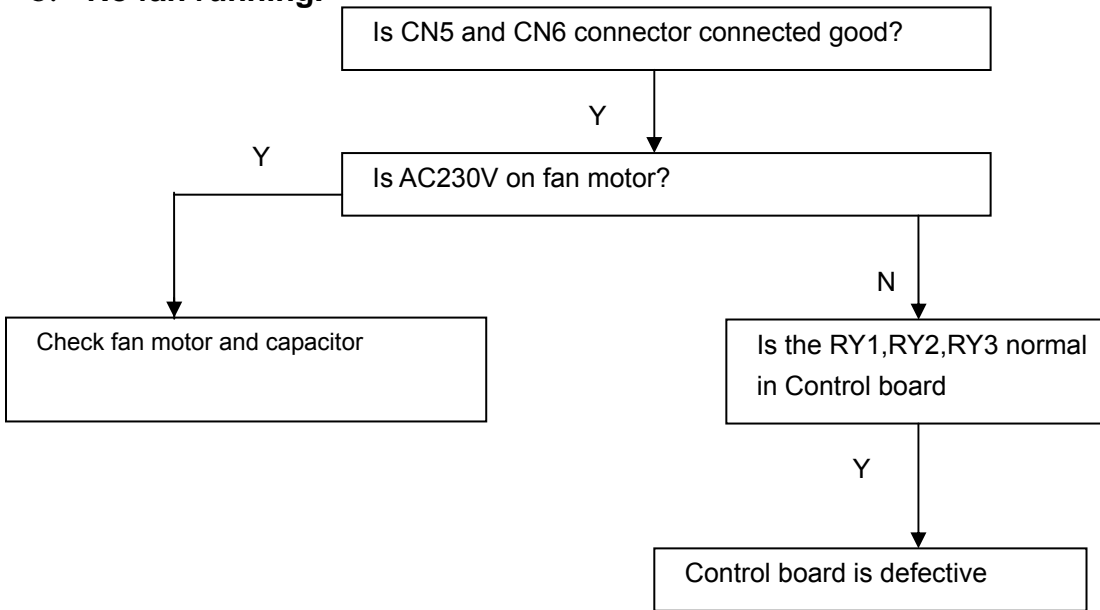

c. No compressor working.

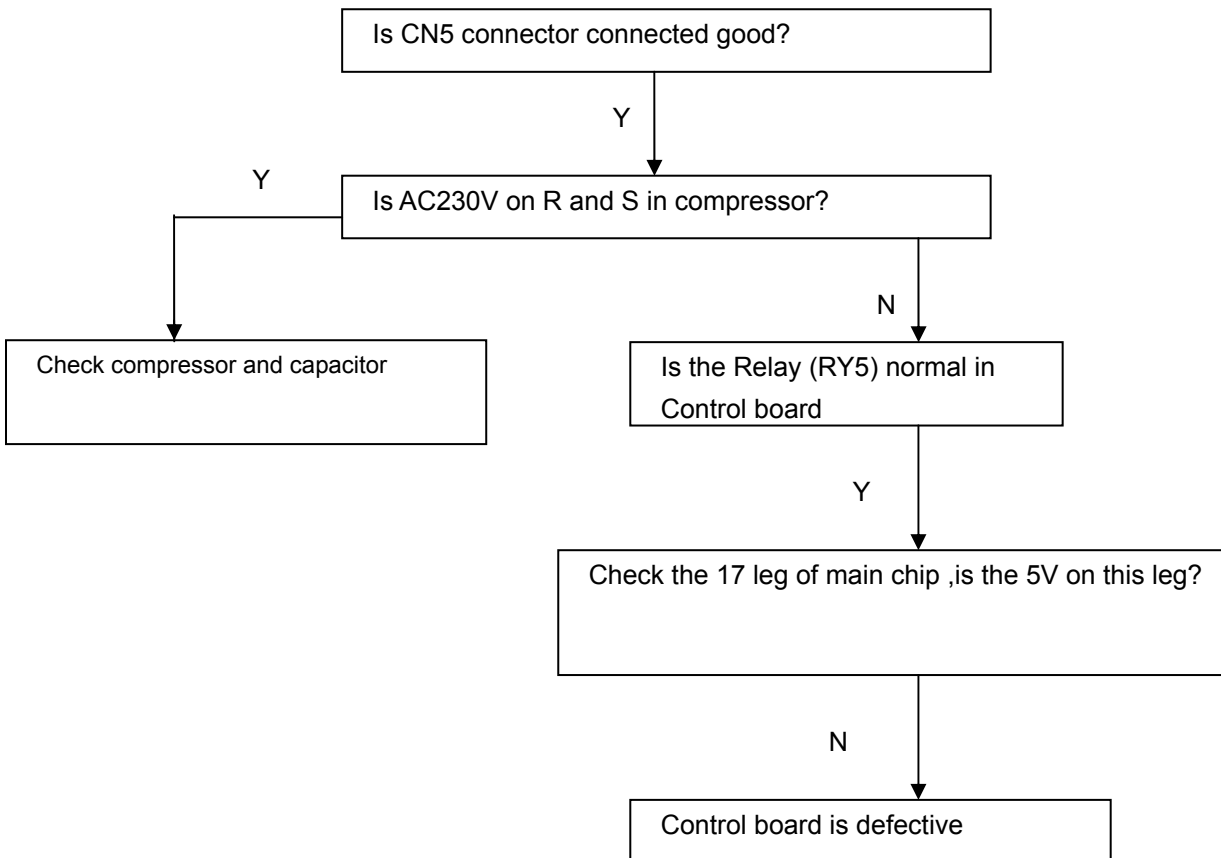

d. No water pump running.

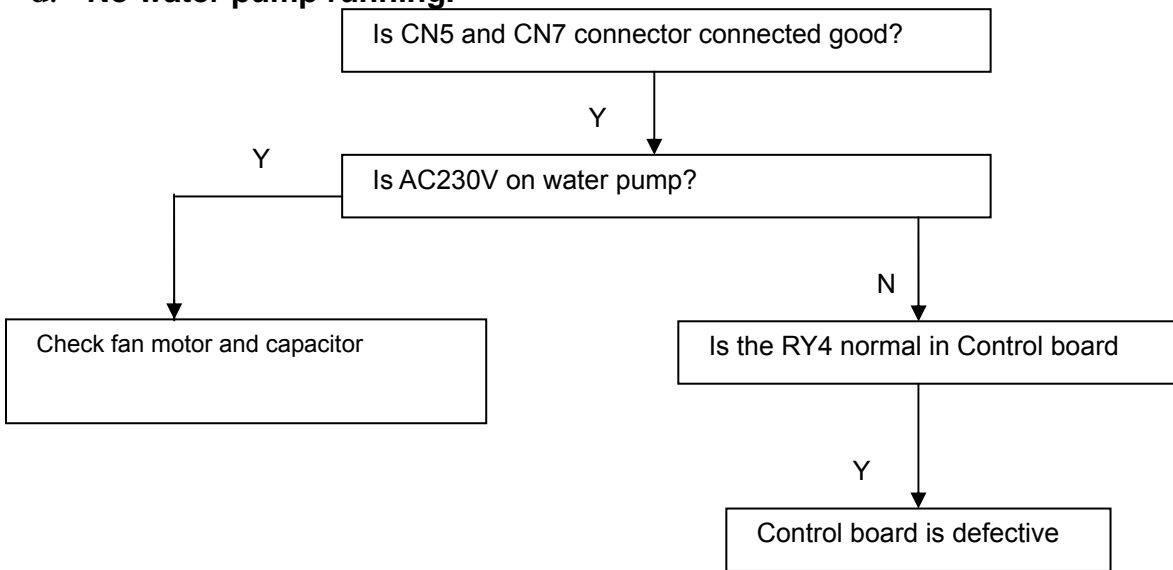

e. No PTC working(only for with PTC heater model).

Set temperature at 32°C and make sure the room temperature is below 30°C.

