

# SERVICE MANUAL



Indoor unit	Outdoor unit
RCG36LRLA	ROG36LATT
RCG45LRLA	ROG45LATT
RCG54LRLA	ROG54LATT

## CONTENTS

SPECIFICATIONS . . . . .	1
DIMENSIONS . . . . .	2
REFRIGERANT SYSTEM DIAGRAM . . . .	4
CIRCUIT DIAGRAM . . . . .	5
INDOOR PCB CIRCUIT DIAGRAM . . . . .	6
OUTDOOR PCB CIRCUIT DIAGRAM . . .	10
ERROR DETECTION . . . . .	17
PARTS (DECORATION PANEL) . . . . .	21
PARTS (INDOOR UNIT) . . . . .	24
PARTS (OUTDOOR UNIT) . . . . .	28
ACCESSORIES . . . . .	31

# SPECIFICATIONS

## ELECTRICAL DATA

TYPE		Cooling & Heating		
INDOOR UNIT		RCG36LRLA	RCG45LRLA	RCG54LRLA
OUTDOOR UNIT		ROG36LATT	ROG45LATT	ROG54LATT
COOLING CAPACITY		10.0 kW	12.5 kW	14.0 kW
HEATING CAPACITY		11.2 kW	14.0 kW	16.0 kW
POWER SOURCE		400 V, 50 Hz, 3 phase, 4 W		
RUNNING CURRENT	Cooling	3.7 A	5.3 A	6.5 A
	Heating	3.9 A	5.3 A	6.6 A
INPUT WATTS	Cooling	2.44 kW	3.54 kW	4.36 kW
	Heating	2.56 kW	3.58 kW	4.43 kW
E.E.R.	Cooling	4.10 kW/kW	3.53 kW/kW	3.21 kW/kW
	Heating	4.38 kW/kW	3.91 kW/kW	3.61 kW/kW
MOISTURE REMOVAL		3.0 L/hr	4.5 L/hr	5.0 L/hr
AIRCIRCULATION INDOOR		1,800 m3/h	1,900 m3/h	2,000 m3/h
AIRCIRCULATION OUTDOOR	Cooling	6,200 m3/h	6,750 m3/h	6,900 m3/h
	Heating	6,200 m3/h	6,200 m3/h	6,900 m3/h
MAXIMUM CURRENT		7.9 A	8.9 A	9.9 A

## FAN MOTOR

INDOOR UNIT, Discrimination		MFF-54TVM		
INDOOR UNIT	High	660 r.p.m.	690 r.p.m.	720 r.p.m.
	Medium	540 r.p.m.	610 r.p.m.	630 r.p.m.
	Low	470 r.p.m.	550 r.p.m.	570 r.p.m.
	Quiet	430 r.p.m.	470 r.p.m.	480 r.p.m.
OUTDOOR UNIT, Discrimination		MFE-54VVT		
OUTDOOR UNIT Cooling	Upper fan	780 r.p.m.	850 r.p.m.	900 r.p.m.
	Lower fan	750 r.p.m.	800 r.p.m.	800 r.p.m.
OUTDOOR UNIT Heating	Upper fan	780 r.p.m.	780 r.p.m.	870 r.p.m.
	Lower fan	750 r.p.m.	750 r.p.m.	840 r.p.m.

## NOISE LEVEL

INDOOR UNIT	High	44 dB	46 dB	47 dB
	Medium	39 dB	42 dB	43 dB
	Low	36 dB	40 dB	41 dB
	Quiet	33 dB	36 dB	37 dB
OUTDOOR UNIT	Cooling	51 dB	54 dB	55 dB
	Heating	53 dB	54 dB	56 dB

## COMPRESSOR AND REFRIGERANT

TYPE		Hermetic type, Inverter, 4 poles, 3 phase, DC motor, Twin Rotary	
DISCRIMINATION		DA422A3F-29ZAD	
WEIGHT (with oil)		23.0 kg	
REFRIGERANT TYPE		R410A	
PRECHARGED REFRIGERANT		3,450 g	
MAX PIPE HEIGHT		30 m	
FULL CHARGE	Pipe length	30 m	3,450 g
		45 m	4,200 g
		60 m	4,950 g
		75 m	5,700 g
ADDITIONAL CHARGE		50 g/m	

## DIMENSIONS

DECORATION PANEL	H x W x D	50 x 950 x 950 mm
INDOOR UNIT	H x W x D	288 x 840 x 840 mm
OUTDOOR UNIT	H x W x D	1,290 x 900 x 330 mm

## WEIGHT

DECORATION PANEL	Shipping / Net	8.5 kg / 5.5 kg
INDOOR UNIT	Shipping / Net	31 kg / 27 kg
OUTDOOR UNIT	Shipping / Net	113 kg / 104 kg

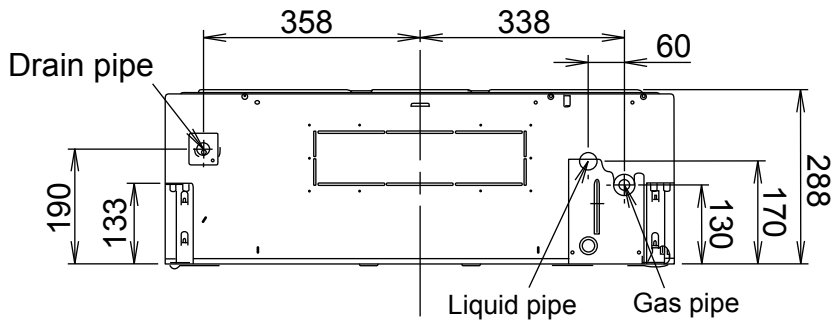

Side view

## DIMENSIONS

INDOOR UNIT  
DECORATION PANEL

(Unit : mm)

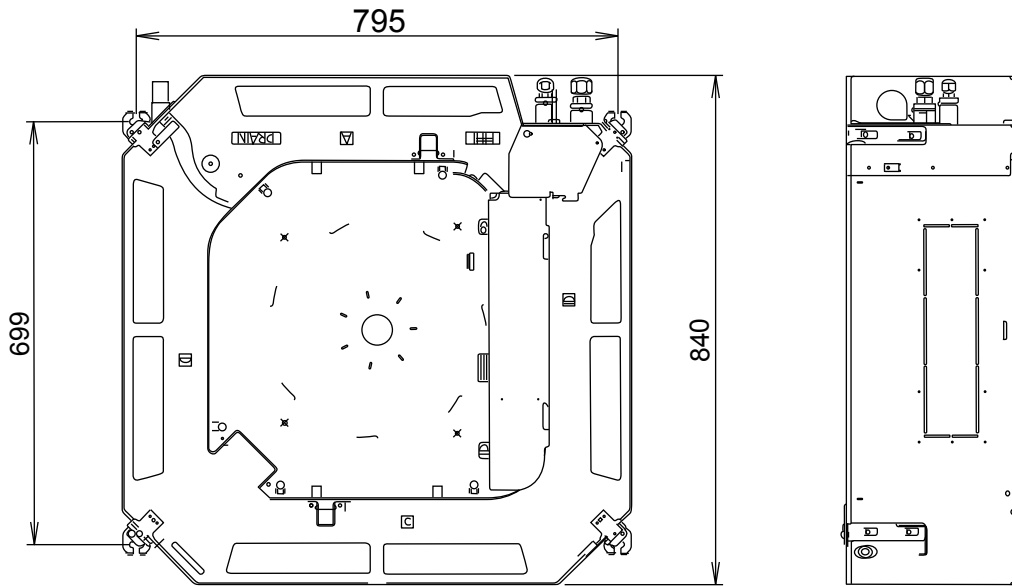

Bottom view

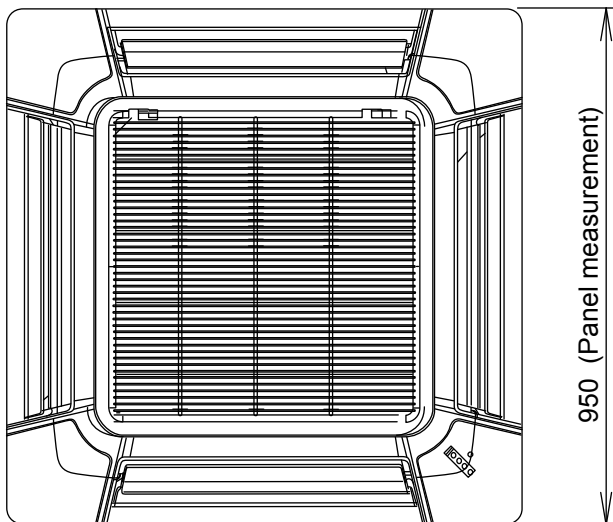

Bottom view

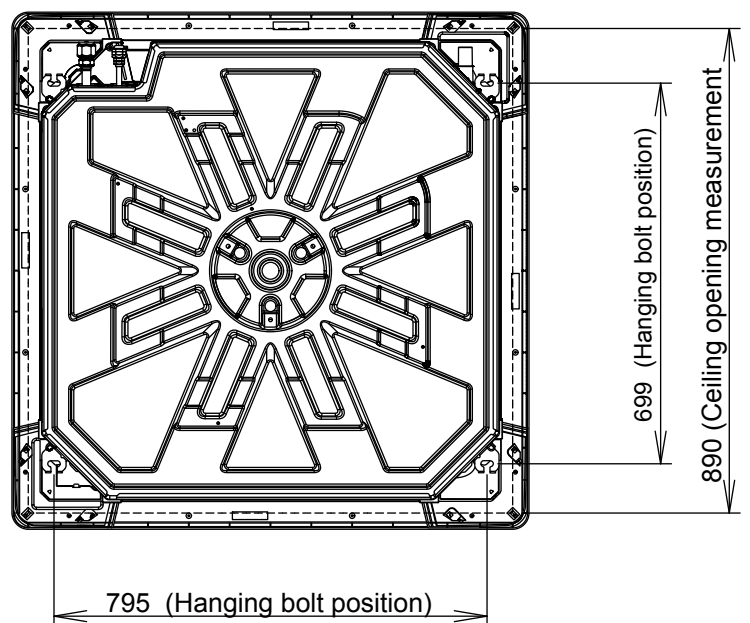

Top view

OUTDOOR UNIT  
(unit : mm)

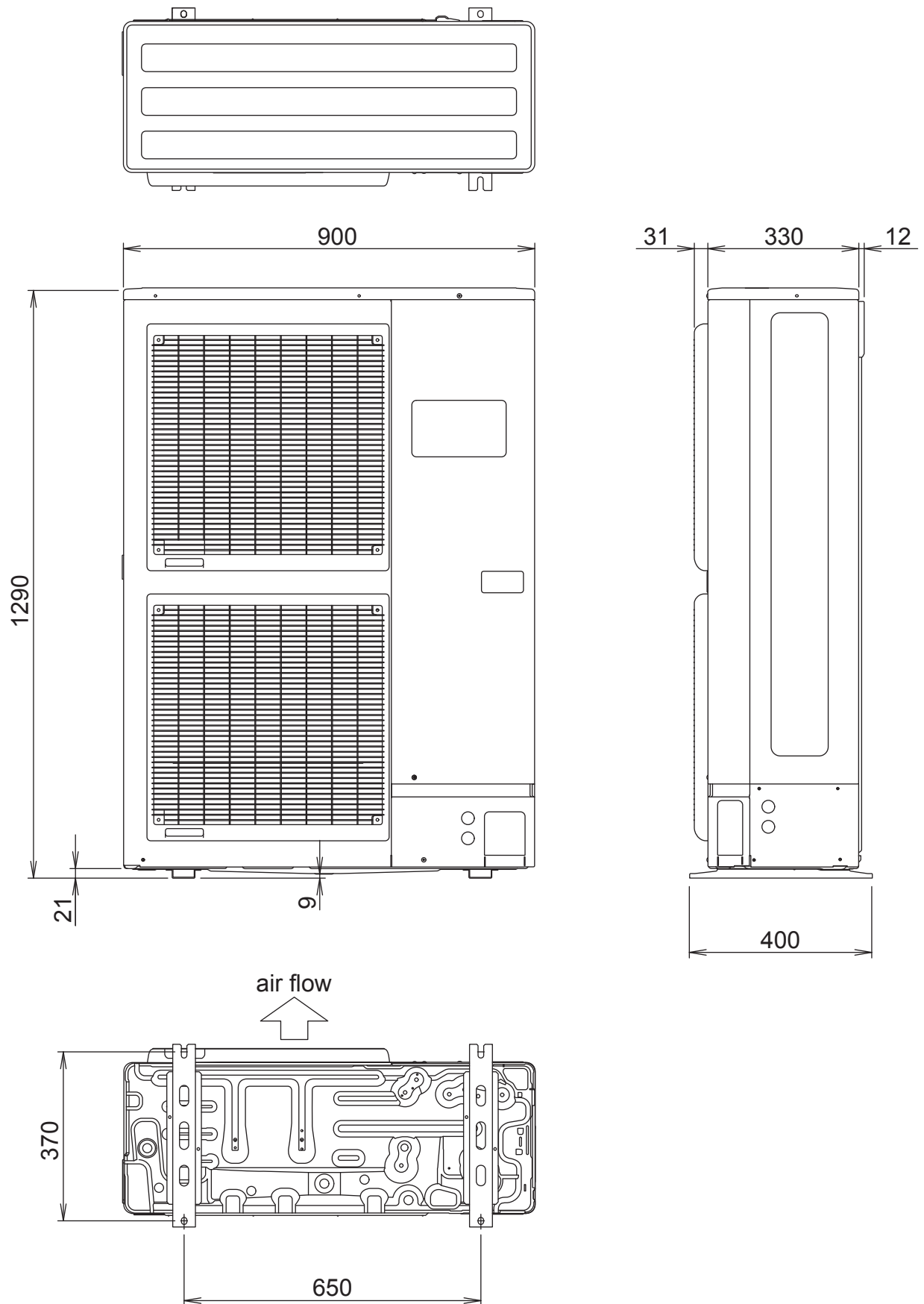



# CIRCUIT DIAGRAM

# OUTDOOR UNIT

## INDOOR UNIT

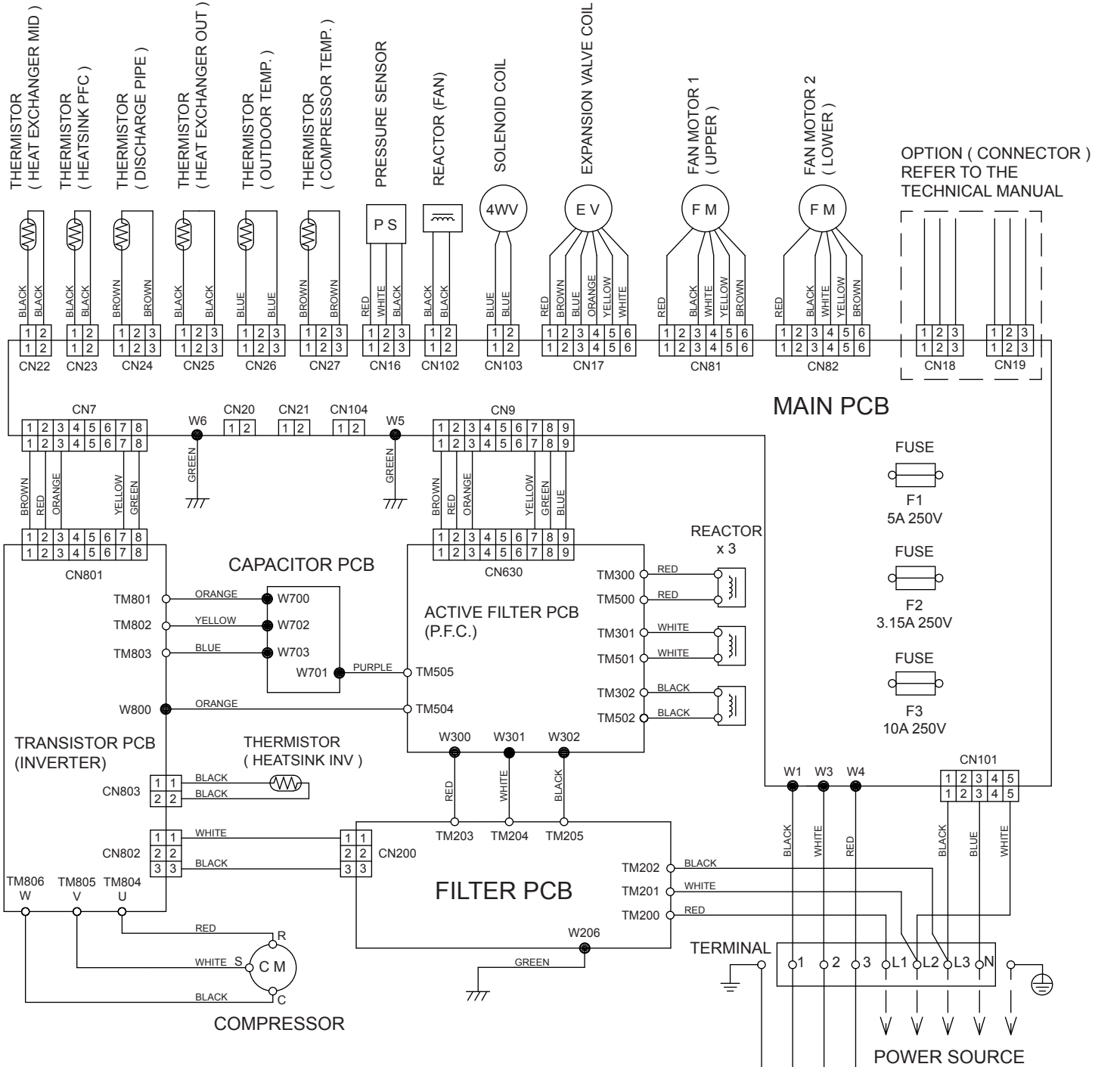
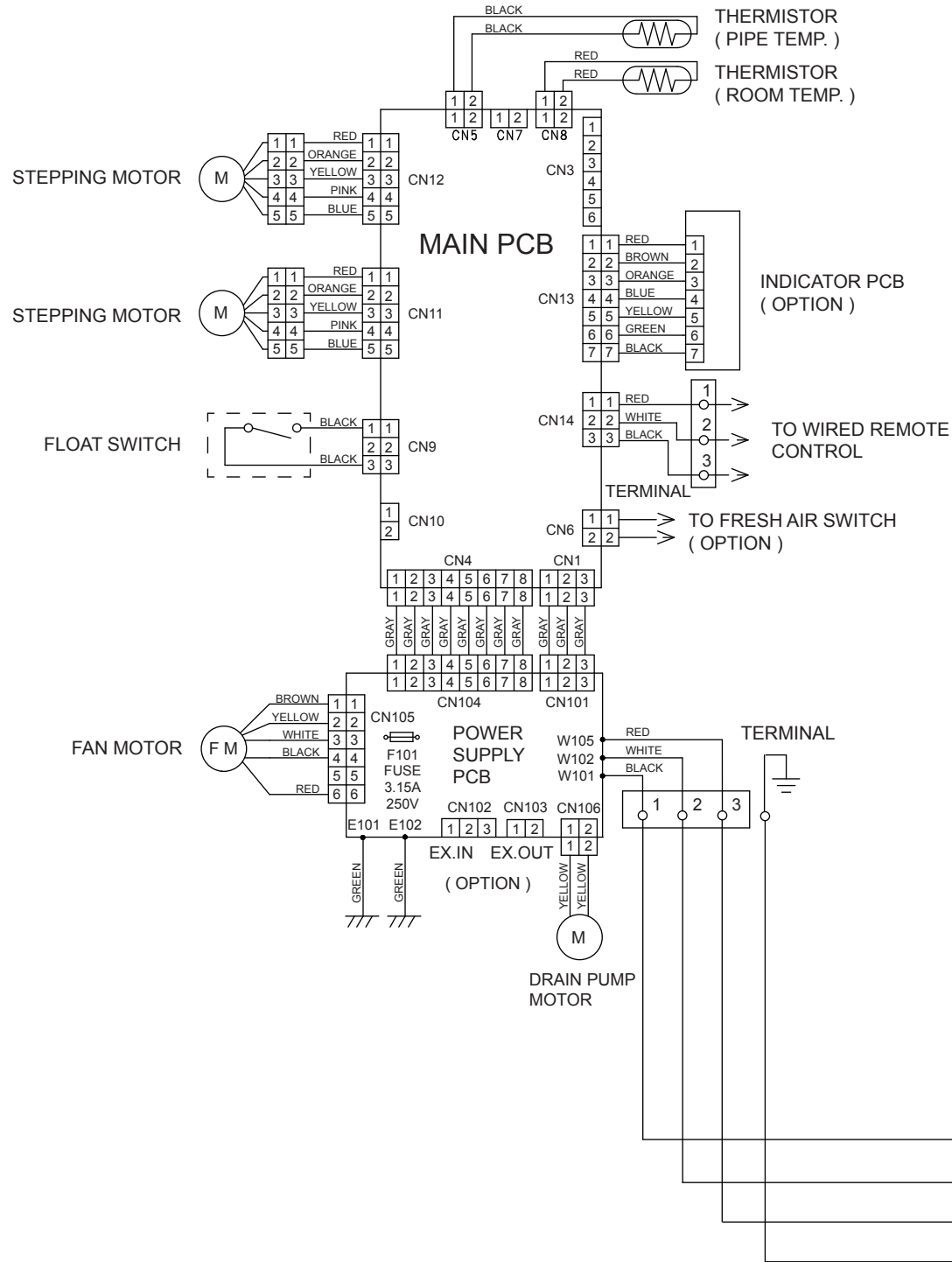

# INDOOR PCB CIRCUIT DIAGRAM

CONTROL UNIT  
 RCG36LRLA : EZ-0122PHSE  
 RCG45LRLA : EZ-0122RHSE  
 RCG54LRLA : EZ-0122SHSE

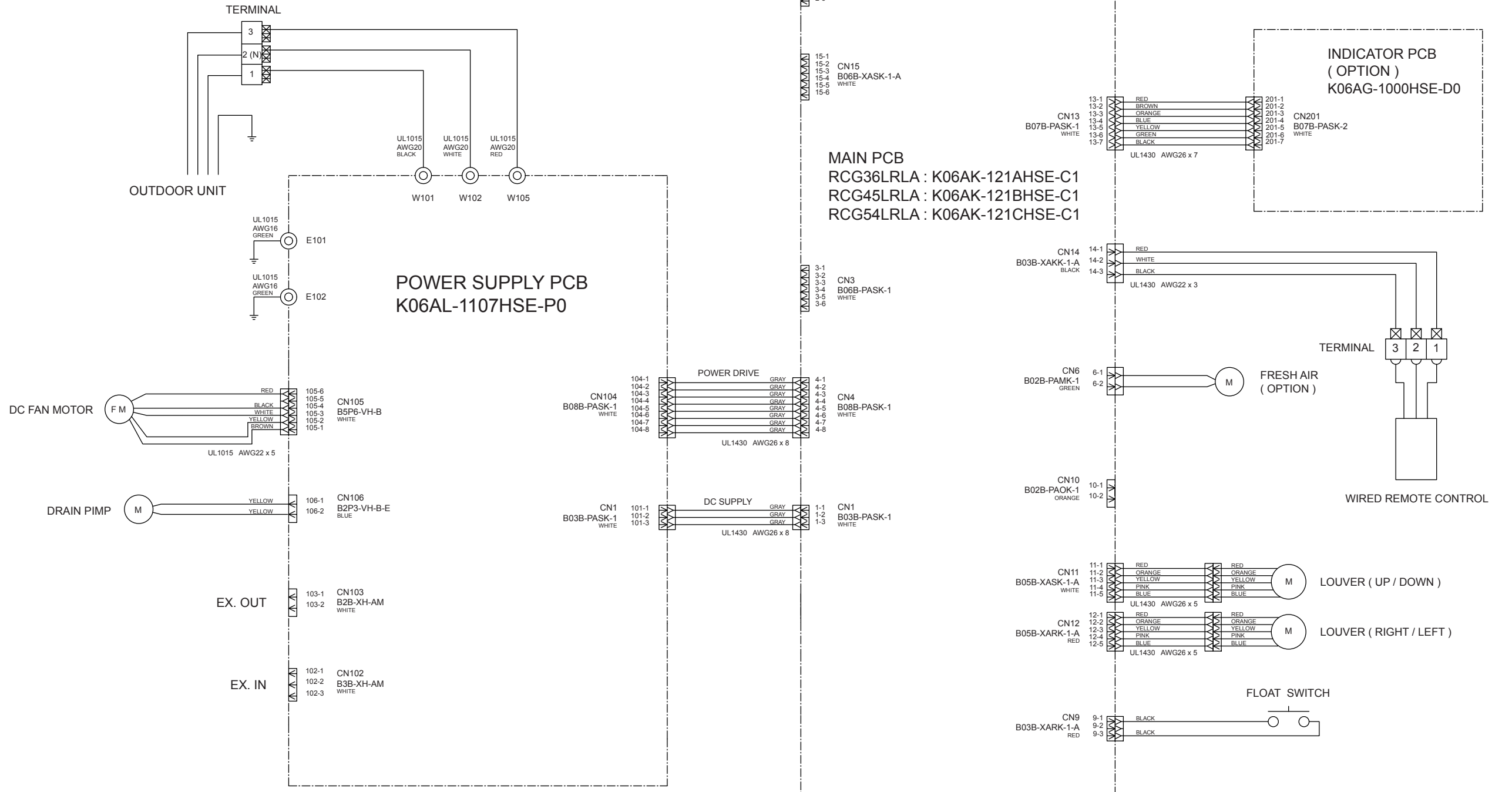

INDOOR UNIT

MAIN PCB

RCG36LRLA : K06AK-121AHSE-C1

RCG45LRLA : K06AK-121BHSE-C1

RCG54LRLA : K06AK-121CHSE-C1

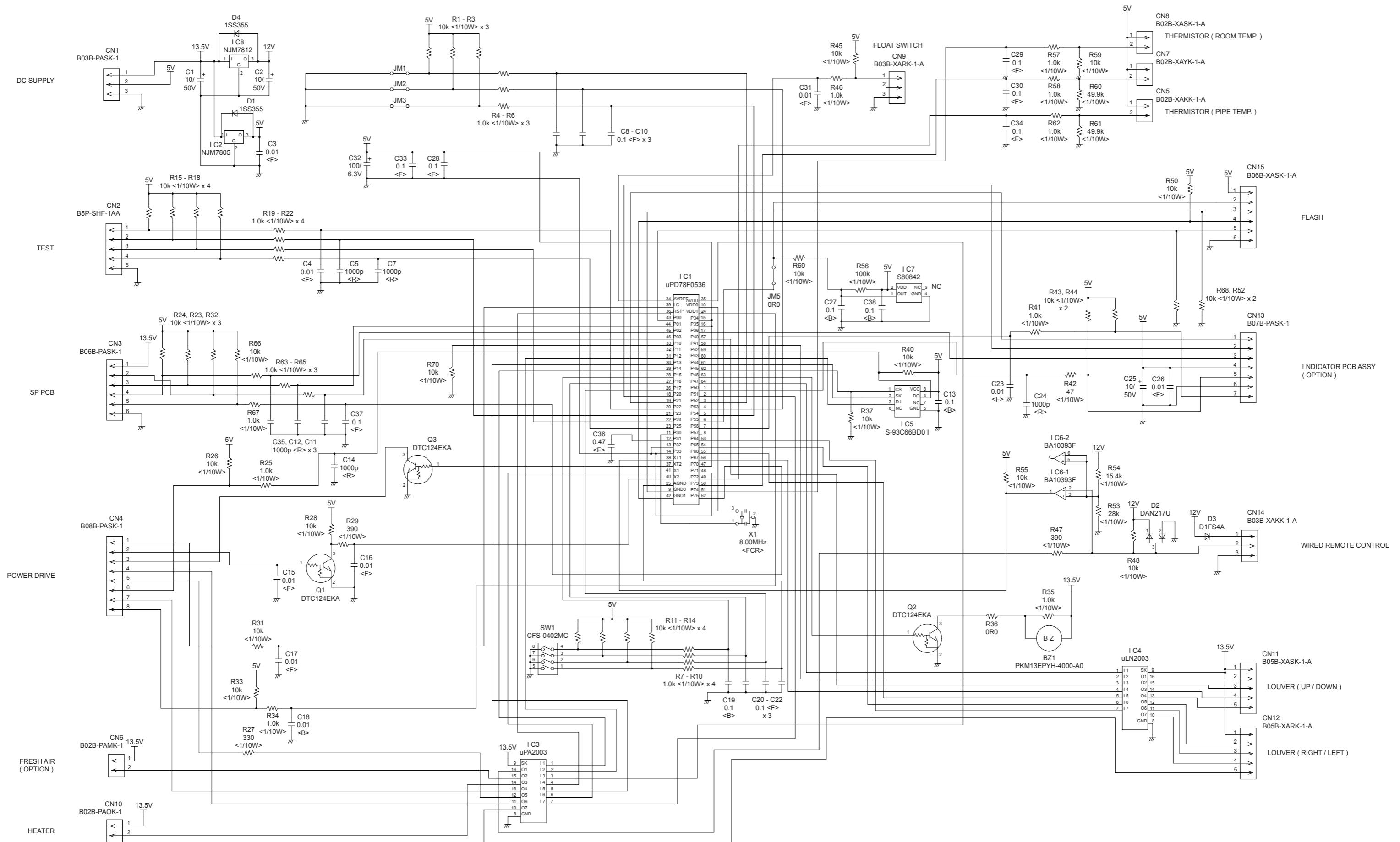



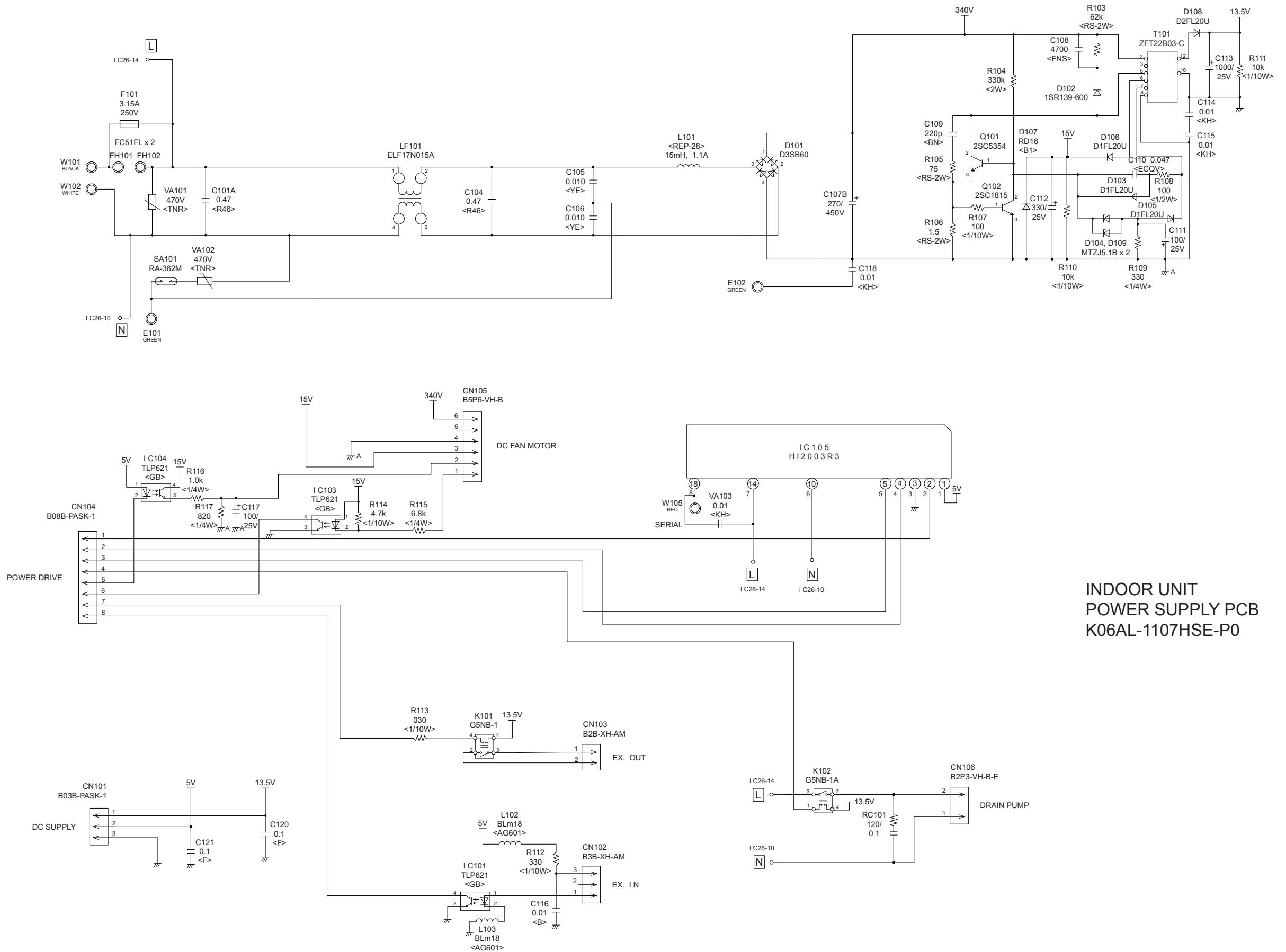

INDOOR UNIT  
POWER SUPPLY PCB  
K06AL-1107HSE-P0

INDOOR UNIT  
 INDICATOR PCB ( OPTION )  
 K06AG-1000HSE-D0

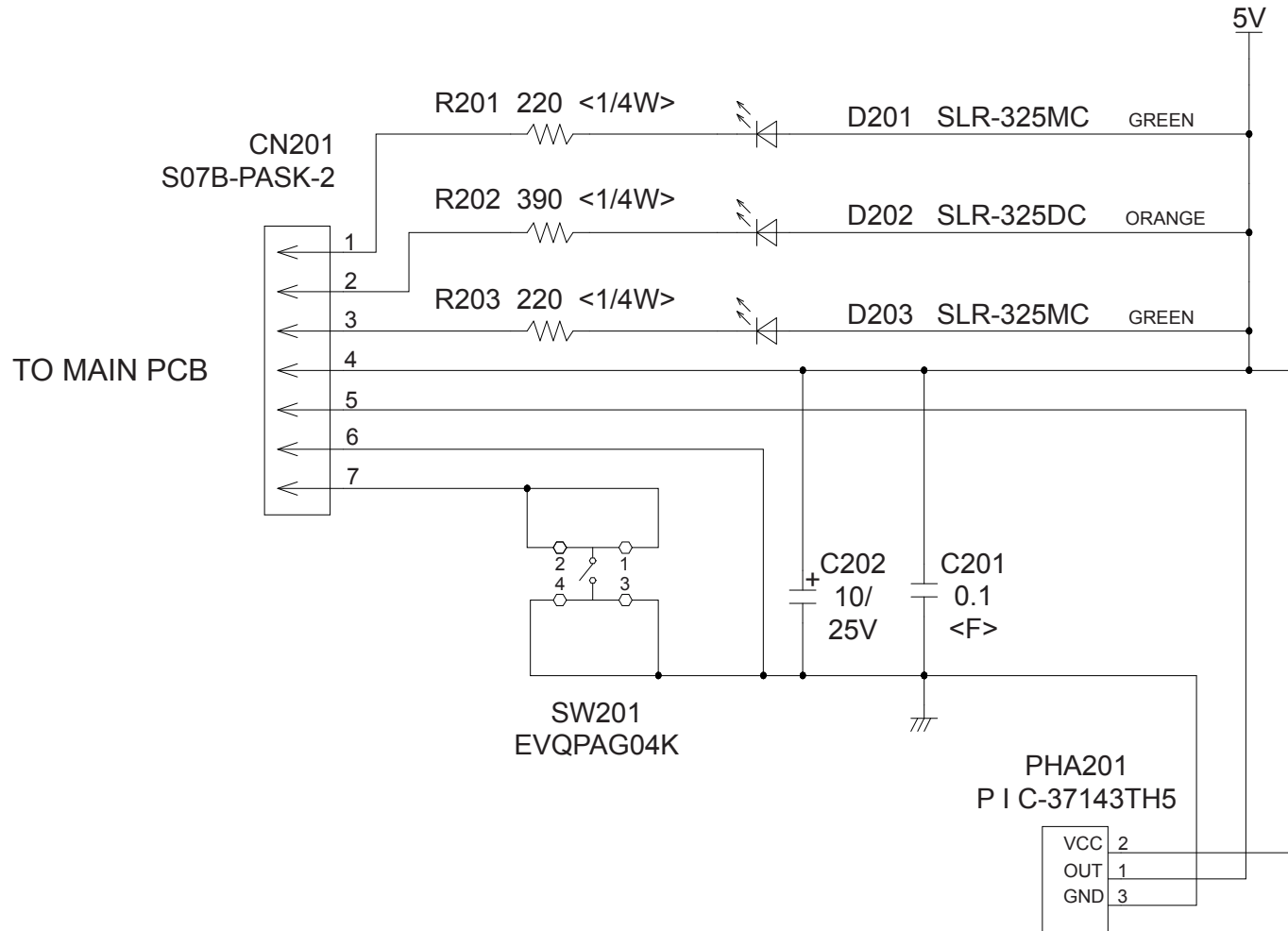

# OUTDOOR PCB CIRCUIT DIAGRAM

## INVERTER ASSEMBLY

ROG36LATT : EZ-01222HUE

ROG45LATT : EZ-0111WHUE

ROG54LATT : EZ-0111YHUE

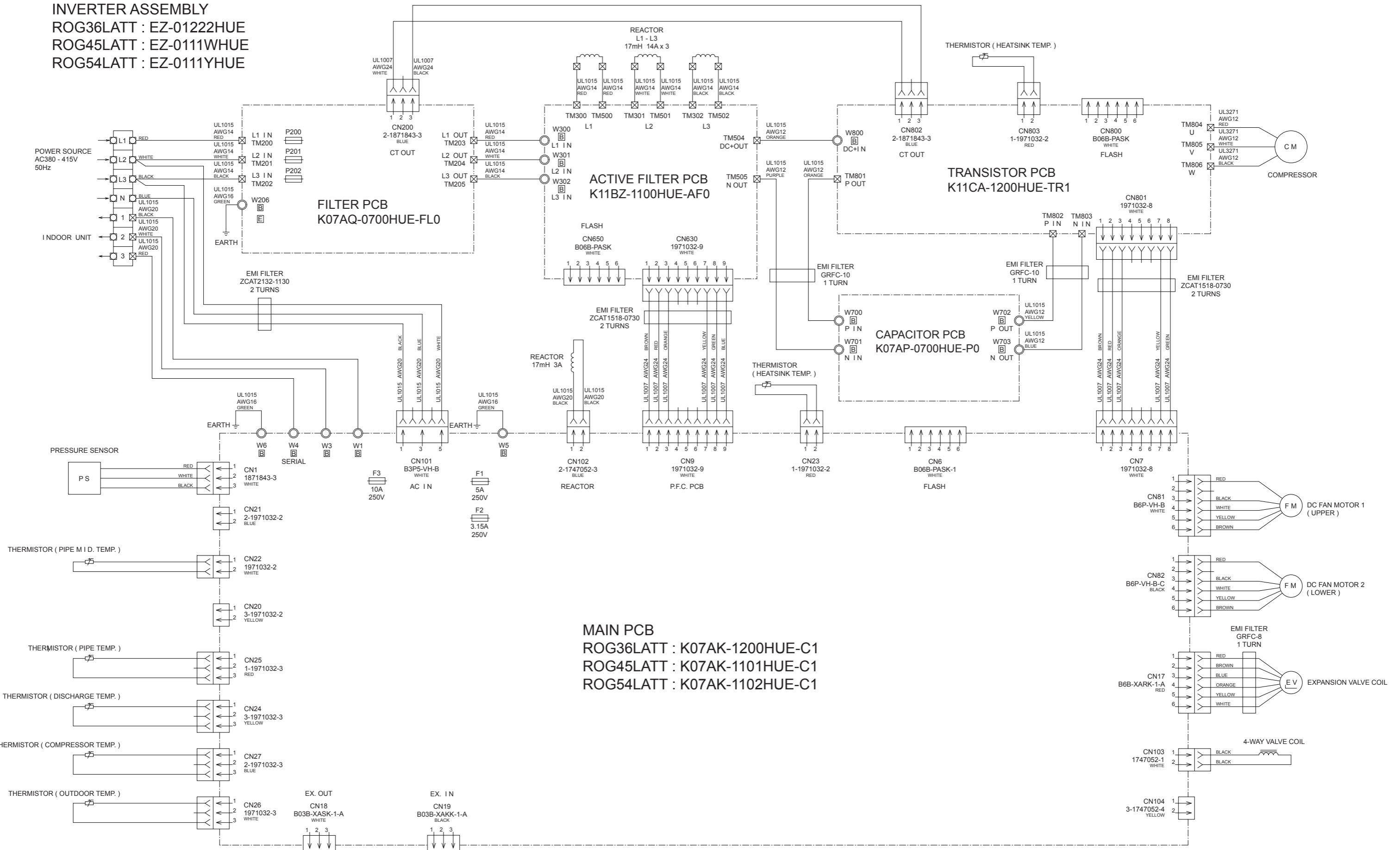

OUTDOOR UNIT  
 MAIN PCB  
 ROG36LATT : K07AK-1200HUE-C1  
 ROG45LATT : K07AK-1101HUE-C1  
 ROG54LATT : K07AK-1102HUE-C1

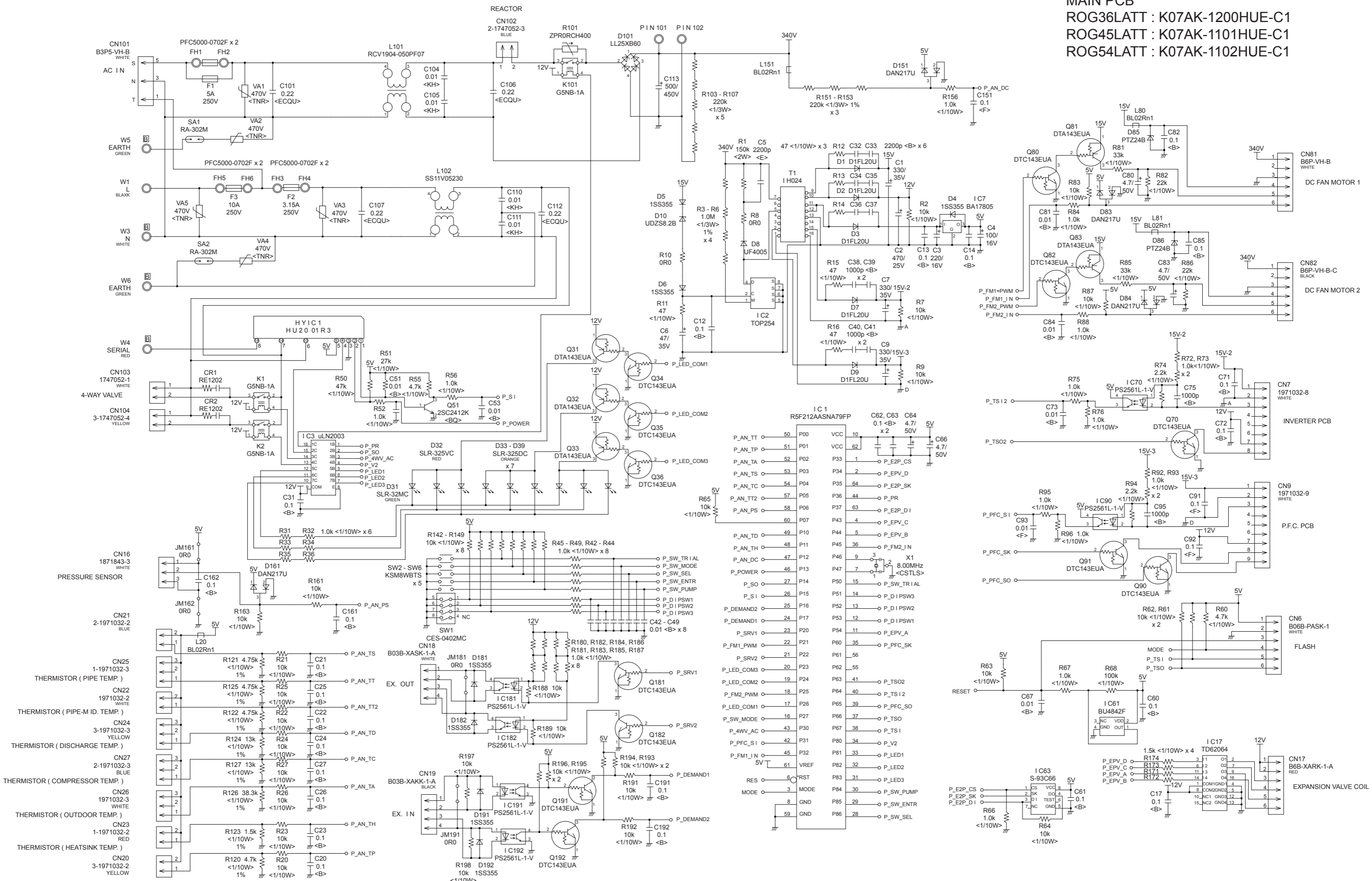

# OUTDOOR UNIT TRANSISTOR PCB K11CA-1200HUE-TR1

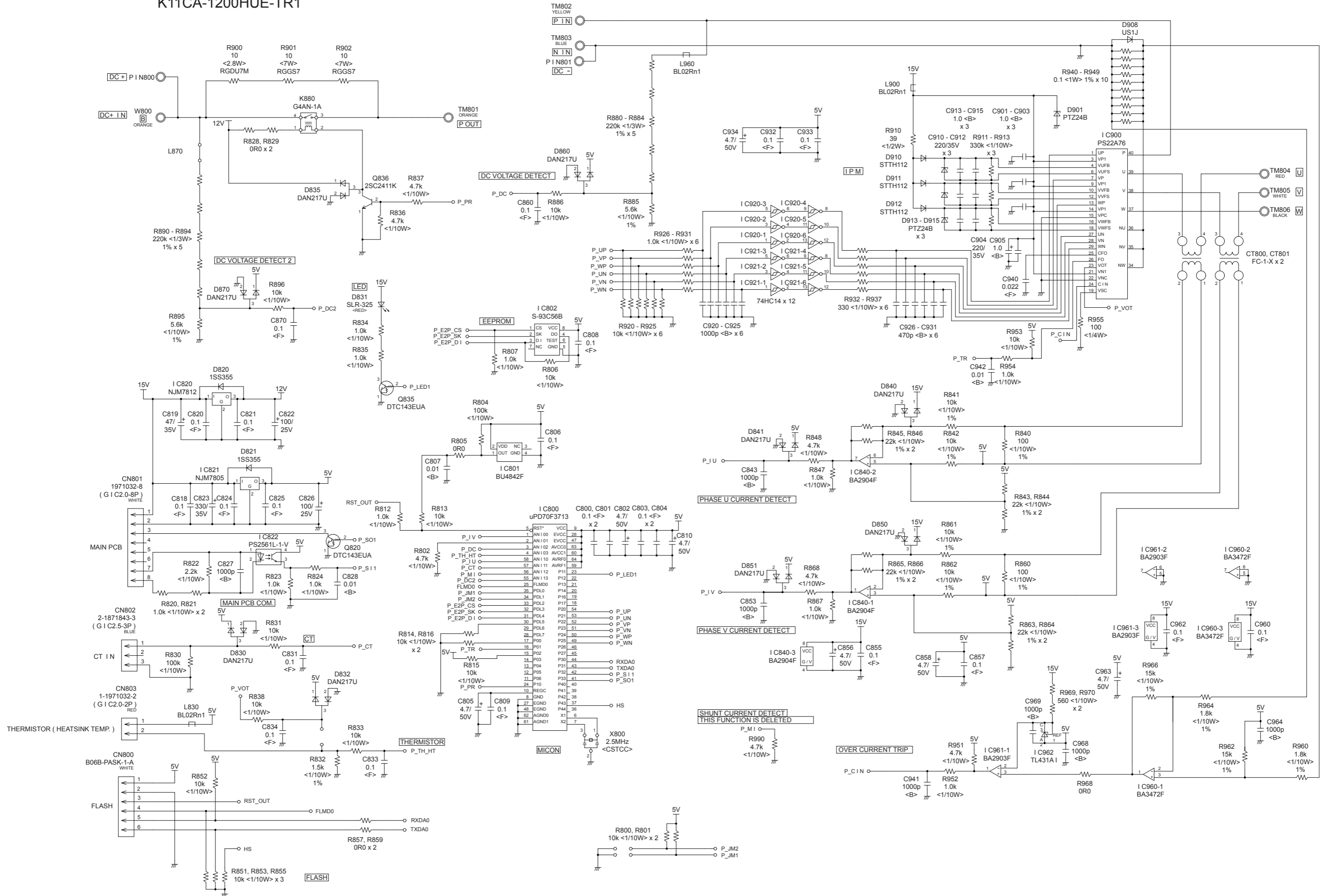

OUTDOOR UNIT  
ACTIVE FILTER PCB - 1  
K-11BZ-1100HUE-AF0

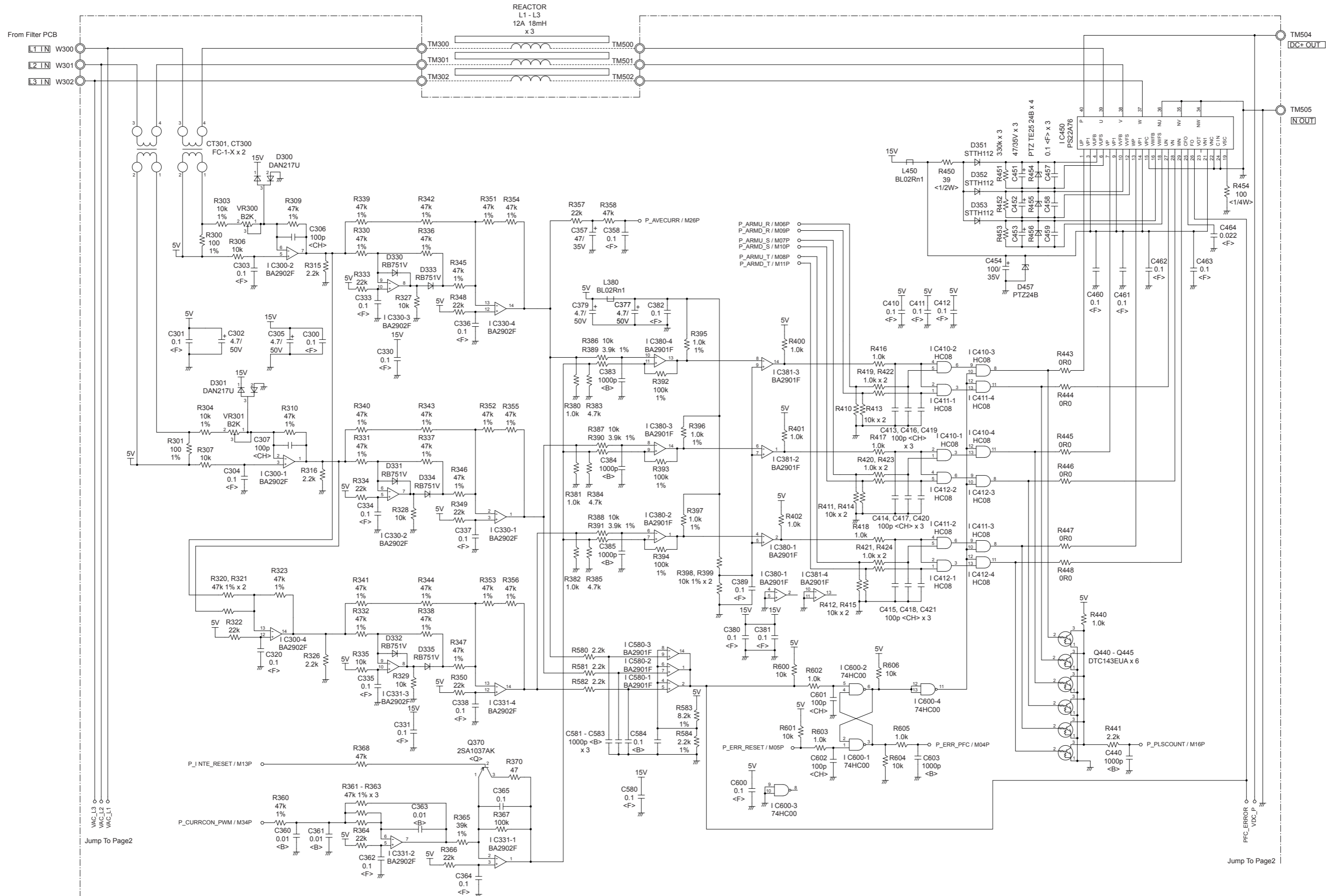

OUTDOOR UNIT  
ACTIVE FILTER PCB - 2  
K11BZ-1100HUE-AF0

Jump To Page1

Jump To Page1

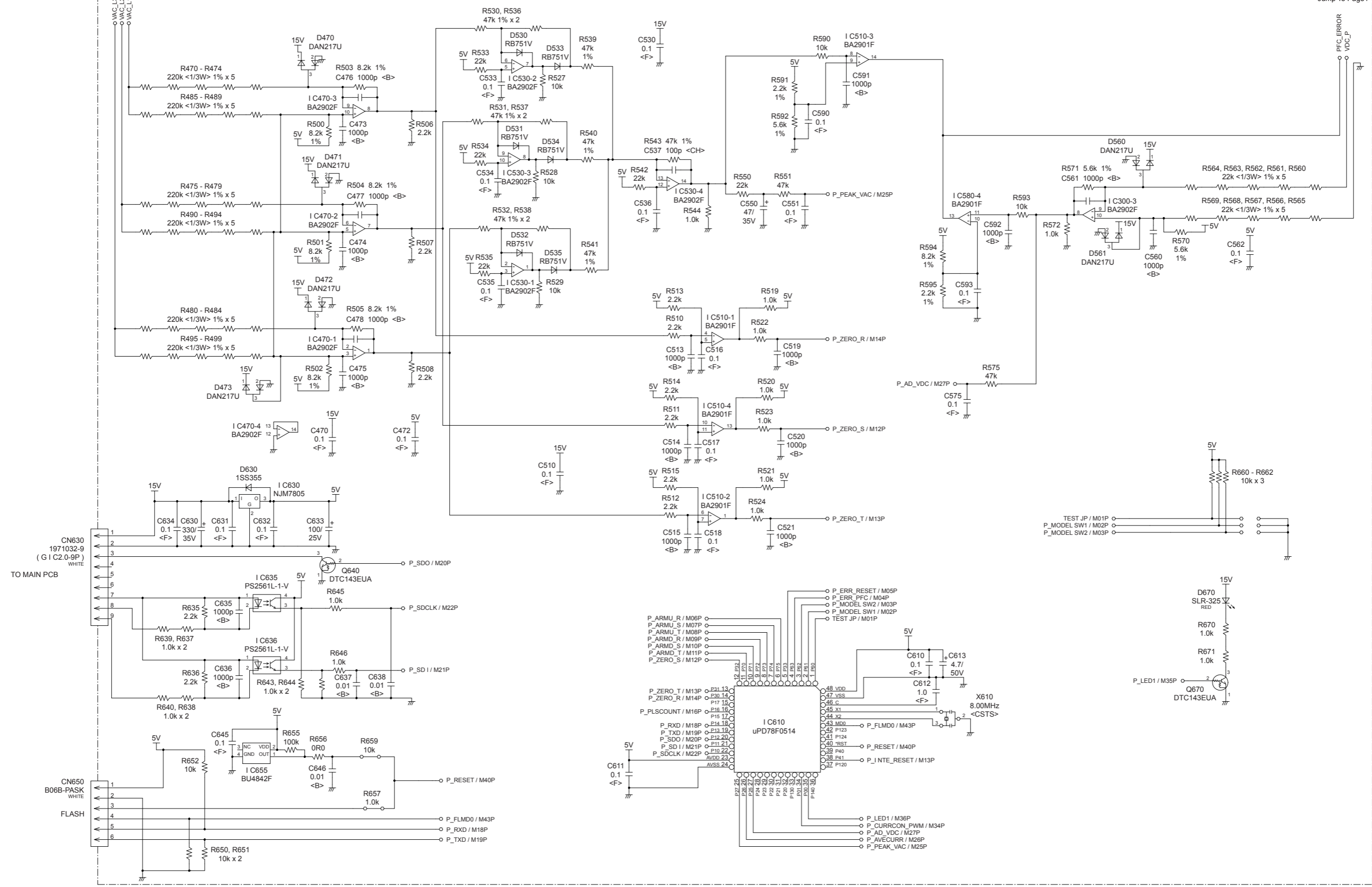

# OUTDOOR UNIT FILTER PCB K07AQ-0700HUE-FLO

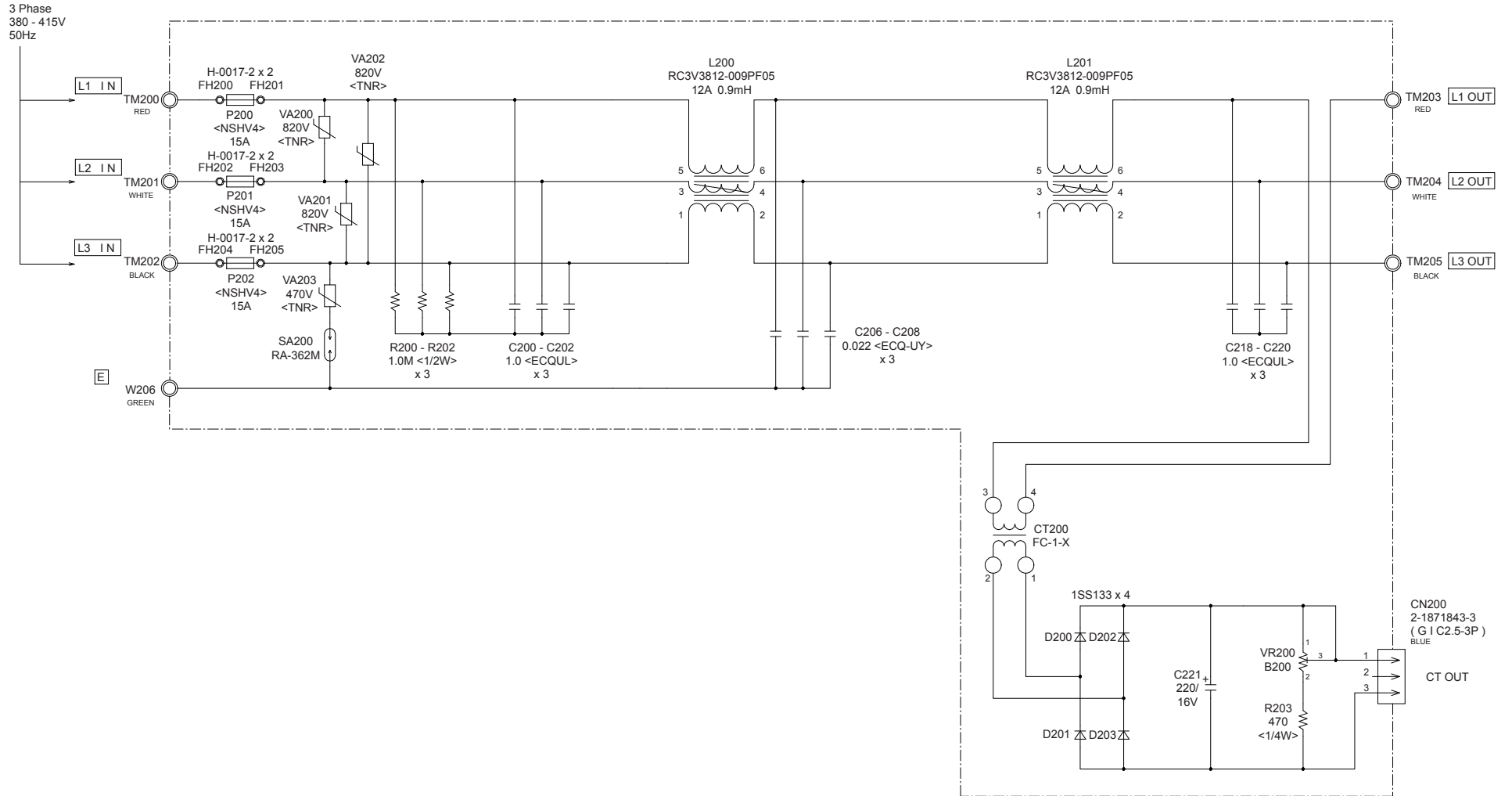



OUTDOOR UNIT  
CAPACITOR PCB  
K07AP-0700HUE-P0

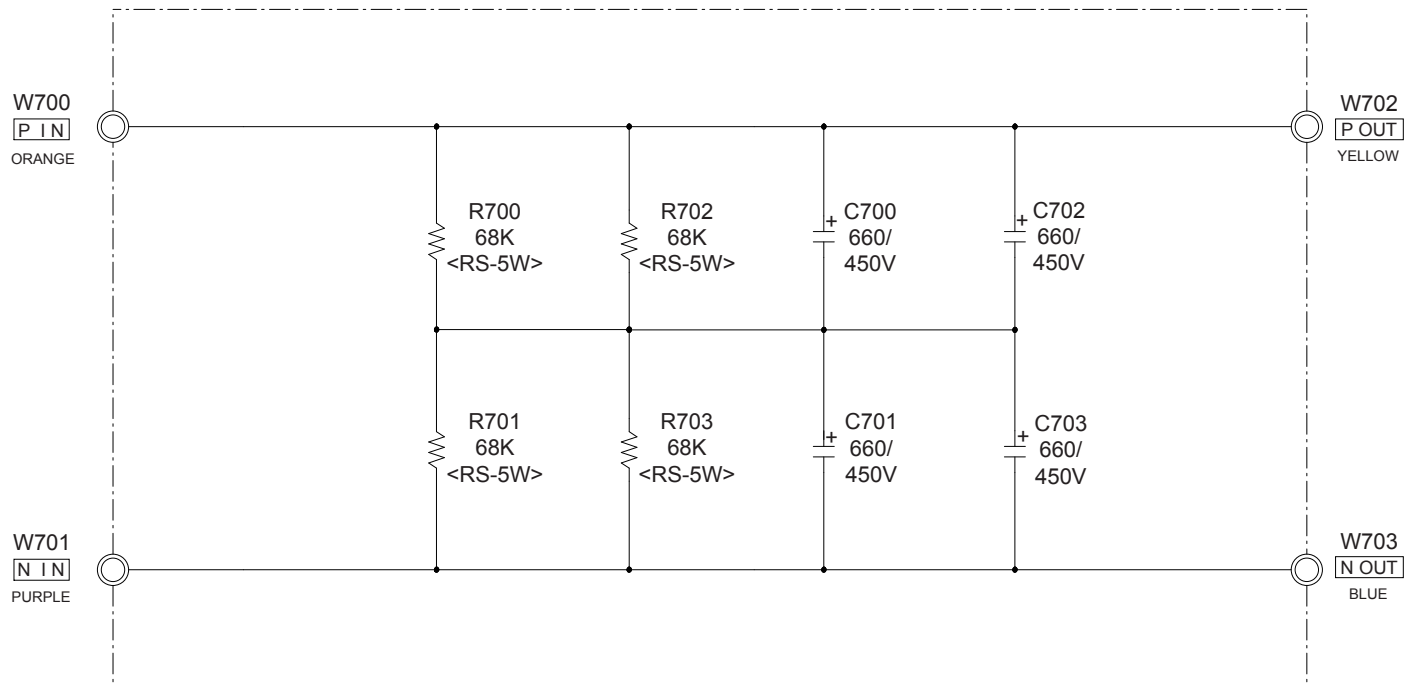

# ERROR DETECTION

## INDOOR UNIT and WIRED REMOTE CONTROL

If you use a wireless remote control, the lamp on the photo detector unit will output error codes by way of blinking patterns.

If you use a wired type remote control, error codes will appear on the remote control display. See the lamp blinking patterns and error codes in the table. An error display is displayed only during running.

### Remote control

This is possible only on a wired remote control.

If an error occurs, the following display will be shown. ("Er" will appear in the set room temperature display.)

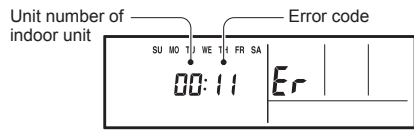

EX. Self-diagnosis

### Indoor unit display (option)

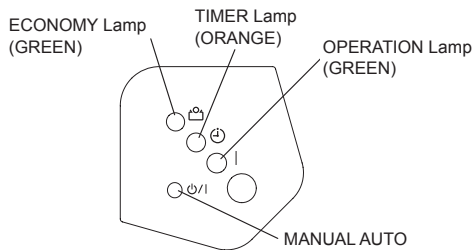

● : 0.5s on / 0.5s off

◇ : 0.1s on / 0.1s off

( ) : Number of flashing

Indoor unit			Wired remote control	Description
OPERATION lamp (green)	TIMER lamp (orange)	ECONOMY lamp (green)		
● (1)	● (1)	◇	11	Serial communication error
● (1)	● (2)	◇	12	Wired remote control communication error
● (1)	● (5)	◇	15	Check run unfinished
● (2)	● (1)	◇	21	Unit number or Refrigerant circuit address setting error [Simultaneous Multi]
● (2)	● (2)	◇	22	Indoor unit capacity error
● (2)	● (3)	◇	23	Combination error
● (2)	● (4)	◇	24	• Connection unit number error (indoor slave unit) [Simultaneous Multi] • Connection unit number error (indoor unit or branch unit) [Flexible Multi]
● (2)	● (7)	◇	27	Master unit, slave unit set-up error [Simultaneous Multi]
● (3)	● (1)	◇	31	Power supply interruption error
● (3)	● (2)	◇	32	Indoor unit PCB model information error
● (3)	● (5)	◇	35	Manual auto switch error
● (4)	● (1)	◇	41	Inlet air temp. sensor error
● (4)	● (2)	◇	42	Indoor unit Heat Ex. Middle temp. sensor error
● (5)	● (1)	◇	51	Indoor unit fan motor error
● (5)	● (3)	◇	53	Drain pump error
● (5)	● (7)	◇	57	Damper error
● (5)	● (15)	◇	5U	Indoor unit error
● (6)	● (2)	◇	62	Outdoor unit main PCB model information error or communication error
● (6)	● (3)	◇	63	Inverter error
● (6)	● (4)	◇	64	Active filter error, PFC circuit error
● (6)	● (5)	◇	65	Trip terminal LError
● (6)	● (10)	◇	6A	Display PCB microcomputers communication error

Indoor unit			Wired remote control	Description
OPERATION lamp (green)	TIMER lamp (orange)	ECONOMY lamp (green)		
● (7)	● (1)	◇	71	Discharge temp. sensor error
● (7)	● (2)	◇	72	Compressor temp. sensor error
● (7)	● (3)	◇	73	Outdoor unit Heat Ex. liquid temp. sensor error
● (7)	● (4)	◇	74	Outdoor temp. sensor error
● (7)	● (5)	◇	75	Suction Gas temp. sensor error
● (7)	● (6)	◇	76	• 2-way valve temp. sensor error • 3-way valve temp. sensor error
● (7)	● (7)	◇	77	Heat sink temp. sensor error
● (8)	● (2)	◇	82	• Sub-cool Heat Ex. gas inlet temp. sensor error • Sub-cool Heat Ex. gas outlet temp. sensor error
● (8)	● (3)	◇	83	Liquid pipe temp. sensor error
● (8)	● (4)	◇	84	Current sensor error
● (8)	● (6)	◇	86	• Discharge pressure sensor error • Suction pressure sensor error • High pressure switch error
● (9)	● (4)	◇	94	Trip detection
● (9)	● (5)	◇	95	Compressor rotor position detection error (permanent stop)
● (9)	● (7)	◇	97	Outdoor unit fan motor error
● (9)	● (8)	◇	98	Outdoor unit fan motor 2 error
● (9)	● (9)	◇	99	4-way valve error
● (9)	● (10)	◇	9A	Coil (expansion valve) error
● (10)	● (1)	◇	A1	Discharge temp. error
● (10)	● (3)	◇	A3	Compressor temp. error
● (10)	● (4)	◇	A4	High pressure error
● (10)	● (5)	◇	A5	Low pressure error
● (13)	● (2)	◇	J2	Branch boxes error [Flexible Multi]

# OUTDOOR UNIT

## TEST RUN

### ⚠ CAUTION

Always turn on the power 6 hours prior to the start of the operation in order to protect the compressor.

## 1. Check items before performing the test run

Make sure to perform the test run.

Before performing the test run, be sure to check the following points.

- (1) Is gas leaking?  
Check connection of each pipe (flare connection part, brazing part).
- (2) Is a breaker installed to the power cable of the outdoor unit ?
- (3) Has each cable been securely connected to the terminal according to the specifications ?
- (4) Are the 3-way valves (gas pipes and liquid pipes) of the outdoor units open?
- (5) Has the power been supplied to the unit for at least 6 hours ?
- (6) Has the necessary local setting been done ?
- (7) Check insulation resistance of 1 MΩ or more using a 500V mega tester.

If no problems are found with the above items, perform the test run according to "Test run method".

If any problems are found, immediately resolve the problem and re-check the items.

## 2. Test run method

### ⚠ CAUTION

If the test run is performed for 1 outdoor unit in a group control system installation, the test run will also be performed for the other units. Therefore, make sure that all of the units have been installed before starting a test run.  
(Group control system installation described in "SPECIAL INSTALLATION METHODS" in the installation manual of the indoor unit.)

Operate [ENTER] (TEST RUN) switch on the display board by the following procedure.

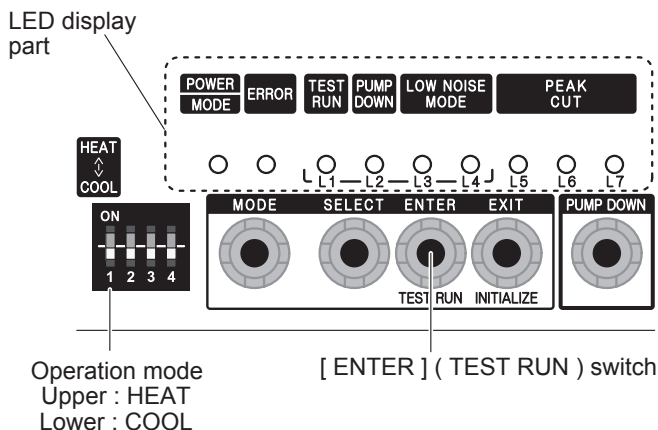

## 2.1. Operating procedures for the test run

- (1) Check the 3-way valves (both at the liquid side and gas side) are opened.
- (2) Set the operation mode to "COOL" or "HEAT".

POWER MODE	ERROR	TEST RUN (L1)	PUMP DOWN (L2)	LOW NOISE (L3) (L4)		PEAK CUT (L5) (L6) (L7)		
●	○	○	○	○	○	○	○	○

In the first test run, be sure to set the operation mode to "COOL".

The operation mode cannot be switched between "COOL" and "HEAT" during the test run. To switch the operation mode between "COOL" and "HEAT", stop the test run, switch the operation mode, and then start the test run again.

- (3) Press [ENTER] (TEST RUN) switch for more than 3 seconds.

POWER MODE	ERROR	TEST RUN (L1)	PUMP DOWN (L2)	LOW NOISE (L3) (L4)		PEAK CUT (L5) (L6) (L7)		
●	○	●	○	○	○	○	○	○

"TEST RUN" LED will light on.

If the compressor is operating at starting the test run, the compressor will stop and, after a while, the test run will start.

Either of the above "LOW NOISE" or "PEAK CUT" will light on during the test run if local setting function is selected.

- (4) Confirm operating status.
- (5) Press [ENTER] (TEST RUN) switch again.

POWER MODE	ERROR	TEST RUN (L1)	PUMP DOWN (L2)	LOW NOISE (L3) (L4)		PEAK CUT (L5) (L6) (L7)		
●	○	○	○	○	○	○	○	○

"TEST RUN" LED lights off, and TEST RUN stops.

Test run will finish after about 60 minutes automatically. At the same time, "TEST RUN" LED will light off.

Test run may be stopped before operating for 60 minutes if an error occurs after a starting test run.

# OUTDOOR UNIT ERROR CODE DISPLAY

Display when an error occurs

POWER MODE	ERROR	TEST RUN (L1)	PUMP DOWN (L2)	LOW NOISE (L3) (L4)		PEAK CUT (L5) (L6) (L7)		
●	Blinks (Hi-speed)	○	○	○	○	○	○	○

Check that the ERROR LED blinks,  
and then short-press the [ENTER] switch once.  
The number of blinks of the LED indicates the type of error.

Display mode ● : ON  
○ : OFF  
◆ : Blink (0.5s ON / 0.5s OFF)  
( ) : Number of flashing

## Error code check table

POWER MODE	ERROR	TEST RUN (L1)	PUMP DOWN (L2)	LOW NOISE		PEAK CUT			Description
				(L3)	(L4)	(L5)	(L6)	(L7)	
◆(2)	●	◆(1)	◆(1)	○	○	○	●	●	Serial forward transmission error immediately after operation
◆(2)	●	◆(1)	◆(1)	○	○	●	○	○	Serial forward transmission error during operation
◆(2)	●	◆(2)	◆(2)	○	○	○	○	●	Indoor unit capacity error
◆(2)	●	◆(5)	◆(15)	○	○	○	○	●	Indoor unit error
◆(2)	●	◆(6)	◆(1)	○	○	○	○	●	Over voltage
◆(2)	●	◆(6)	◆(1)	○	○	○	●	●	Power supply frequency error
◆(2)	●	◆(6)	◆(2)	○	○	○	○	●	Outdoor unit PCB model information error
◆(2)	●	◆(6)	◆(2)	○	○	●	●	●	PFC communication error
◆(2)	●	◆(6)	◆(3)	○	○	○	○	●	Inverter error
◆(2)	●	◆(6)	◆(4)	○	○	●	●	●	PFC AD detection error
◆(2)	●	◆(6)	◆(4)	○	●	○	○	○	PFC hardware error
◆(2)	●	◆(6)	◆(5)	○	○	○	●	●	IPM error (Trip terminal L error)
◆(2)	●	◆(6)	◆(8)	○	○	○	●	○	Rush current limiting resistor temp rise protection
◆(2)	●	◆(7)	◆(1)	○	○	○	○	●	Discharge temp. sensor error
◆(2)	●	◆(7)	◆(2)	○	○	○	○	●	Compressor temp. sensor error
◆(2)	●	◆(7)	◆(3)	○	○	○	●	○	Heat Ex. middle temp. sensor error
◆(2)	●	◆(7)	◆(3)	○	○	○	●	●	Outdoor unit Heat Ex. liquid temp. sensor error
◆(2)	●	◆(7)	◆(4)	○	○	○	○	●	Outdoor temp. sensor error
◆(2)	●	◆(7)	◆(7)	○	○	○	○	●	Heat sink temp. sensor error
◆(2)	●	◆(7)	◆(7)	○	○	○	●	○	PFC heat sink temp. sensor error
◆(2)	●	◆(8)	◆(4)	○	○	○	○	●	Current sensor 1 error (stoppage permanently)
◆(2)	●	◆(8)	◆(6)	○	○	●	○	○	High pressure switch 1 error
◆(2)	●	◆(8)	◆(6)	○	○	●	●	○	Pressure sensor error
◆(2)	●	◆(9)	◆(4)	○	○	○	○	●	Trip detection (stoppage permanently)
◆(2)	●	◆(9)	◆(5)	○	○	○	○	●	Compressor motor control error (stoppage permanently)
◆(2)	●	◆(9)	◆(5)	○	○	●	○	●	Compressor motor loss of synchronization (stoppage permanently)
◆(2)	●	◆(9)	◆(7)	○	○	○	●	●	Outdoor unit fan motor 1 error (Duty error)
◆(2)	●	◆(9)	◆(8)	○	○	○	●	●	Outdoor unit fan motor 2 error (Duty error)
◆(2)	●	◆(9)	◆(9)	○	○	○	○	●	4-way valve error
◆(2)	●	◆(10)	◆(1)	○	○	○	○	●	Discharge temp. 1 error (stoppage permanently)
◆(2)	●	◆(10)	◆(3)	○	○	○	○	●	Compressor 1 temp. error (stoppage permanently)
◆(2)	●	◆(10)	◆(5)	○	○	○	○	●	Low pressure error

# OUTDOOR UNIT

## PUMP DOWN (Refrigerant collecting operation)

Perform the following procedures to collect the refrigerant when moving the indoor unit or outdoor unit

**WARNING**  
Never touch electrical components such as the terminal blocks or reactor except the switch on the display board. It may cause a serious accident such as electric shock.

**CAUTION**  
Perform the pump down operation before disconnecting any refrigerant pipe or electric cable.

Collect refrigerant from the service port or the 3-way valve if pump down cannot be performed.

In case of a group control system installation, do not turn the power off pump down is completed in all outdoor units.  
(Group control system installation described in "SPECIAL INSTALLATION METHODS" in the installation manual of the indoor unit.)

Operate [PUMP DOWN] switch on the display board in the manner described below.

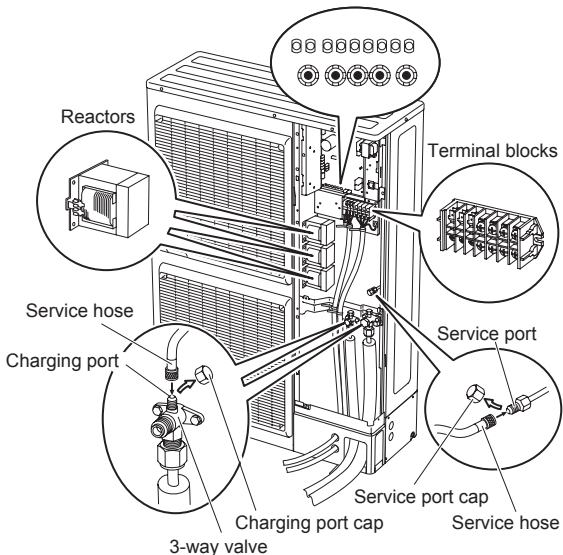
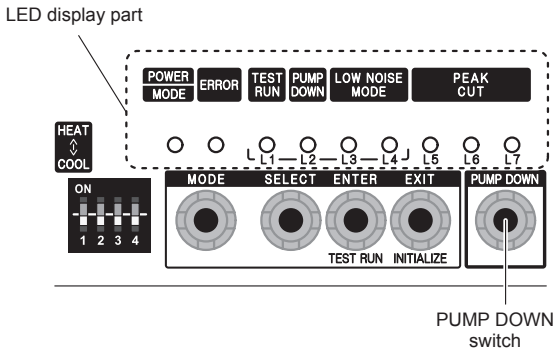

### 1. Preparation for pump down

Confirm that the power is off, and then open the service panel.

### 2. Pump down procedure

- (1) Check the 3-way valves (both at the liquid side and gas side) are opened.
- (2) Turn the power on.

POWER	ERROR	TEST RUN (L1)	PUMP DOWN (L2)	LOW NOISE (L3)	(L4)	PEAK CUT (L5) (L6) (L7)		
●	○	○	○	○	○	○	○	○

- (3) Press [PUMP DOWN] switch for 3 seconds or more after 3 minutes after power on.

POWER	ERROR	TEST RUN (L1)	PUMP DOWN (L2)	LOW NOISE (L3)	(L4)	PEAK CUT (L5) (L6) (L7)		
●	○	○	●	○	○	●	●	●

LED display lights on as shown in the above figure, and the fans and the compressor start operating.

If the [PUMP DOWN] switch is pressed while the compressor is operating, the compressor will stop, then start again in about 3 minutes.

- (4) LED display will change as shown below about 3 minutes after the compressor starts. Fully close the 3-way valve on the liquid pipe side at this stage.

POWER	ERROR	TEST RUN (L1)	PUMP DOWN (L2)	LOW NOISE (L3)	(L4)	PEAK CUT (L5) (L6) (L7)		
●	○	○	●	○	○	○	●	●

If the valve on the liquid pipe side is not closed, the pump down cannot be performed.

- (5) When LED display changes as shown in the below figure, close the 3-way valve on the gas pipe side tightly.

POWER	ERROR	TEST RUN (L1)	PUMP DOWN (L2)	LOW NOISE (L3)	(L4)	PEAK CUT (L5) (L6) (L7)		
●	○	○	●	○	○	○	○	●

If the valve on the gas pipe side is not closed, refrigerant may flow into the piping after the compressor stops

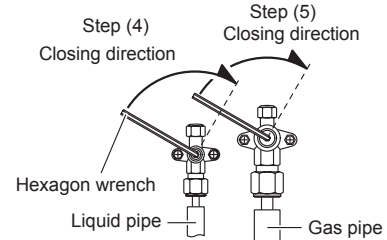

- (6) LED display changes after 1 minute as shown in the figure below

POWER	ERROR	TEST RUN (L1)	PUMP DOWN (L2)	LOW NOISE (L3)	(L4)	PEAK CUT (L5) (L6) (L7)		
●	○	○	●	○	○	○	○	○

Fans and compressor stop automatically.

If the pump down is successfully completed (the above LED display is shown), the outdoor unit remains stopped until the power is turned off.

- (7) Turn the power off.

POWER	ERROR	TEST RUN (L1)	PUMP DOWN (L2)	LOW NOISE (L3)	(L4)	PEAK CUT (L5) (L6) (L7)		
○	○	○	○	○	○	○	○	○

PUMP DOWN is completed.

(Note)

To stop pump down, press the [PUMP DOWN] switch again.

To start the pump down again after the compressor is automatically stopped due to an error, turn the power off and open the 3-way valves. Wait 3 minutes, turn the power on and start the pump down again.

When starting the operation after completion of the pump down, turn the power off, and then open the 3-way valves. Wait 3 minutes, turn the power on and perform a test run in the "COOL" operation mode.

# PARTS

DECORATION PANEL  
CG-GFA

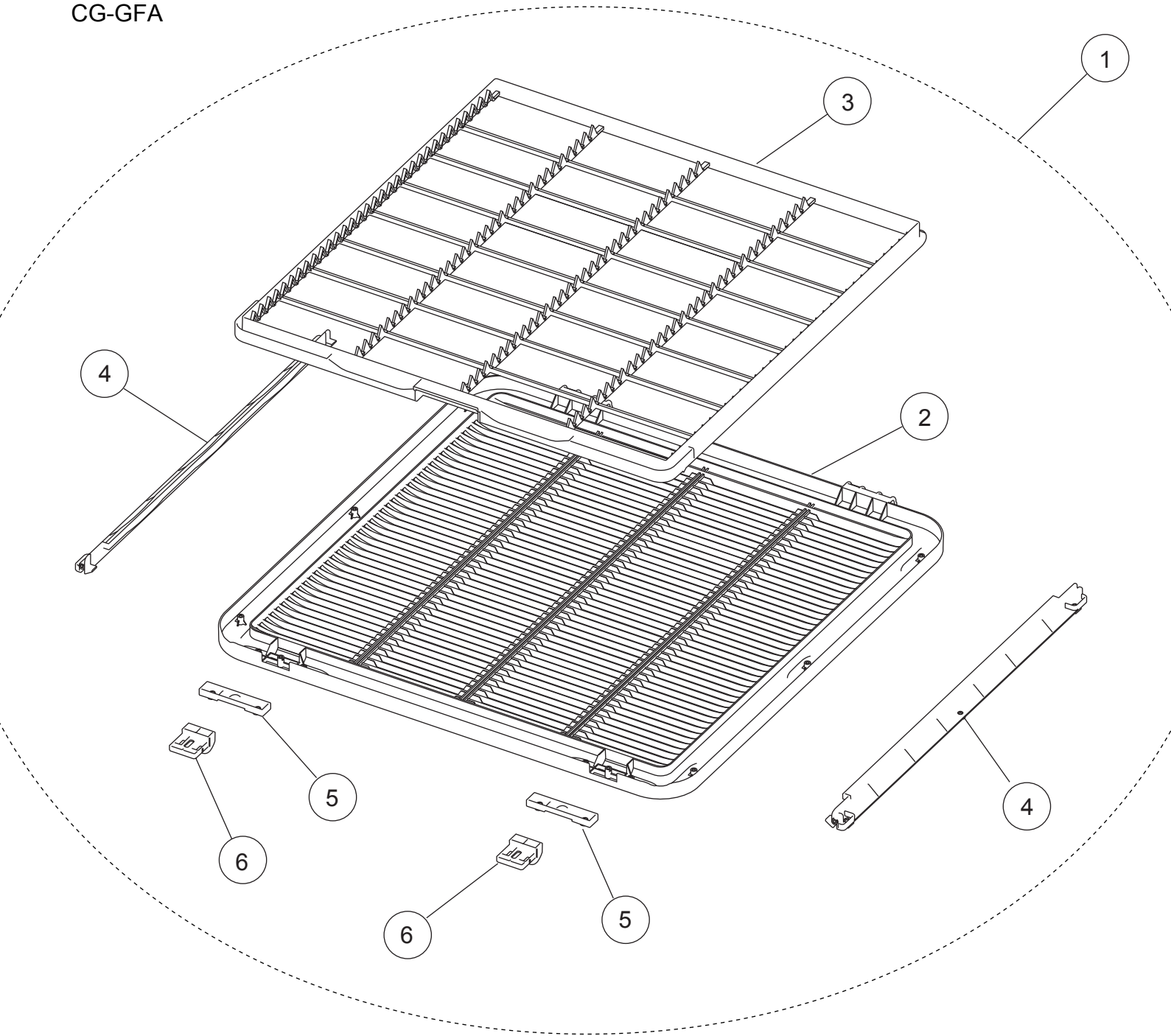

Ref.	Description	Part number
1	Intake Grille Assy	9378565012
2	Intake Grille	9378249011
3	Long Life Filter	9378252011
4	Filter Guide	9378253018
5	Hook Bracket	9378435018
6	Grille Hook	9378250017

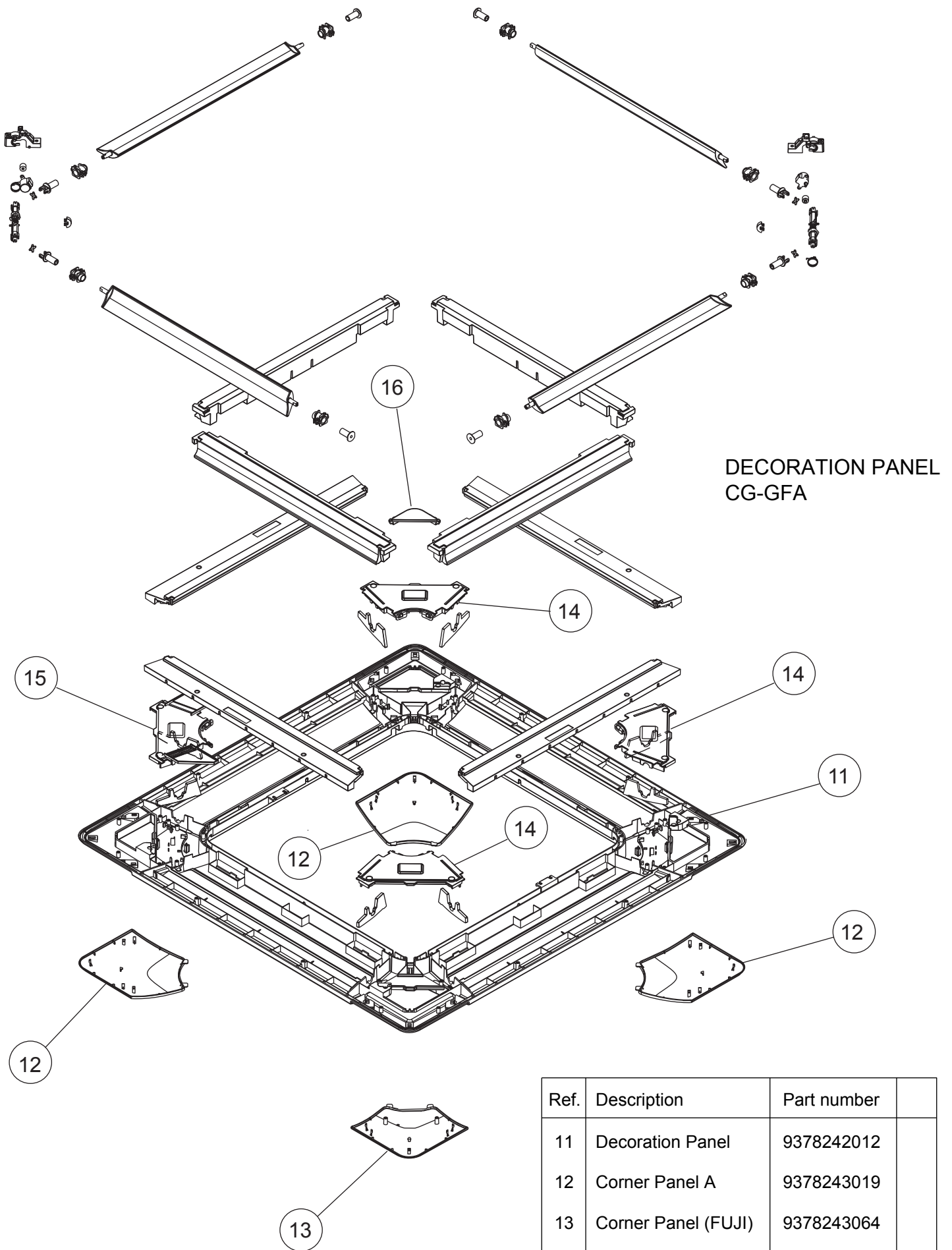

Ref.	Description	Part number	
11	Decoration Panel	9378242012	
12	Corner Panel A	9378243019	
13	Corner Panel (FUJI)	9378243064	
14	Panel Cover A	9378261013	
15	Panel Cover B	9378262010	
16	Drain Cover	9378359017	

DECORATION PANEL  
CG-GFA

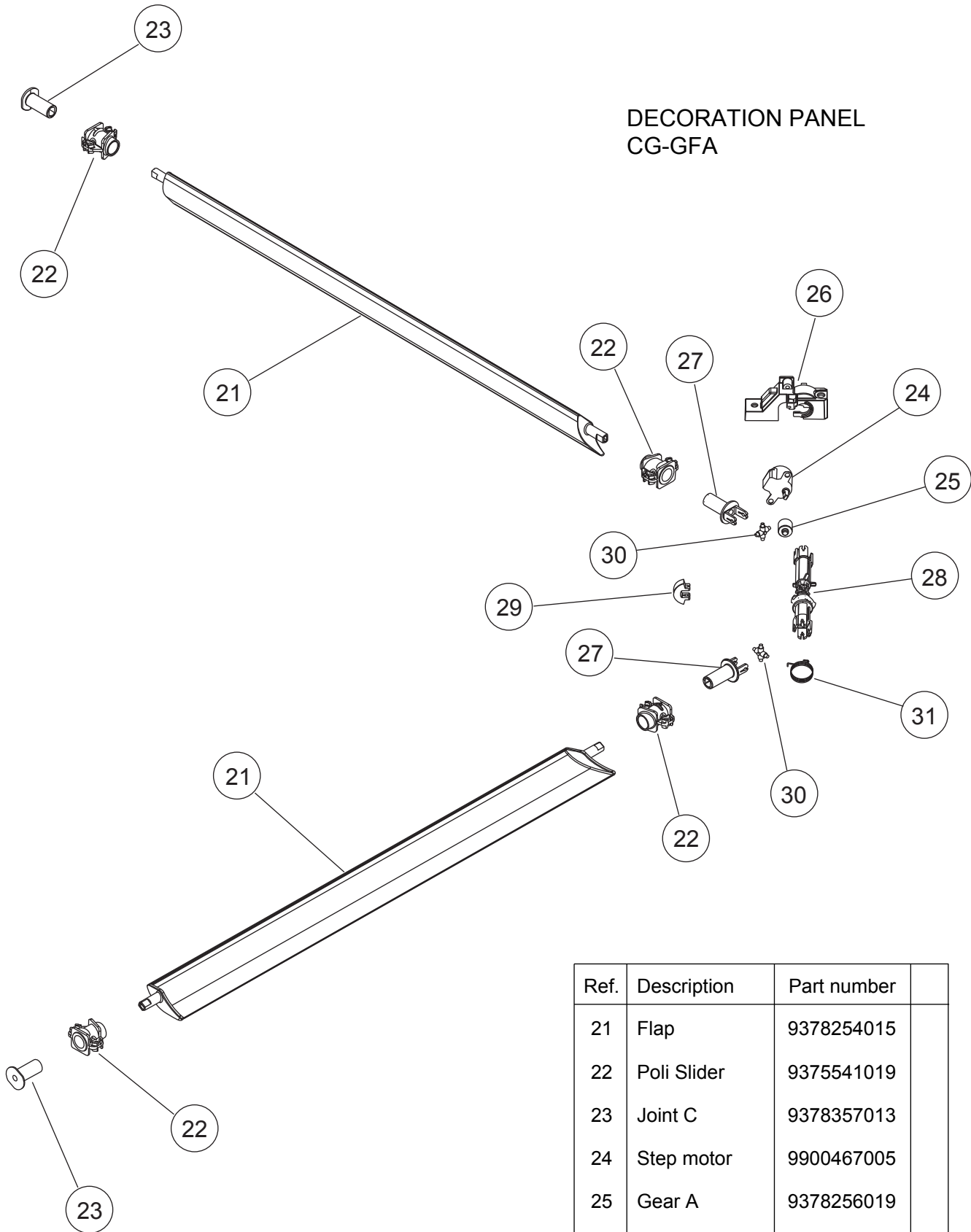

Ref.	Description	Part number
21	Flap	9378254015
22	Poli Slider	9375541019
23	Joint C	9378357013
24	Step motor	9900467005
25	Gear A	9378256019
26	Motor Holder	9378255012
27	Joint A	9378258013
28	Joint B	9378259010
29	Gear B	9378257016
30	Joint Shaft	9378260016
31	Flap Spring	9378356016



# PARTS

## INDOOR UNIT

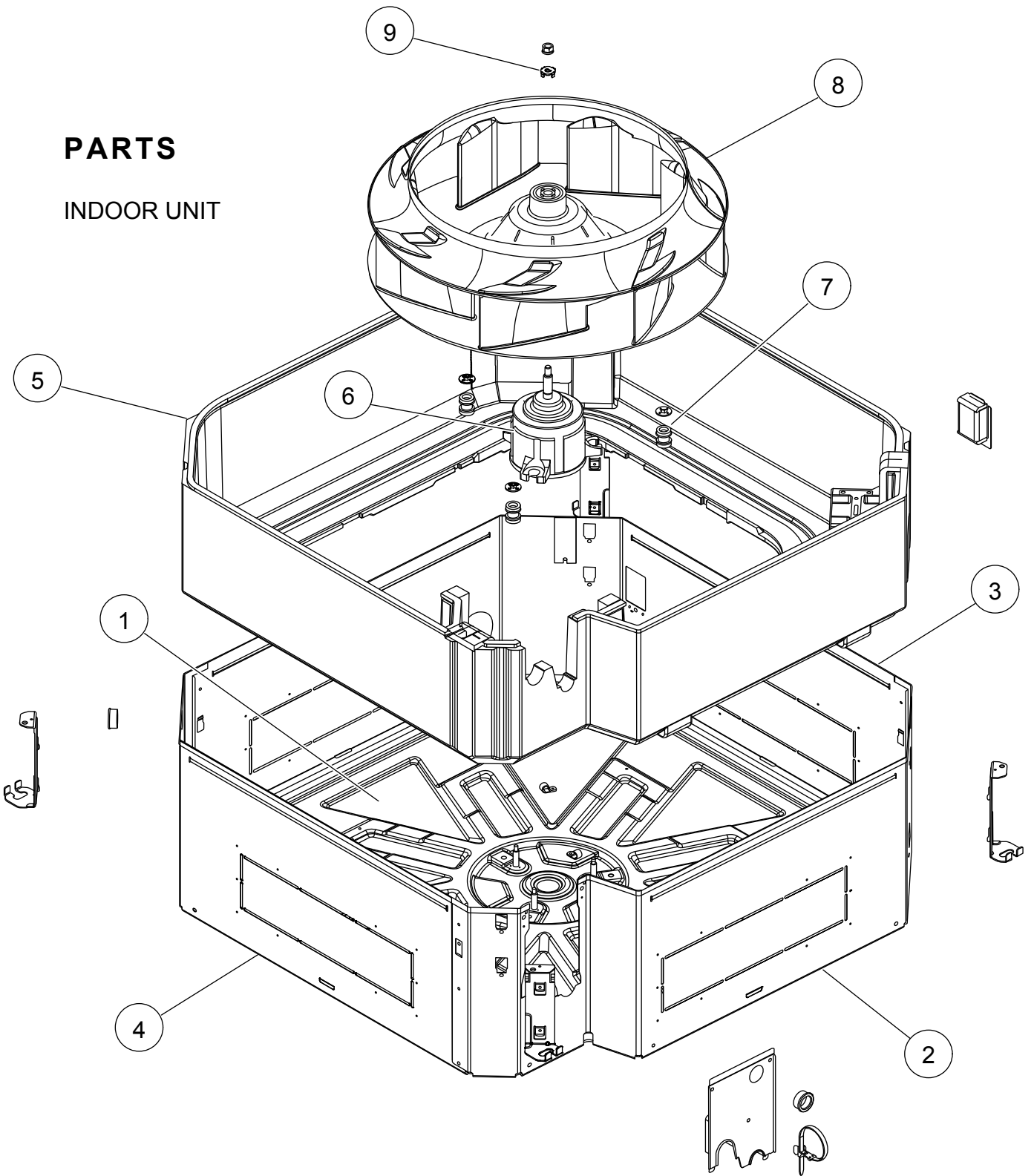

Ref.	Description	Part number
1	Top Plate Assy	9378395015
2	Cabinet A Sub Assy	9378594012
3	Cabinet B Sub Assy	9378595019
4	Cabinet C Sub Assy	9378570016
5	Insulation Box Sub Assy	9378582026

Ref.	Description	Part number
6	Motor, DC Brushless	9602716005
7	Motor Rubber	9378223011
8	Turbo Fan Assy	9378228016
9	Turbo Fan Washer	9378394018

INDOOR UNIT

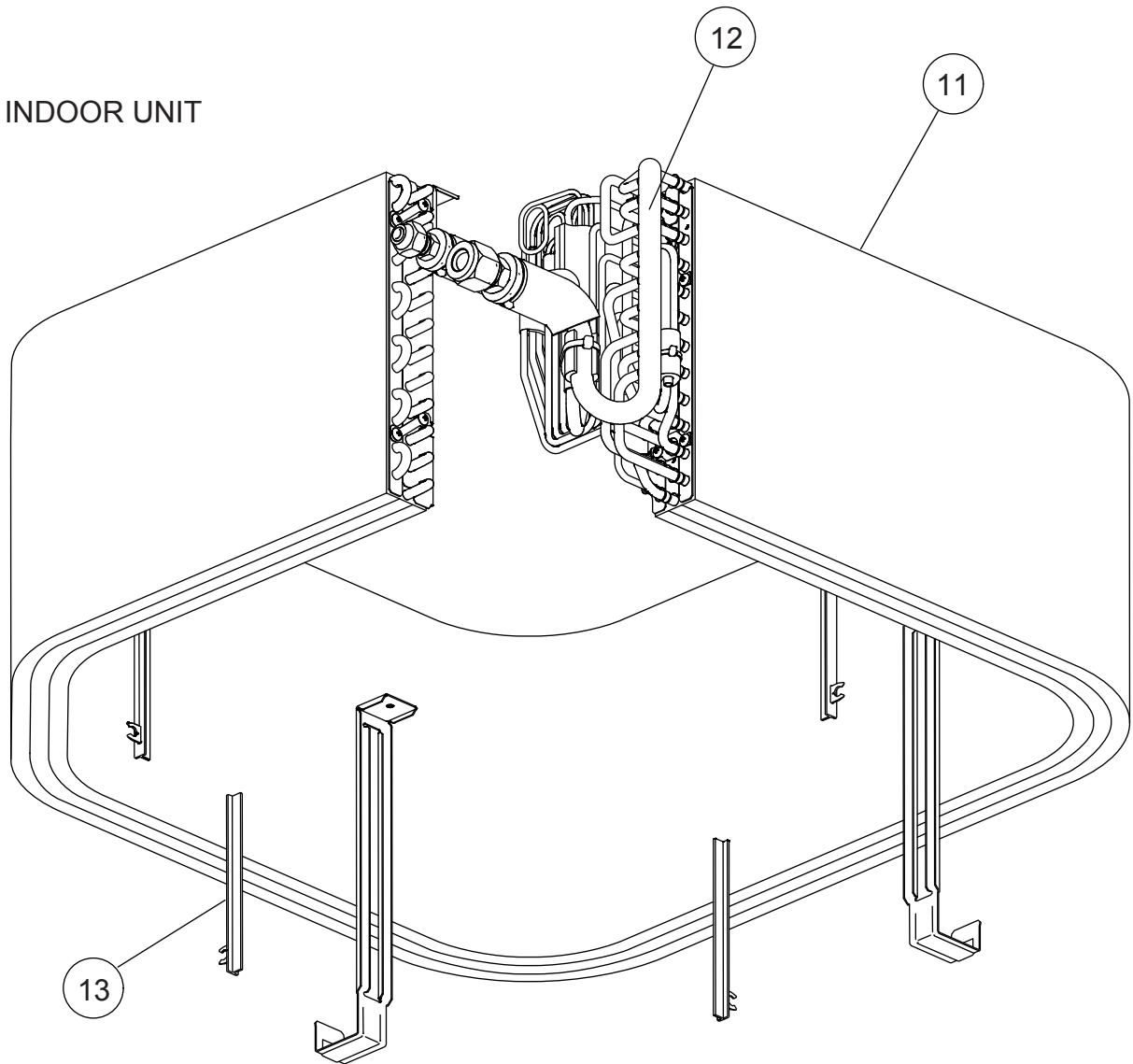

Ref.	Description	Part number	
11	Evaporator Total Assy	9378580053	
12	Coupling Pipe Assy	9373038627	
13	Wind Guide Board	9378236011	

# INDOOR UNIT

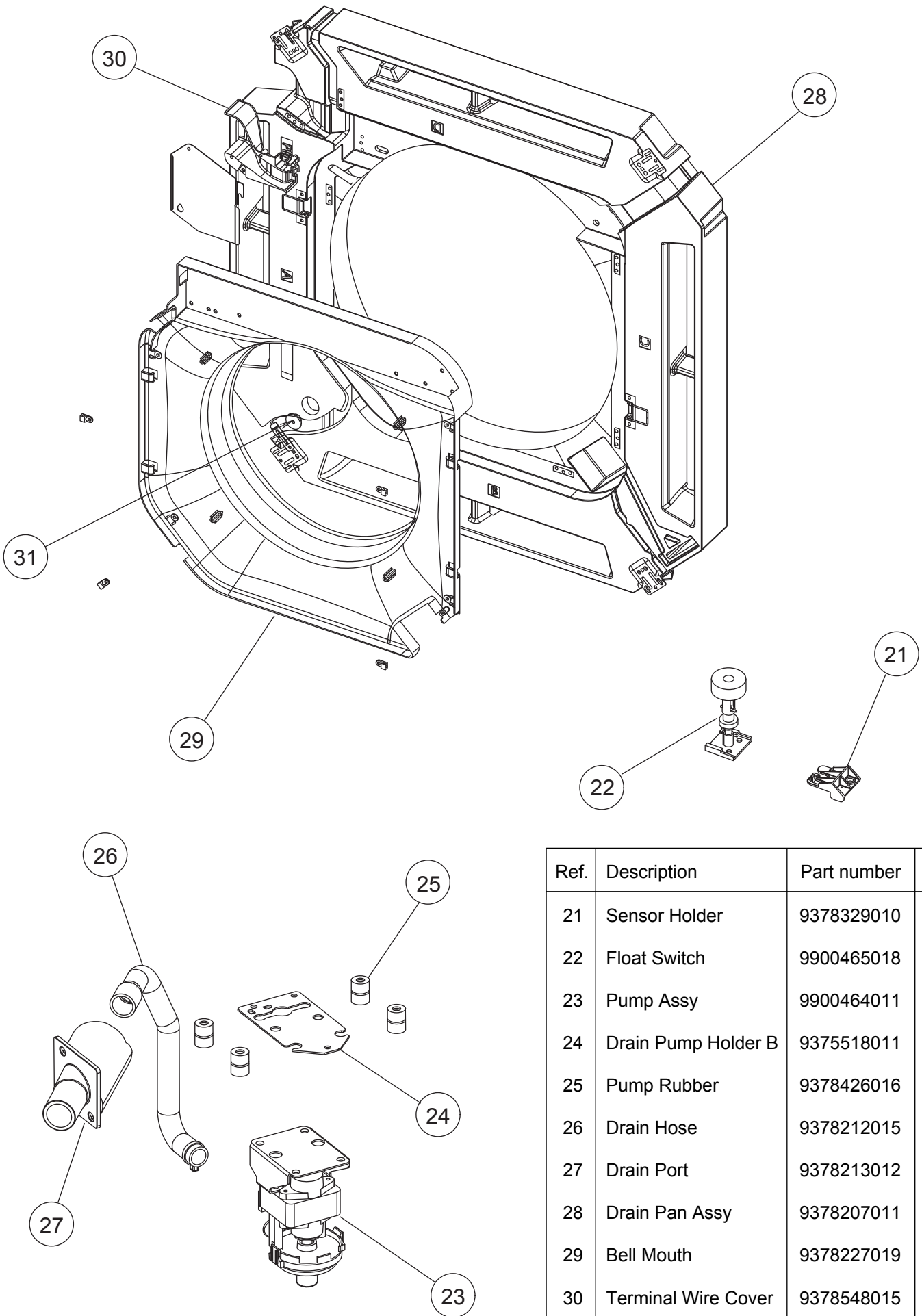

Ref.	Description	Part number
21	Sensor Holder	9378329010
22	Float Switch	9900465018
23	Pump Assy	9900464011
24	Drain Pump Holder B	9375518011
25	Pump Rubber	9378426016
26	Drain Hose	9378212015
27	Drain Port	9378213012
28	Drain Pan Assy	9378207011
29	Bell Mouth	9378227019
30	Terminal Wire Cover	9378548015
31	Drain Cap	9375502010
--	Drain Hose	9379665001

# INDOOR UNIT

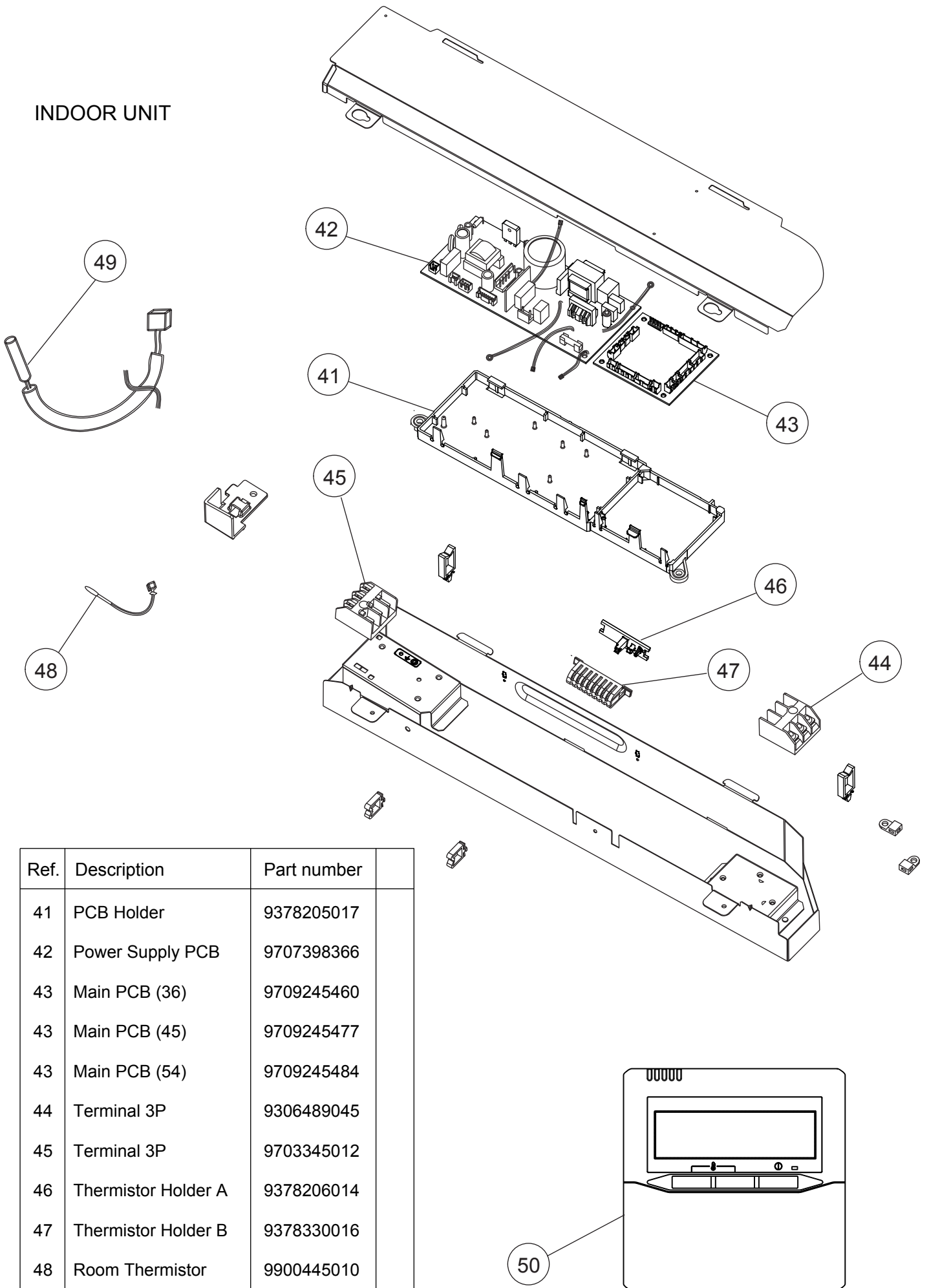

Ref.	Description	Part number
41	PCB Holder	9378205017
42	Power Supply PCB	9707398366
43	Main PCB (36)	9709245460
43	Main PCB (45)	9709245477
43	Main PCB (54)	9709245484
44	Terminal 3P	9306489045
45	Terminal 3P	9703345012
46	Thermistor Holder A	9378206014
47	Thermistor Holder B	9378330016
48	Room Thermistor	9900445010
49	Pipe Thermistor	9900470012
50	Remote Control	9318593013

# PARTS

## OUTDOOR UNIT

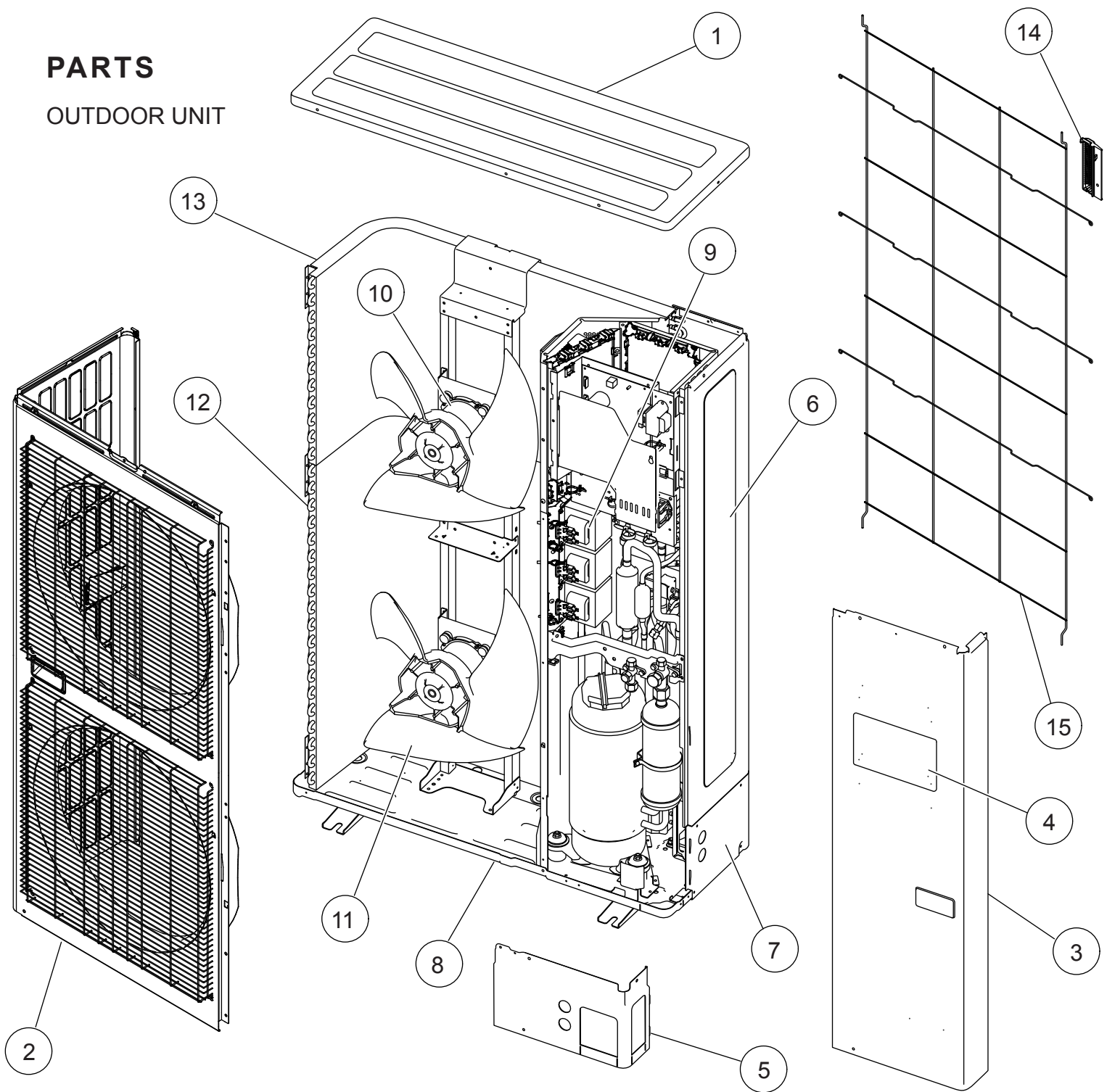

Ref.	Description	Parts number
1	Top Panel Sub Assy	9374417032
2	Front Panel Sub Assy	9374414130
3	Sevice Panel Sub Assy	9374415076
4	Emblem Rear	9318046014
5	Pipe Cover Front	9378861015
6	Right Panel	9378863019
7	Pipe Cover Rear	9378862012
8	Base Assy	9374166220

Ref.	Description	Parts number
9	Reactor Assy	9900641016
10	Motor, DC Brushless	9602843046
11	Propeller Fan Assy	9366378020
12	Condenser A Sub Assy	9374420261
13	Condenser B Sub Assy	9374422081
14	Thermo Holder	9375211011
15	Protective Net	9375381042

# OUTDOOR UNIT

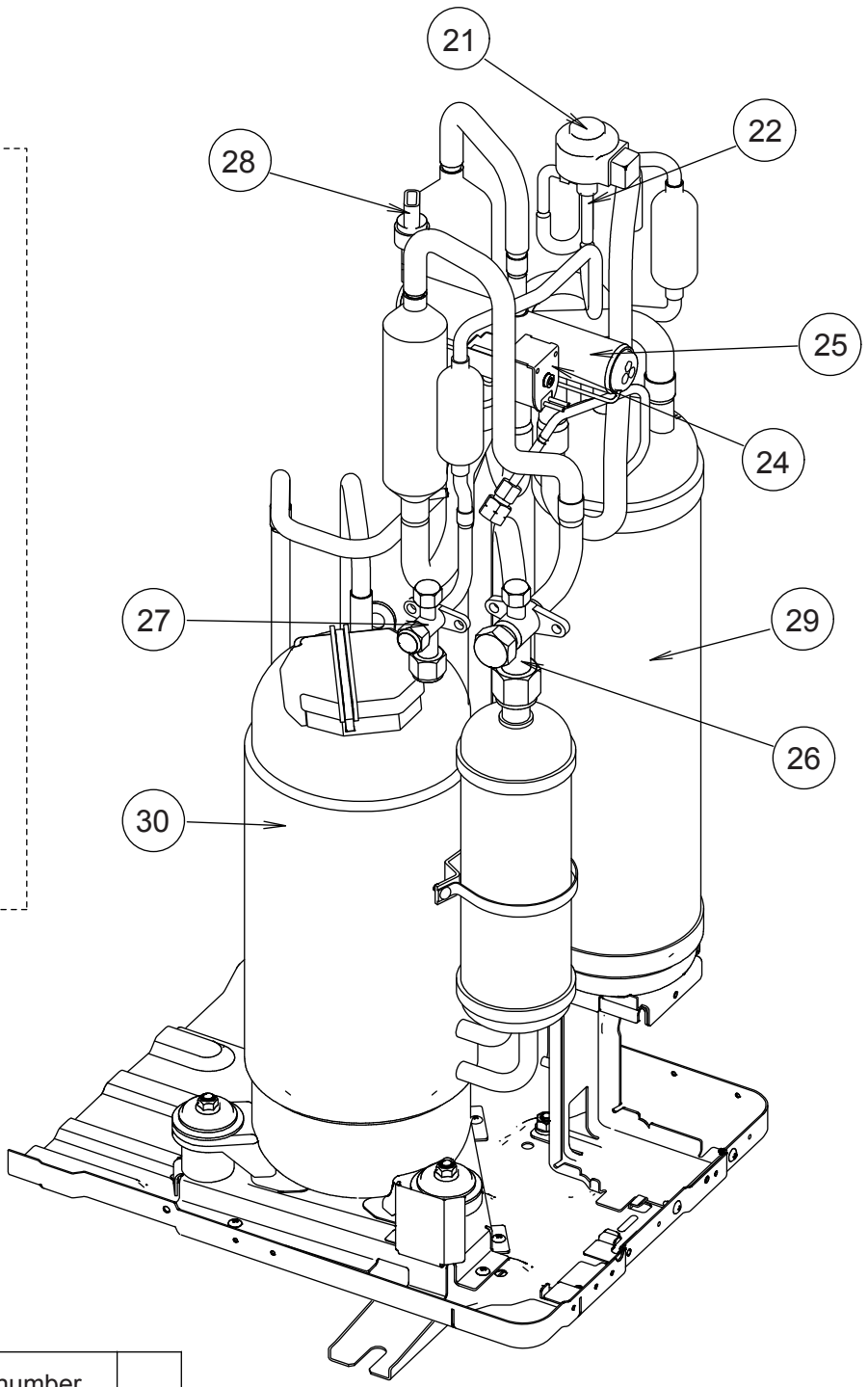
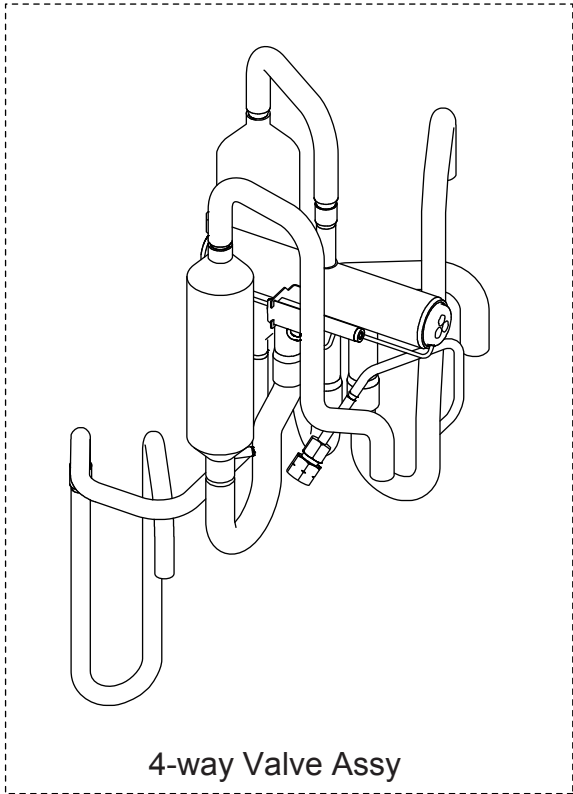

Ref.	Description	Parts number
21	Expansion Valve Coil	9900190057
22	Expansion Valve Assy	9370947182
23	Strainer Assy	9372524039
24	Solenoid	9970113024
25	4-way Valve Assy	9374425273
26	3-way Valve Assy	9379079006
27	3-way Valve Assy	9379077002
28	Sensor	9900505011
29	Accumulator Assy	9375250096
30	Compressor Sub Assy	9374423286

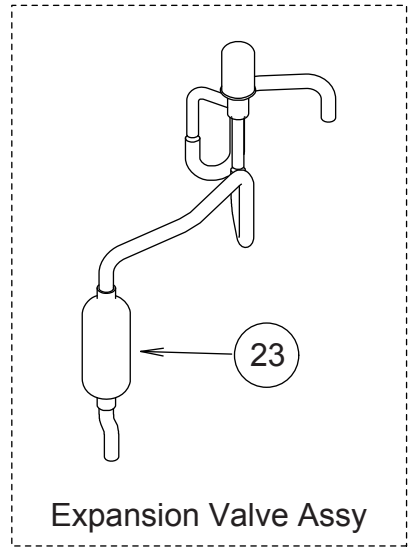



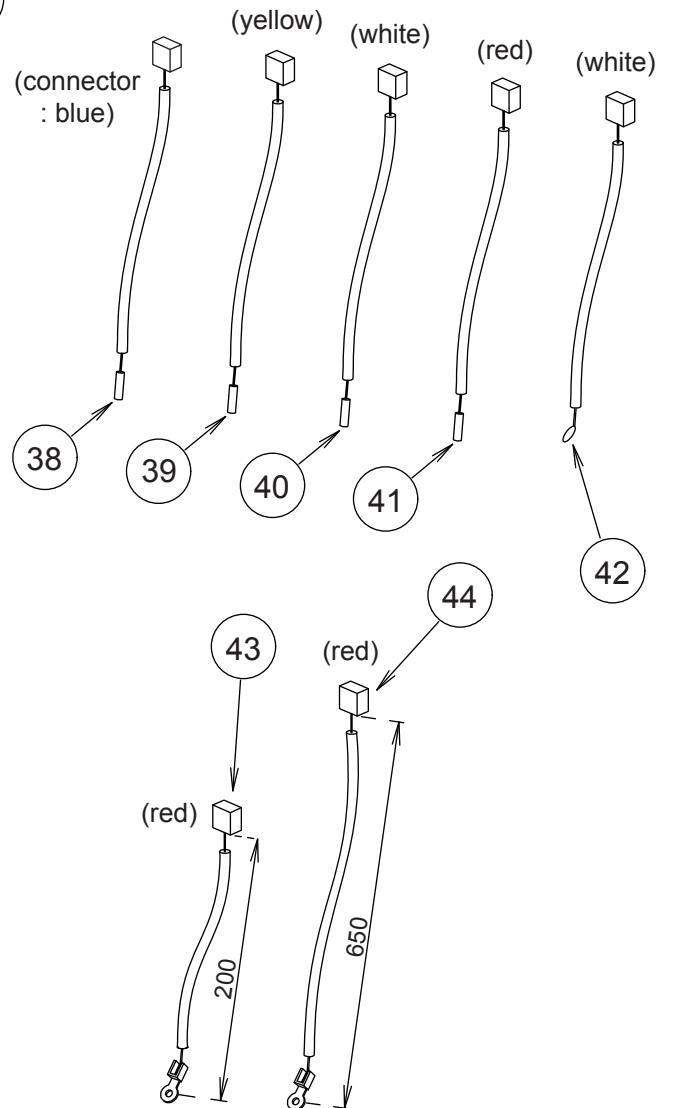
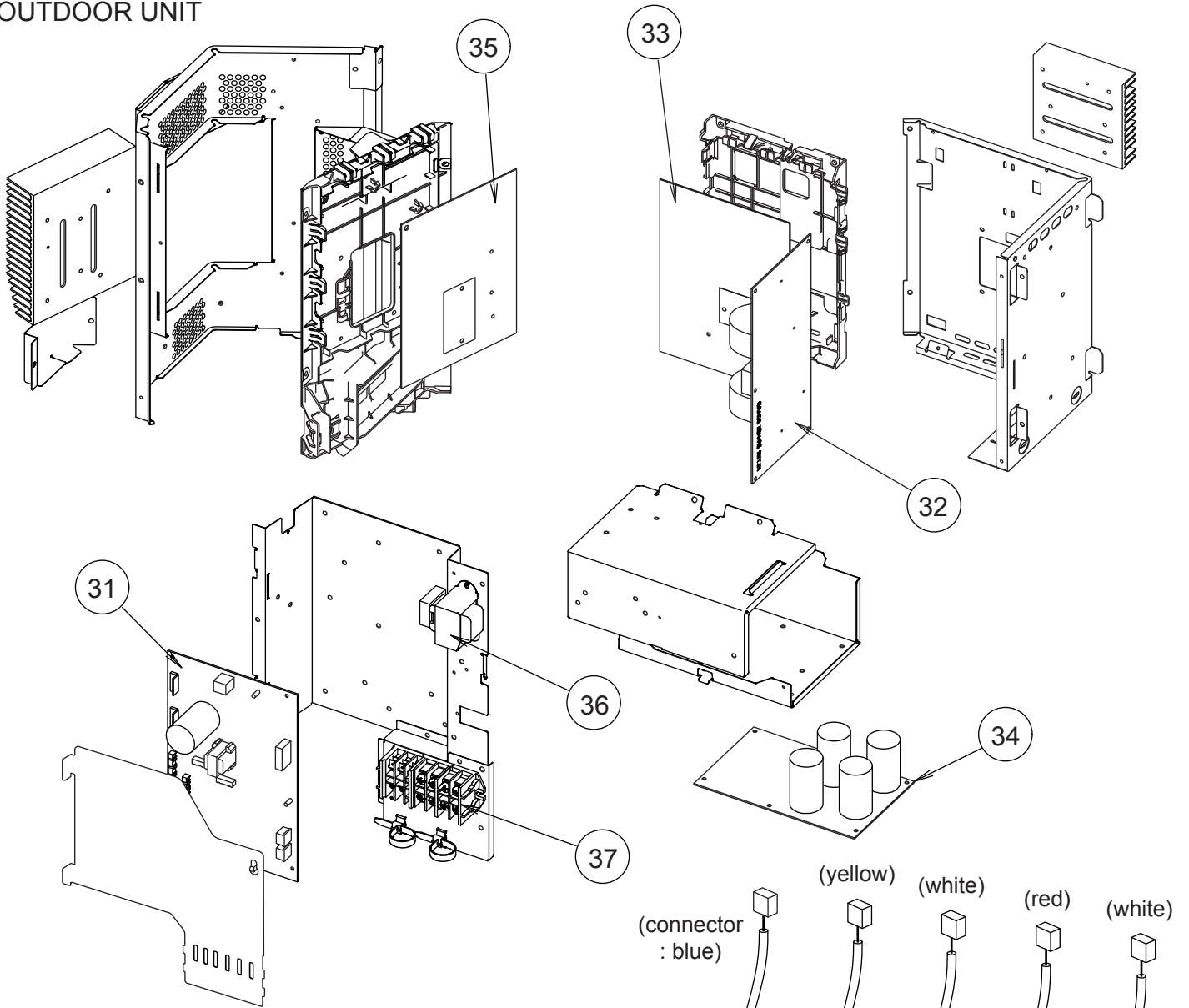





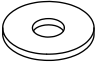
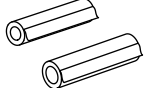

# OUTDOOR UNIT

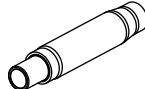

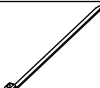

Ref.	Description	Parts number
31	Main PCB (36)	9707627091
31	Main PCB (45)	9707627077
31	Main PCB (54)	9707627084
32	Filter PCB	9707609011
33	Active Filter PCB	9709008010
34	Capacitor PCB	9707608014
35	Transistor PCB	9709010020
36	Reactor Assy	9900481018
37	Terminal	9900428082
38	Compressor Thermistor	9900516000
39	Discharge Thermistor	9900515003
40	Thermistor (Heat Exchanger Mid)	9900513009
41	Thermistor (Heat Exchanger Out)	9900514006
42	Outdoor Thermistor	9900517007
43	Heatsink Thermistor (Inverter)	9900518011
44	Heatsink Thermistor (PFC)	9900518028

# ACCESSORIES

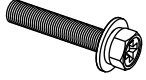
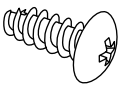
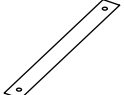

## INDOOR UNIT

Name and Shape	Q'ty	Use	Part number
Template (Carton top) 	1	For installing indoor unit	9378552029
Washer 	8	For installing indoor unit	0700132278
Coupler heat insulation 	2	For indoor side pipe joint	Large:9378173569 Small:9378173521
Insulation 	1	For installing drain pipe	9314450419
Drain hose 	1	For installing drain pipe	9379665001
Hose band 	1	For installing drain pipe	9379757010
Drain hose heat insulation 	1	For installing drain pipe	9378601017
Cable tie (Large) 	3	For electrical wiring	313035356905
Cable tie (Small) 	1	For electrical wiring	313361275805
Wired remote control 	1		9318593013
Remote control cord 	1	For connecting remote control	9372714010
Tapping screw ( $\phi$ 4 x 16) 	2	For installing remote control	0700181108

## DECORATION PANEL

Name and Shape	Q'ty	Use	Part number
Hexigon Screw 	4	For mounting decoration panel	0700087103
Screw 	4	For installing grille holding wire	0700009037
Strap 	4	For installing corner panel	9378558014
Grille holding Wire 	2	For installing intake grille	9378597020

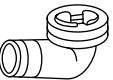
## OUTDOOR UNIT

Name and Shape	Q'ty	Use	Part number
Drain pipe 	1	For drain piping work	9303029015
Drain cap 	2		313166024302
One-touch bush 	2	For power supply cable and connection cable installation	9378779013



## OPTIONAL PARTS

Parts name	Model name	Use
IR receiver unit	UTY-LRH*A2	For air conditioner operation
Wired Remote Control	UTY-RNN*M	For air conditioner operation
Air outlet shutter plate	UTR-YDZC	Install the plate at outlet when carrying out 3-way direction operation
Insulation kit for High humidity	UTZ-KXGA	
External connect kit	UTY-XWZX	For control input/output port
Fresh air intake kit	UTZ-VXGA	To take fresh air
Wide panel	UTG-AGYA-W	Wide panel hides the gap between the ceiling hole and the Decoration panel.
Panel spacer	UTG-BGYA-W	Installation in a space of 56 mm or greater is possible by using panel spacer when the height behind the ceiling is low.

Wired remote control is recommended using simultaneous twin or triple connection.

1204G4048