

Refrigerant
R407C

AIRSTAGETM

Variable Refrigerant Flow System

Multi Air Conditioning System for Buildings



HEAT RECOVERY TYPE

SERVICE MANUAL

FUJITSU GENERAL LIMITED

Multi Air Conditioning System for Buildings

Variable Refrigerant Flow System

SERVICE MANUAL

Refrigerant
R407C

CONTENTS

1. TEST RUN

1-1	CHECK ITEMS BEFORE TEST RUN.....	01-01
1-2	CHECK ITEM DURING TEST RUN.....	01-02
1-3	TEST RUN METHOD.....	01-03
1-3-1	TEST RUN FROM OUTDOOR PC BOARD.....	01-03
1-3-2	TEST RUN FROM REMOTE CONTROLLER.....	01-03
1-4	TEST RUN CONTROL.....	01-05

2. FUNCTION OF PRINTED CIRCUIT BOARD

2-1	PCB LAYOUTS.....	02-01
2-1-1	INDOOR UNIT CONTROL CIRCUIT BOARD.....	02-01
2-1-2	INDOOR UNIT CONTROL CIRCUIT BOARD (COMPACT WALL MOUNTED TYPE).....	02-02
2-1-3	OUTDOOR UNIT CONTROL CIRCUIT BOARD.....	02-03
2-1-4	WIRED REMOTE CONTROLLER, SIMPLE REMOTE CONTROLLER CIRCUIT BOARD.....	02-04
2-1-5	CENTRAL REMOTE CONTROLLER CIRCUIT BOARD.....	02-05
2-1-6	NETWORK CONVERTORS' CIRCUIT BOARD.....	02-06
2-2	MICROPROCESSOR FUNCTION LIST.....	02-08
2-2-1	INDOOR UNIT.....	02-08
2-2-2	OUTDOOR UNIT.....	02-11
2-3	FUNCTION AND SETTING OF EACH SWITCH.....	02-12
2-3-1	INDOOR UNIT(EXCEPT FOR COMPACT WALL MOUNTED TYPE).....	02-12
2-3-2	INDOOR UNIT(COMPACT WALL MOUNTED TYPE).....	02-16
2-3-3	OUTDOOR UNIT.....	02-19
2-3-4	WIRED, SIMPLE REMOTE CONTROLLER.....	02-22
2-3-5	CENTRAL REMOTE CONTROLLER.....	02-24
2-3-6	NETWORK CONVERTOR.....	02-26
2-4	EXTERNAL INPUT & OUTPUT.....	02-28
2-4-1	INDOOR UNIT(EXCEPT FOR COMPACT WALL MOUNTED TYPE).....	02-28
2-4-2	INDOOR UNIT(COMPACT WALL MOUNTED).....	02-30
2-4-3	OUTDOOR UNIT.....	02-31
2-4-4	CENTRAL REMOTE CONTROLLER / PC CONTROLLER.....	02-32
2-4-5	NETWORK CONVERTOR.....	02-34

3. OUTDOOR UNIT OPERATION CONTROL

3-1	COMPRESSOR OPERATION CONTROL.....	03-01
3-1-1	OPERATION / STOP CONDITION.....	03-01
3-1-2	COMPRESSOR OUTPUT PATTERN	03-01
3-1-3	3 MINUTES RESTART PREVENTION (3MIN ST).....	03-01
3-1-4	COMPRESSOR RECOVERY OPERATION.....	03-02
3-2	HEAT EXCHANGE CAPACITY CONTROL.....	03-03
3-3	OUTDOOR FAN MOTOR CONTROL.....	03-04

3-4	EXPANSION VALVES 1 AND 2 CONTROL.....	03-06
3-5	CIRCULATING SAVE AMOUNT CONTROL.....	03-07
3-6	SOLENOID VALVE 2 CONTROL.....	03-07
3-7	DEFROSTING CONTROL.....	03-08
3-8	OIL RETURN CONTROL.....	03-09
3-9	OIL RECOVERY CONTROL.....	03-10
3-10	PROTECTION FUNCTIONS.....	03-11

4. INDOOR UNIT OPERATION

4-1	TIMER CONTROL.....	04-01
4-2	FAN CONTROL.....	04-06
4-2-1	"AUTO" POSITION.....	04-06
4-2-2	"LOW", "MED" AND "HIGH" POSITION.....	04-06
4-3	MASTER CONTROL.....	04-07
4-3-1	OPERATION MODE CONTROL.....	04-07
4-3-2	AUTO CHANGEOVER.....	04-08
4-3-3	"COOL" POSITION.....	04-09
4-3-4	"HEAT" POSITION.....	04-09
4-3-5	"FAN" POSITION.....	04-09
4-4	LOUVER CONTROL.....	04-10
4-5	ENERGY SAVE OPERATION.....	04-13
4-6	ANTI FREEZE CONTROL.....	04-14
4-7	ELECTRONIC EXPANSION VALVE CONTROL.....	04-15
4-8	AUTO RESTART.....	04-15
4-9	DRAIN PUMP OPERATION.....	04-15

5. TROUBLESHOOTING

5-1	INDOOR UNIT.....	05-01
5-1-1	NORMAL OPERATION DISPLAY.....	05-01
5-1-2	ABNORMAL OPERATION DISPLAY.....	05-02
5-2	OUTDOOR UNIT.....	05-03
5-2-1	NORMAL OPERATING DISPLAY.....	05-03
5-2-2	ABNORMAL OPERATION DISPLAY.....	05-04
5-3	REMOTE CONTROLLER.....	05-05
5-3-1	WIRED REMOTE CONTROLLER.....	05-05
5-3-2	SIMPLE REMOTE CONTROLLER.....	05-05
5-3-3	CENTRAL REMOTE CONTROLLER.....	05-06
5-4	NETWORK CONVERTOR.....	05-09
5-5	ERROR CODE & TROUBLESHOOTING.....	05-10
5-5-1	TROUBLE SHOOTING WITH ERROR CODE.....	05-10
5-5-2	TROUBLE SHOOTING WITH NO ERROR CODE.....	05-36
5-6	CASE SUCH AS THESE ARE NORMAL.....	05-46

6. APPENDING DATA 1 (INSTALLATION)

6-1	ADDITIONAL CHARGE.....	06-01
6-2	ADDRESS SETTING.....	06-02

6-2-1	KINDS OF ADDRESS AND SETTING RANGE.....	06-02
6-2-2	ADDRESS SETTING FOR COMPACT WALL MOUNTED TYPE INDOOR UNIT.....	06-04
6-2-3	EXAMPLES OF SYSTEM SETTING.....	06-05
6-3	PUMP DOWN METHOD.....	06-09
6-3-1	START AND STOP OF THE PUMP DOWN.....	06-09
6-3-2	A FLOW CHART OF PUMP DOWN.....	06-09
6-4	TOOLS.....	06-10
6-5	PRECAUTIONS FOR INSTALLATION.....	06-11
6-6	PRECAUTIONS FOR SERVICING.....	06-13
6-7	IN USE OF THE NEW REFRIGERANT R407C.....	06-14
6-7-1	WHAT IS CFC/HCFC/HFC ?.....	06-14
6-7-2	CHARACTERISTICS OF R22 AND R407C.....	06-14
6-7-3	DEFERENCE FROM CONVENTIONAL MODEL(R22) AND PRECAUTIONS...	06-15

7. APPENDING DATA 1 (UNIT)

7-1	REFRIGERANT PIPE SYSTEM DIAGRAM.....	07-01
7-2	CHARACTERISTICS OF SENSORS.....	07-02
7-2-1	THRMISTOR.....	07-02
7-2-2	PRESSURE SENSOR.....	07-04
7-2-3	ELECTRIC EXPANSION VALVE.....	07-04
7-2-4	RB UNIT.....	07-04
7-2-5	OTHERS.....	07-05
7-3	WIRING DIAGRAM.....	07-06
7-3-1	INDOOR UNIT.....	07-06
7-3-2	OUTDOOR UNIT.....	07-18
7-4	OUTDOOR INTERNAL LAYOUT.....	07-19
7-5	MODEL DESIGNATION	07-20

Refrigerant
R407C

AIRSTAGE™

1 . TEST RUN

1. TEST RUN

1-1 CHECK ITEMS BEFORE TEST RUN

Before test run, check the following items.

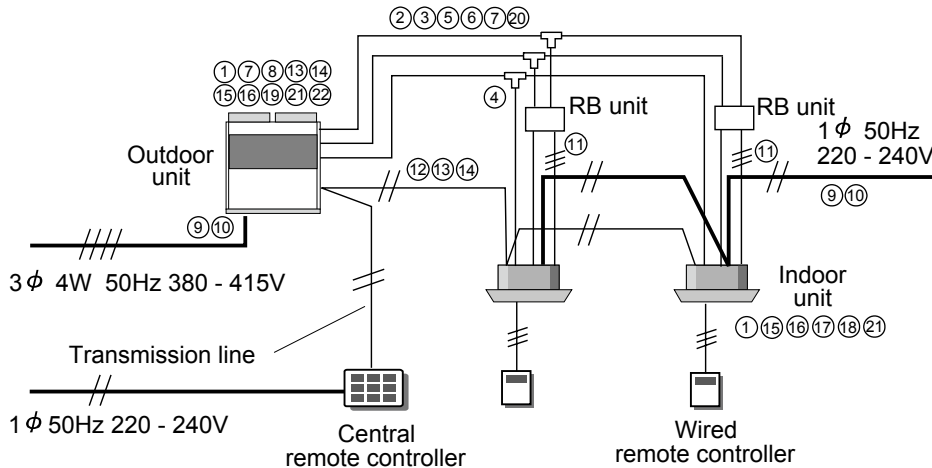

- ① Is the selection of the outdoor unit and the indoor units correct?
(Check the number of connected indoor units, total capacity of the indoor units)
- ② Is the piping length correct?
(Ex. Maximum piping length : 100m)
- ③ Is the diameter of the selected pipe correct?
- ④ Is the diameter selected separation kit correct?
- ⑤ Doesn't gas leak?
- ⑥ Have the vacuum process done enough time?
- ⑦ Is the refrigerant flow correct?
- ⑧ Is the additional refrigerant charge amount correct?
(Note the charge amount to control box cover)
- ⑨ Are the power supply cables connected?
(Power supply for the indoor unit and outdoor unit is separated.)
- ⑩ Is the spec. for the power supply cable correct?
- ⑪ Is the RB unit cable connected?
- ⑫ Is the length of the transmission line under the limit?
- ⑬ Is the spec. for the transmission cable correct?
(non-polar 2-core, 0.75-1.25mm²)
- ⑭ Is the transmission cable connected to all units?
- ⑮ Is the remote controller cable connected to units?
- ⑯ Is not the power supply cable connected to transmission and remote controller terminal?
- ⑰ Are the addresses set? (Ex. Refrigerant circuit address, indoor unit address, remote controller address, etc.)
- ⑱ Have the all settings done on the PCB?
- ⑲ Is the ball valve opened?
- ⑳ Is the pipe heat-insulated which have the enough thickness?
- ㉑ Is the drain water-flow correct?
- ㉒ Is the power supplied to crank case heater for more than 12 hours before the start of test run at outdoor temperature of 20°C or below?

1-2 CHECK ITEM DURING TEST RUN

During the test run operation, check the following items.

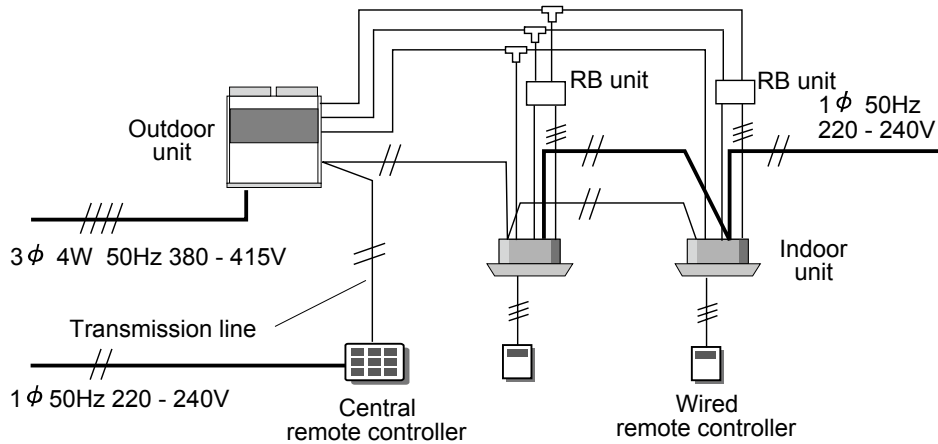

- ① When the power supply turn on, check the following items.

Outdoor unit : LED 1 lights continuously.

if LED flashing, it means error occurs, check the error and solve the problem.

Indoor unit : LED RED (operation lamp) & GREEN (timer lamp) lights flash alternately. (Auto restart setting: Invalidity)

All LEDs go off. (Auto restart setting : Validity)

RC : Timer display indicates

When errors occur, don't advance towards the following step before a complete settlement of all these errors.

- ②

Start the Indoor unit test run from remote controller one by one (Refer to 1-3-2)

Check the following item.

Indoor unit

LED (red&green) light flash at the same time slowly.

Louver operates to open.

Fan rotates

Air flow comes

(Drain pump operation)

RC signal receive

Outdoor unit

Corresponds from indoor unit signal

Compressor start to operates

Fan rotates

Measure the following item.

Indoor unit

Air intake temp.

Air flow temp.

Outdoor unit

Outdoor temp.

Discharge pipe temp.

Suction pipe temp.

High pressure

Low pressure

- ③ Continue the operation about 10 minutes.

- ④ When there is no problem, check the next indoor unit.

After every indoor unit is checked by test run, please do test run using all of the indoor units and check them.

1-3 TEST RUN METHOD

Supply power to the crankcase heater for 12 hours prior to the start of operation if the outdoor temperature is lower than 20 °C. The following is the procedure for the test run operation.

1-3-1 TEST RUN FROM OUTDOOR PC BOARD

By setting DIP SW1-1 and SW1-2 on control PC board of outdoor unit, cooling test run or heating test run for all the indoor units in the same refrigerant system can be performed.

SW1-2	SW1-1	Operation Mode	Select position of [SW1-2, SW1-1]
OFF	OFF	Normal Operation	[OFF,ON] or [ON,OFF] → [OFF,OFF]
ON	ON	Normal Operation	[OFF,ON] or [ON,OFF] → [ON,ON]
ON	OFF	Heating Test Run	[OFF,OFF] → [ON,OFF]
OFF	ON	Cooling Test Run	[OFF,OFF] → [OFF,ON]

1-3-2 TEST RUN FROM REMOTE CONTROLLER

1) Standard wired remote controller

Stop the indoor and outdoor units. Push the FAN CONTROL button and MASTER CONTROL button simultaneously for more than three seconds. The air conditioner will start to conduct a test run and TEST will display on the remote controller display. However, the SET TEMP./DAY setting button does not have function, but all other buttons, displays, and protection functions will operate.

UTB - * LA

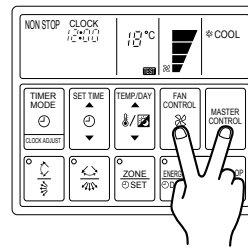

UTB - * LB

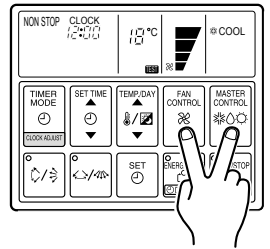

- To stop test run, push the START/STOP button of the standard wired remote controller.
- For the operation method, refer to the operating manual and perform operation check.
- Check that there are no abnormal sounds or vibration sounds during test run operation.

2) Standard wireless remote controller

- Press the test button of UTB - *SA or short two pieces of metallic bodies in the test run frame of UTB - *VA, while the air conditioner is running.
- To stop test run operation, push START/STOP button of the wireless remote controller.

When the air conditioner is being test run, the OPERATION and TIMER lamps of indoor unit flash slowly at the same time.

UTB - *SA

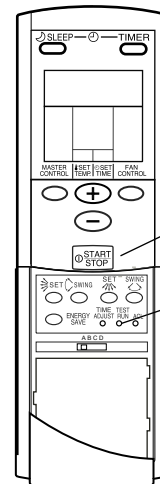

UTB - *VA

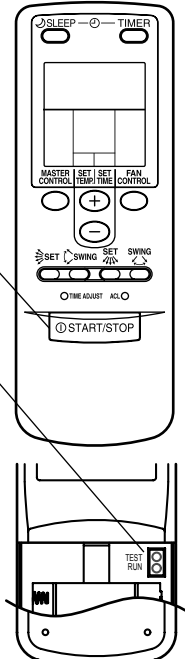

3) Simple remote controller

Stop the indoor and outdoor units. Push the remote controller button and button simultaneously for more than three seconds. The air conditioner will start to conduct a test run and will display on the temperature display.

However the setting button does not have function but all other buttons, displays and protection functions will operate.

- To stop test running press the button of the simple remote controller.
- For the operation method refer to the operating manual and perform operation check.
- Check that there are no abnormal sounds or vibration sounds during test run operation.

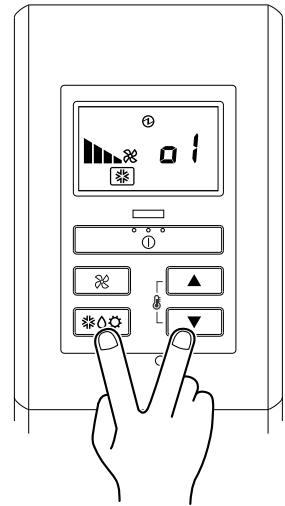

4) Central remote controller

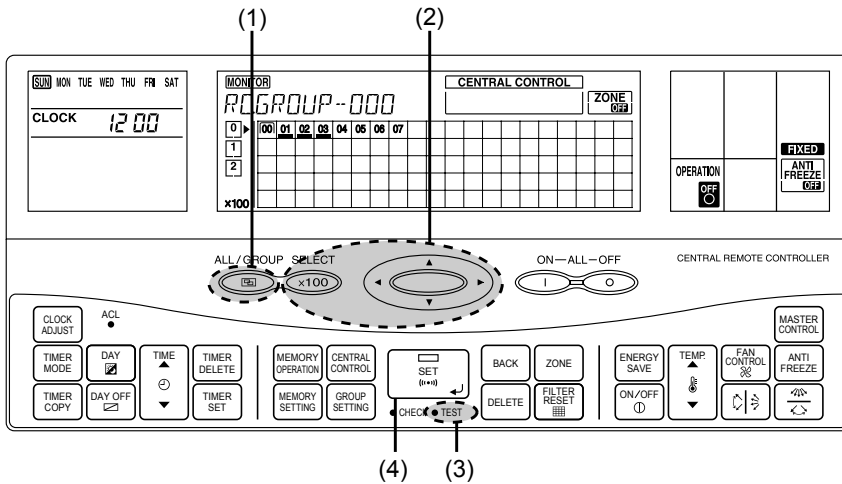

Remote control group operation settings are performed in the control mode. The following procedure for the setting is the same for any of the control modes: Individual mode / Group control mode / All control group.

(1) Push to select control mode from among Individual control mode / Group control mode / All control.

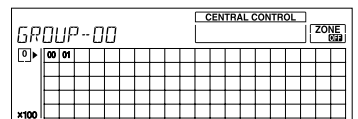

(2) When Individual control mode is selected, use and to select the desired central control number, then go to (3).

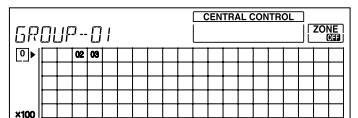

When Group control mode is selected use to select the desired group number, then go to (3).

When All control mode is selected, go directly to (3).

(3) Press and will light up. The operation setting is applied to the selected units.

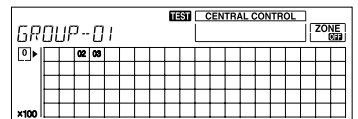

(4) Press to send the signal and test run setting is sent to the indoor unit.

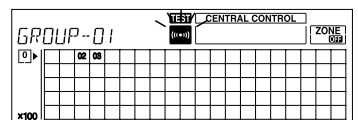

will flash as the signal is being transmitted.

60 minutes' test run starts.

To stop the test run, do the same procedure as those for stop a normal operatin.

It is possible to change the settings for the operation mode (heating / cooling) and fan setting.

(5) Once the signal has been transmitted, the segment and LED will go out. The indoor unit will start test run operation.

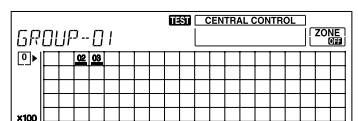

NOTE : If the test run is stopped midway, do the operation shown in (3) above and press .

OPERATION

will come on, then do the operation shown in (4). Test run will stop.

1-4 TEST RUN CONTROL

- 1) When the test run signal is transmitted from standard wired, wireless remote controller, simple remote controller and central remote controller.
 - (1) The test run operation starts and the electric expansion valve is controlled to a maximum flow, regardless of the temperature condition.
 - (2) De-frosting and frost prevention operation has priority over item(1).
 - (3) After 60 minutes passes, the test run stops. However, the operation continues in same operating mode.
- 2) When the test run signal is transmitted from the outdoor unit.
 - (1) Whether state of the indoor unit operates or stops, All units in the same refrigerant system will start to conduct a test run in accordance with the operation mode set by DIP SW 1-1 and SW 1-2 of outdoor unit (see 1 - 3 - 1).
 - (2) Test running initialization is shown below.

Operating Mode	Cooling	Heating
Fan speed	Hi	Hi
Room Temperature Indication	18	30
Vertical Air Direction Panel	Position ①	Position ④
Horizontal Air Direction Panel	Position ③	Position ③
Swing	OFF	OFF

※ Please refer to '4-4 LOUVER CONTROL' in this manual and find the definition for air direction panel position.

Refrigerant
R407C

AIRSTAGE™

2 . FUNCTION OF PRINTED CIRCUIT BOARD

2. FUNCTION OF PRINTED CIRCUIT BOARD

2-1 PCB LAYOUTS

2-1-1 INDOOR UNIT CONTROL CIRCUIT BOARD

Indoor unit			
DIP SW	SW 1	1	Ceiling height setting 1
		2	Ceiling height setting 2
		3	Room temp correct coefficient of heating 1
		4	Room temp correct coefficient of heating 2
	SW 2	1	Room temp correct coefficient of cooling
		2	Forbidden
		3	Filter check validity / invalidity
		4	Auto restart validity / invalidity
	SW 3	1	Forbidden(Indoor unit fan speed switch 1)
		2	Forbidden(Indoor unit fan speed switch 2)
		3	Forbidden(Indoor unit fan speed switch 3)
		4	External input select edge / pulse
	SW 4	1	Forbidden(Indoor unit model code)
		2	Forbidden(Indoor unit model code)
		3	Forbidden(Indoor unit model code)
		4	Forbidden(Indoor unit model code)
SW 5	1	Wireless remote controller custom code switch 1	
	2	Wireless remote controller custom code switch 2	
	3	Frost prevention temperature shift switch	
	4	Draft prevention setting switch	
Rotary SW	SW 6	Indoor unit address switch	
	SW 7	Forbidden	
	SW 8	Refrigerant circuit address 1	
	SW 9	Refrigerant circuit address 2	
	SW 10	Remote controller address	

SWITCH POSITION

Indoor unit control circuit board

For AB / AU / AR types indoor unit

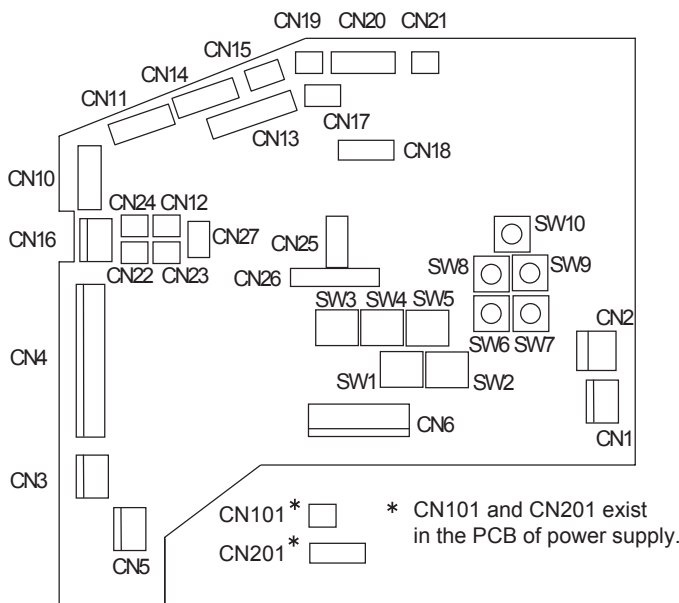

For AS / AW types indoor unit

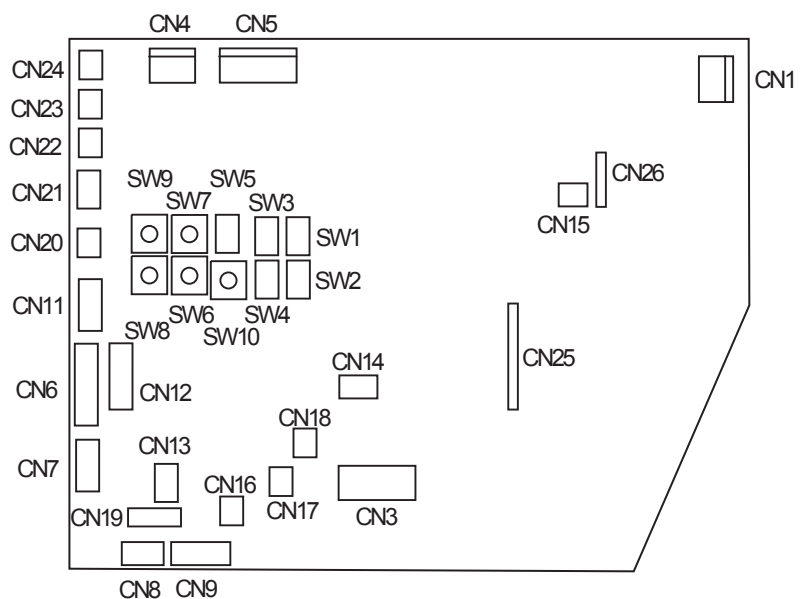

2-1-2 INDOOR UNIT CONTROL CIRCUIT BOARD (COMPACT WALL MOUNTED TYPE)

Indoor unit			
DIP SW	SW 1	1	Forbidden(Indoor unit fan speed switch 1)
		2	Forbidden(Indoor unit fan speed switch 2)
		3	Forbidden(Indoor unit model code)
		4	Forbidden(Indoor unit model code)
	SW 2	1	Indoor unit address switch
		2	Indoor unit address switch
		3	Auto restart validity / invalidity
		4	Forbidden
	SW 3	1	Refrigerant circuit address switch
		2	Refrigerant circuit address switch
		3	Refrigerant circuit address switch
		4	Forbidden
Rotary SW	SW 4	Indoor unit address switch	
	SW 5	Refrigerant circuit address switch	
Jumper wire	JM 1	Wireless remote controller custom code	
	JM 2	Wireless remote controller custom code	

■ SWITCH POSITION

- Compact wall mounted type indoor unit control circuit board

Controller PCB

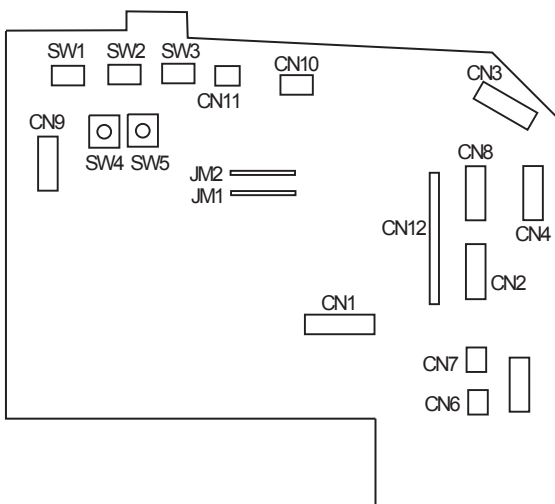

Power supply PCB

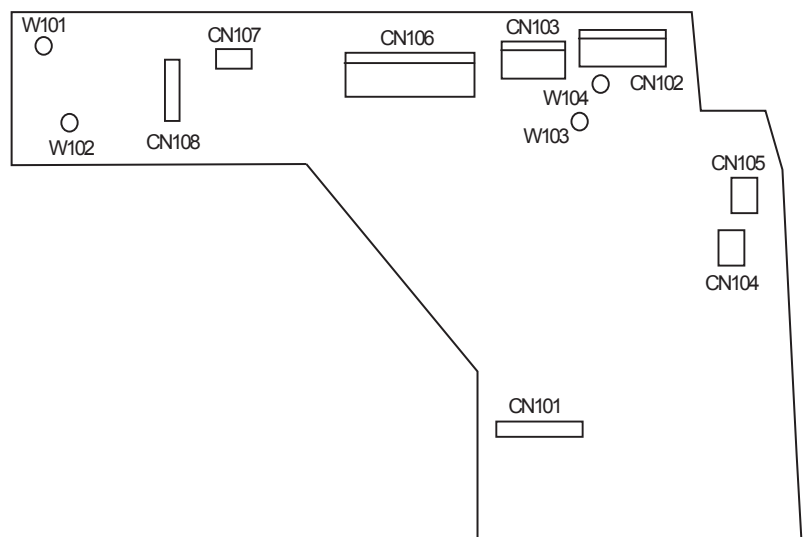

2-1-3 OUTDOOR UNIT CONTROL CIRCUIT BOARD

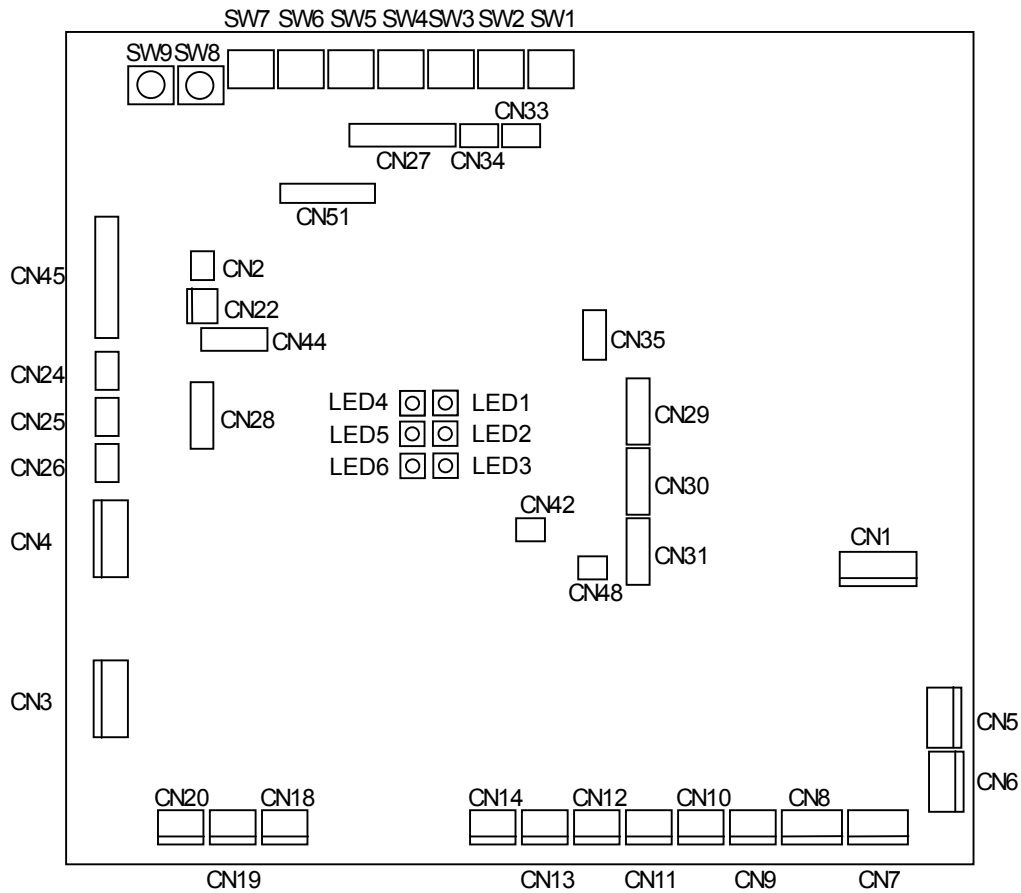

Outdoor unit			
DIP SW	SW 1	1	Test run(Cooling)
		2	Test run(Heating)
		3	Pump down operation
		4	Forced defrost operation
	SW 2	1	Silent operation mode
		2	Snow falling protection fan mode
		3	EEV initialization
		4	Forced oil recovery operation
	SW 3	1	Forbidden
		2	Forbidden
		3	Forbidden
		4	Forbidden
	SW 4	1	Defrost temperature setting SW1
		2	Defrost temperature setting SW2
		3	Forbidden
		4	Forbidden
	SW 5	1	Forbidden
		2	Forbidden
		3	Base heater validity / invalidity
		4	Forbidden
	SW 6	1	Forbidden
		2	Forbidden
		3	Forbidden
		4	Forbidden
	SW 7	1	System type switch 1
		2	System type switch 2
		3	Forbidden
		4	Forbidden
ROTARY SW	SW 8	Refrigerant circuit address switch 1	
	SW 9	Refrigerant circuit address switch 2	

2-1-4 WIRED REMOTE CONTROLLER, SIMPLE REMOTE CONTROLLER CIRCUIT BOARD

Wired remote controller

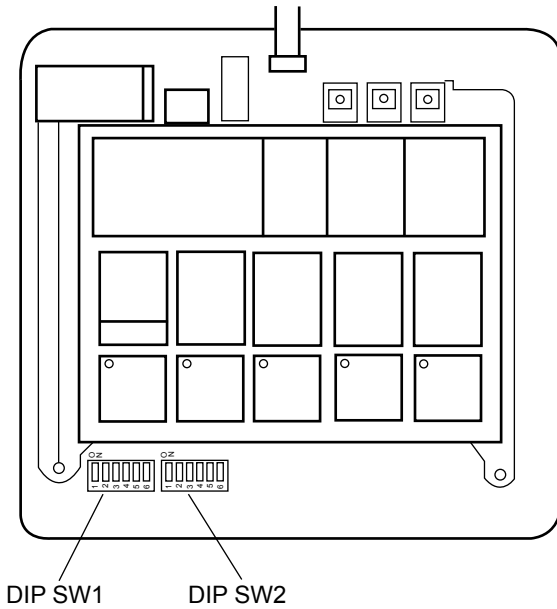

Simple remote controller

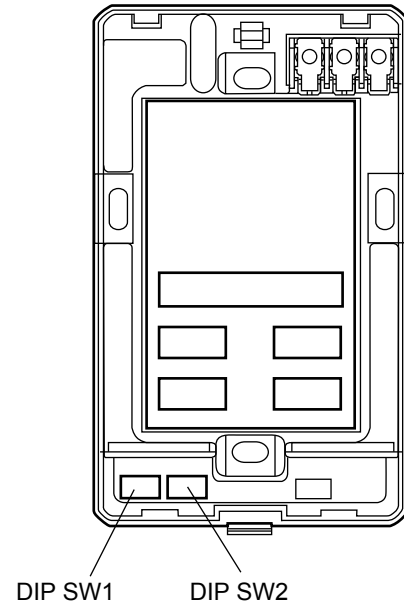

Wired & Simple remote controller				
DIP SW	SW 1	1	Remote controller switch 1(Terminator)	
		2	Indoor unit connection (One / multiple)	
		3	Forbidden	
		4	Remote controller switch 2(Master / Slave)	
		5	Forbidden	
		6	Forbidden	
	SW 2	1	Cooling / Heat pump	
		2	Auto change over validity / invalidity	
		3	Back ground light validity / invalidity	* Simple remote controller only
		4	Maintenance switch	
		5	Forbidden	
		6	Battery backup switch	* Wired remote controller only

2-1-5 CENTRAL REMOTE CONTROLLER CIRCUIT BOARD

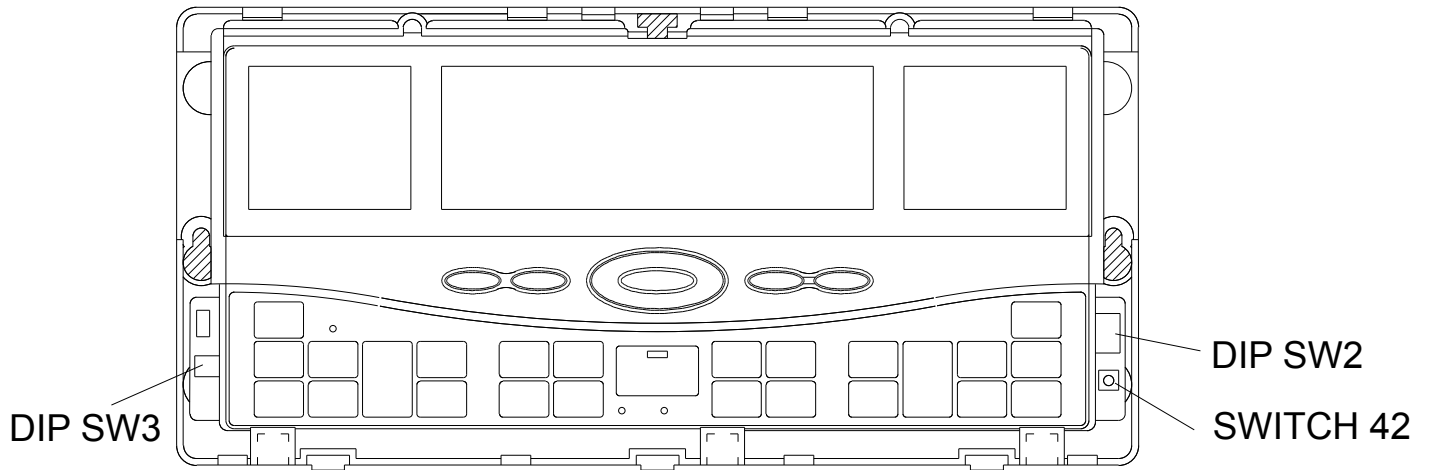

Central remote controller			
DIP-SW	SW 2	1	External input validity / invalidity
		2	External input select edge / pulse
		3	Filter sign indication ON / OFF
		4	°C / °F switch
		5	RC operation prohibit function validity/invalidity
		6	Forbidden
		7	Forbidden
		8	SRAM battery ON / OFF
	SW 3	1	Forbidden
		2	Forbidden
		3	Forbidden
		4	Forbidden
	SW 42		Initial setting

2-1-6 NETWORK CONVERTORS' CIRCUIT BOARD

(1) NETWORK CONVERTOR (UTR-YSSA)

Network Convertor (UTR-YSSA)			
DIP SW	SW 103	1	Remote controller type
		2	
		3	
		4	Number of connected indoor units
		5	
		6	
		7	
		8	
	SW 107	1	Forbidden
		2	Wired remote controller validity / invalidity
	SW 108	1	External input validity / invalidity
		2	External input select edge / pulse
SW 109	1	Auto changeover validity / invalidity * Set to OFF for duct type indoor unit	
	2	Auto restart validity / invalidity	
ROTARY SW	SW 110	Refrigerant circuit address 1	
	SW 111	Refrigerant circuit address 2	

■ SWITCH POSITION

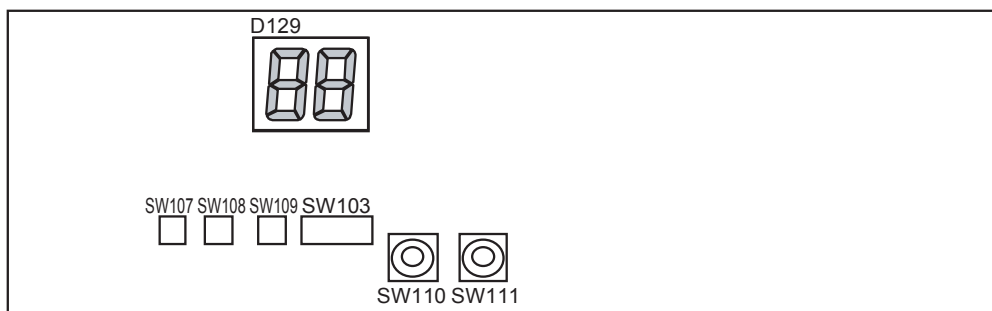

(2) NETWORK CONVERTOR (UTR-YLLA)

(Switch)

Switch No.	Type	Contents
SW1	Push switch	Service Pin SW (VRF side)
SW2	Push switch	Service Pin SW (Lon works side)
SW3	Push switch	Selection of setting mode
SW4	Push switch	Confirmation of setting
SW5	Rotaly switch (0-15)	Setting up the value at the each setting mode (D25-D22)
SW6	Rotaly switch (0-15)	Setting up the value at the each setting mode (D21-D18)
SW7	Push switch	CPU Reset

(LED)

LED No.	Contents
D9	Light up when SW1 is pressed (Neuron ID Transmission)
D14	Light up when SW2 is pressed (Neuron ID Transmission)
D25-D18	Indicates the setting value specified with SW5 and SW6
D29-D26	Indicates the setting mode selected with SW3

■ SWITCH AND LED POSITION

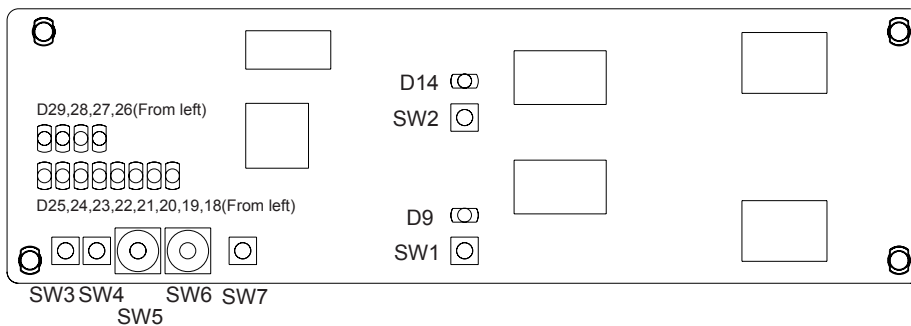

2-2 MICROPROCESSOR FUNCTION LIST

2-2-1 INDOOR UNIT

INDOOR UNIT TYPE		Large Ceiling	Universal	Compact Cassette	Thin Cassette	Large Cassette	Compact Duct	Low Static Pressure Duct	High Static Pressure Duct
CAPACITY (BTU/h)	60,000								○
	54,000	○				○			
	45,000	○				○		○	○
	36,000	○				○		○	○
	30,000	○			○			○	
	24,000 (25,000)		○ 24		○ 25			○ 25	
	20,000				○				
	18,000		○	○			○		
	14,000		○	○			○		
	12,000		○	○			○		
	9,000			○			○		
7,000			○			○			
CN1	AC IN	○	○	○	○	○	○	○	○
CN2	TH. FUSE	○	○	○	○	○	○	○	○
CN3	FAN CAPA	○	○	○	○	○	○	○	○
CN4	FAN MOTOR	○	○	○	○	○	○	○	○
CN5	D. PUMP	○	○	○	○	○	○	○	○
CN6	S. VALVE	○	○	○	○	○	○	○	○
CN10	SP-M (U,D)	○	○	○	○	○	—	—	—
CN11	SP-M (R,L)	—	—	—	—	—	—	—	—
CN12	HEATER	○	○	○	○	○	○	○	○
CN13	DISPLAY	○	○	○	○	○	○	○	○
CN14	E.E. VALVE	○	○	○	○	○	○	○	○
CN15	FLOAT SW	○	○	○	○	○	○	○	○
CN16	MOTOR F. BACK	○	—	—	○	—	—	—	—
CN17	REMOCON	○	○	○	○	○	○	○	○
CN18	TEST	○	○	○	○	○	○	○	○
CN19	R. TH	○	○	○	○	○	○	○	○
CN20	P. TH	○	○	○	○	○	○	○	○
CN21	S. TH	○	○	○	○	○	○	○	○
CN22	EX. OUT1	○	○	○	○	○	○	○	○
CN23	EX. OUT2	○	○	○	○	○	○	○	○
CN24	EX. OUT3	○	○	○	○	○	○	○	○
CN25	FLASH	○	○	○	○	○	○	○	○
CN26	COMMUNICATION-PWB	○	○	○	○	○	○	○	○
CN27	EX. IN	○	○	○	○	○	○	○	○
CN101	NETWORK	○	○	○	○	○	○	○	○
CN201	COMMUNICATION	○	○	○	○	○	○	○	○
SW1	FUNCTION 1	○	○	○	○	○	○	○	○
SW2	FUNCTION 2	○	○	○	○	○	○	○	○
SW3	FUNCTION 3	○	○	○	○	○	○	○	○
SW4	FUNCTION 4	○	○	○	○	○	○	○	○
SW5	FUNCTION 5	○	○	○	○	○	○	○	○
SW6	INDOOR UNIT ADDRESS 1	○	○	○	○	○	○	○	○
SW7	FORBIDDEN	○	○	○	○	○	○	○	○
SW8	REFRIGERANT ADDRESS 1	○	○	○	○	○	○	○	○
SW9	REFRIGERANT ADDRESS 2	○	○	○	○	○	○	○	○
SW10	REMOTE CONTROLLER ADDRESS	○	○	○	○	○	○	○	○

INDOOR UNIT TYPE			Wall Mounted	Ceiling Wall
CAPACITY (BTU/h)		30,000	○	○
		24,000	○	○
		18,000	○	○
		14,000		○
	CN1	TH. FUSE	○	○
	CN2	FAN MOTOR	○	—
	CN3	FAN MOTOR	—	○
	CN4	D. PUMP	○	○
	CN5	S. VALVE	○	○
	CN6	DIFFUSER/SP-M(U,D)	○	○
	CN7	SP-M(L/R)	○	○
	CN8	DISPLAY-1	○	○
	CN9	DISPLAY-2	○	○
	CN10	F. BACK	—	—
	CN11	TEST	○	○
	CN12	E.E.VALVE	○	○
	CN13	REMOCON	○	○
	CN14	FLOAT	○	○
	CN15	NETWORK	○	○
	CN16	R.-TH	○	○
	CN17	P-TH	○	○
	CN18	S-TH	○	○
	CN19	FLASH	○	○
	CN20	HEATER	○	○
	CN21	EX. IN	○	○
	CN22	EX. OUT1	○	○
	CN23	EX. OUT2	○	○
	CN24	EX. OUT3	○	○
	CN25	COMMUNICATION-PWB	○	○
	CN26	COMMUNICATION	○	○
	SW1	FUNCTION 1	○	○
	SW2	FUNCTION 2	○	○
	SW3	FUNCTION 3	○	○
	SW4	FUNCTION 4	○	○
	SW5	FUNCTION 5	○	○
	SW6	INDOOR UNIT ADDRESS 1	○	○
	SW7	FORBIDDEN	○	○
	SW8	REFRIGERANT ADDRESS 1	○	○
	SW9	REFRIGERANT ADDRESS 2	○	○
	SW10	REMOTE CONTROLLER ADDRESS	○	○

INDOOR UNIT TYPE		Compact Wall Mounted
CAPACITY (BTU/h)	14,000	<input type="radio"/>
	12,000	<input type="radio"/>
	9,000	<input type="radio"/>
	7,000	<input type="radio"/>
CN1	POWER-PWB	<input type="radio"/>
CN2	FAN F. BACK	<input type="radio"/>
CN3	E. E. VALVE	<input type="radio"/>
CN4	SP MOTOT(U,D)	<input type="radio"/>
CN5	DISPLAY	<input type="radio"/>
CN6	ROOM TH.	<input type="radio"/>
CN7	PIPE TH.	<input type="radio"/>
CN8	TEST	<input type="radio"/>
CN9	FLASH	<input type="radio"/>
CN10	EX. IN	<input type="radio"/>
CN11	EX. OUT	<input type="radio"/>
CN12	COMMUNICATION-PWB	<input type="radio"/>
CN101	MAIN-PWB	<input type="radio"/>
CN102	FAN MOTOR	<input type="radio"/>
CN103	TRANS-P	<input type="radio"/>
CN104	TRANS-S	<input type="radio"/>
CN105	TH. FUSE	<input type="radio"/>
CN106	S. VALVE	<input type="radio"/>
CN107	NETWORK	<input type="radio"/>
CN108	COMMUNICATION	<input type="radio"/>
W101-102	POWER SUPPLY	<input type="radio"/>
W103-104	FAN CAPACITOR	<input type="radio"/>
SW1	FUNCTION	<input type="radio"/>
SW2	FUNCTION & INDOOR UNIT ADDRESS	<input type="radio"/>
SW3	REFRIGERANT CIRCUIT ADDRESS	<input type="radio"/>
SW4	INDOOR UNIT ADDRESS	<input type="radio"/>
SW5	REFRIGERANT CIRCUIT ADDRESS	<input type="radio"/>
JM1	WIRELESS REMOTE CONTROLLER CUSTOM	<input type="radio"/>
JM2	WIRELESS REMOTE CONTROLLER CUSTOM	<input type="radio"/>

2-2-2 OUTDOOR UNIT

OUTDOOR UNIT TYPE		AOY90MPAMF
CN1	AC IN	○
CN2	NET	○
CN3	FAN.1	○
CN4	FAN.2	○
CN5	BASE HEATER	○
CN6	CRANK CASE HEATER	○
CN7	S.V.1	○
CN8	S.V.2	○
CN9	S.V.3	○
CN10	S.V.4	○
CN11	S.V.5	○
CN12	S.V.6	○
CN13	S.V.7	○
CN14	S.V.8	○
CN18	4WV.2	○
CN19	4WV.3	○
CN20	4WV.4	○
CN22	TERMINATOR	○
CN24	COMP.1	○
CN25	COMP.2	○
CN26	COMP.3	○
CN27	TH.1	○
CN28	FLASH W/R S	○
CN29	E.E.V.1	○
CN30	E.E.V.2	○
CN31	E.E.V.3	○
CN33	P.SEN-M	○
CN34	P.SEN-H	○
CN35	TEST	○
CN42	P.SW-H	○
CN44	FLASH W/R M	○
CN45	TH.2	○
CN48	EXT.OUT PUT	○
CN51	COMMUNICATION PWB.	○
SW1	FUNCTION 1	○
SW2	FUNCTION 2	○
SW3	FUNCTION 3	○
SW4	FUNCTION 4	○
SW5	FUNCTION 5	○
SW6	FUNCTION 6	○
SW7	FUNCTION 7	○
SW8	REFRIGERANT ADDRESS 1	○
SW9	REFRIGERANT ADDRESS 2	○

2-3 FUNCTION AND SETTING OF EACH SWITCH

2-3-1 INDOOR UNIT (EXCEPT FOR COMPACT WALL MOUNTED TYPE)

■ DIP SWITCH SETTING

1. SW1 setting

1-1 Ceiling height setting

CEILING HEIGHT SETTING (CASSETTE TYPE) (◆ . . . Factory setting)

	SW1-1	SW1-2	suitable ceiling height (m)
◆ Standard	OFF	OFF	2.5~3
High ceiling 1	ON	OFF	3~3.5
High ceiling 2	OFF	ON	more than 3.5
Low ceiling	ON	ON	less than 2.5

This function is validity only cassette type

1-2 Room temperature correct coefficient of heating.

Decide the heating temperature correct coefficient value of heating.

HEATING TEMPERATURE CORRECTION (◆ . . . Factory setting)

SW1-3	SW1-4	Coefficient value
◆ OFF	OFF	+ 4 deg
ON	OFF	+ 8 deg
OFF	ON	0 deg
ON	ON	+ 12 deg

2. SW2 setting

2-1 Room temperature correct coefficient of cooling.

Decide the cooling temperature correct coefficient value of cooling.

COOLING TEMPERATURE CORRECTION (◆ . . . Factory setting)

SW2-1	Coefficient value
◆ OFF	0 deg
ON	+ 2 deg

2-2 Dip SW 2-2 setting forbidden

(◆ . . . Factory setting)

◆ SW2-2	OFF
---------	-----

2-3 Filter check validity / invalidity.

Filter check is set with Dip SW 2-3

FILTER CLEANING FUNCTION (◆ . . . Factory setting)

SW2-3	Filter check
◆ OFF	Invalidity
ON	Validity

2-4 Auto restart validity / invalidity.

Control the auto restart function by turning this switch ON/OFF.

AUTO RESTART SETTING (◆ . . . Factory setting)

SW2-4	Auto restart
◆ OFF	Invalidity
ON	Validity

3. SW3 setting (Never change at the site)

3-1 Indoor unit fan speed switch

This switch can select fan speed corresponding to each model.

* Large ceiling type

	AB30	AB36	AB45	AB54
SW3-1	OFF	OFF	OFF	OFF
SW3-2	OFF	ON	OFF	ON
SW3-3	OFF	OFF	ON	ON

* Cassette type

	AU54	AU45	AU36	AU30	AU25	AU20
SW3-1	OFF	ON	OFF	OFF	OFF	ON
SW3-2	OFF	OFF	ON	OFF	ON	ON
SW3-3	OFF	OFF	OFF	ON	ON	ON

* Wall mounted type

	AS18	AS24	AS30
SW3-1	OFF	OFF	ON
SW3-2	OFF	ON	ON
SW3-3	ON	ON	ON

* Ceiling wall type

	AW7	AW9	AW12	AW14	AW18	AW24	AW30
SW3-1	OFF	ON	OFF	ON	OFF	OFF	ON
SW3-2	OFF	OFF	ON	ON	OFF	ON	ON
SW3-3	OFF	OFF	OFF	OFF	ON	ON	ON

* Other model (Default)

SW3-1	OFF
SW3-2	OFF
SW3-3	OFF

3-2 DIP SW 3-4 setting

This switch is used to select the format of external input command as shown in the table below.

(◆ . . . Factory setting)

SW3-4	External input select
◆ OFF	Edge
ON	Pulse

4. SW4 setting (Never change at the site)

Indoor unit model code.

This switch for changing the model code information of indoor unit PCB.

INDOOR UNIT MODEL CODE

Capacity Type	60	54	45	36	30	25(24)	20	18	14	12	9	7
SW4-1	ON	OFF	ON	OFF	ON	OFF	ON	OFF	ON	OFF	ON	OFF
SW4-2	ON	ON	OFF	OFF	ON	ON	OFF	OFF	ON	ON	OFF	OFF
SW4-3	OFF	OFF	OFF	OFF	ON	ON	ON	ON	OFF	OFF	OFF	OFF
SW4-4	ON	ON	ON	ON	OFF	OFF	OFF	OFF	OFF	OFF	OFF	OFF

5. SW5 setting

5-1 Wireless remote controller custom code switch

Decid the custom code and restrict the type of infrared control signal, in order to prevent mixing of multiple indoor unit signals.

Remote controller

Remote controller custom code switch

(◆ . . . Factory setting)

SW5-1	SW5-2	Custom code
◆ OFF	OFF	Type A
ON	OFF	Type B
OFF	ON	Type C
ON	ON	Type D

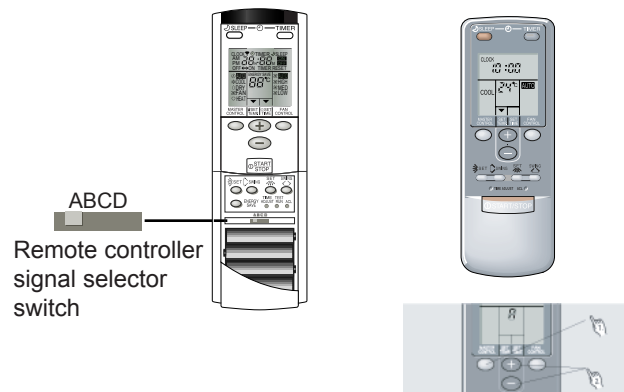

5-2 Frost prevention temperature shift switch

Set the frost prevention temperature for indoor unit.

Frost prevention temperature shift switch

(◆ . . . Factory setting)

SW5-3	Frost prevention temperature
◆ OFF	Normal
ON	High

1. Press the MASTER CONTROL button for more than five seconds to start the code change.
2. Press the (+) or (-) button to select the desired code.
3. Press the MASTER CONTROL button again to end the code change.

5-3 Draft prevention setting switch (only for cassette type)

Set the flap angle of cassette type unit.

Draft prevention switch

(◆ . . . Factory setting)

SW5-4	flap angle
◆ OFF	Normal position
ON	Draft prevention position

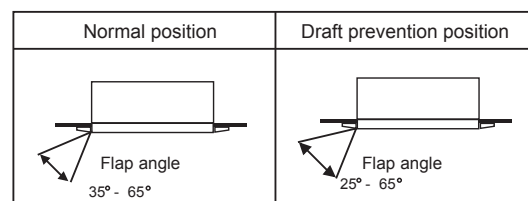

An air flow direction, by moving the flap angle horizontally, It can prevent that a cold wind directly hits.

*If air conditioning cooling operation is performed in long time and a humid place, there is a possibility that waterdrop may hang down from a blow-off mouth.

■ ROTARY SWITCH SETTING

1.SW6 setting

Indoor unit address switch

Sets the indoor unit addresses.

INDOOR UNIT ADDRESS SWITCH (Factory setting : 0)

Rotary SW	Description	Remarks
6	Indoor unit address SW	Indoor unit address (0~15)

2.SW7 setting forbidden

Rotary SW7	0
------------	---

3.SW8,9 setting

Refrigerant circuit address switch

Sets the refrigerant circuit.

REFRIGERANT CIRCUIT ADDRESS SWITCH (Factory setting SW 8: 0 SW 9: 0)

Rotary SW	Description	Remarks
8	Refrigerant circuit address 1	Refrigerant circuit address (the first digit)
9	Refrigerant circuit address 2	Refrigerant circuit address (the second digit)

4.SW10 setting

Remote controller address switch

When the indoor unit is wired by remote controller group, to identify the indoor unit in the remote controller group, the number (remote controller address) in the remote controller group is set. Set the remote controller address in the 0.1.2,~,15 order (Blank is not allowed)

REMOTE CONTROLLER ADDRESS SWITCH (Factory setting : 0)

Rotary SW	Description	Remarks
10	Remote controller address SW	Remote controller address

■ EXTERNAL INPUT AND OUTPUT

Connector	Indoor unit type	Input	Output	Remarks
CN21	Wall mounted / Ceiling wall types	CONTROL INPUT (OPERATION / STOP)	—	See 2-4-1 for details
CN27	Other types			
CN22	All types	—	OPERATION DISPLAY (DC12V)	
CN23			ERROR DISPLAY (DC12V)	
CN24			INDOOR UNIT FAN STATUS DISPLY(DC12V)	

2-3-2 INDOOR UNIT (COMPACT WALL MOUNTED TYPE)

■ DIP SWITCH SETTING

1. SW1 setting (Never change at the site)

1-1 Fan speed setting switch

The fan speed corresponding to each model is set with the switch.

	AS7	AS9	AS12	AS14
SW1-1	OFF	ON	OFF	ON
SW1-2	OFF	OFF	ON	ON

1-2 Model code setting switch

The model code information corresponding to each model is provided with the switch.

	AS7	AS9	AS12	AS14
SW1-3	OFF	ON	OFF	ON
SW1-4	OFF	OFF	ON	ON

2. SW2 setting

2-1 Dip SW 2-1,2-2 setting forbidden

(◆ . . . Factory setting)

◆ SW2-1	OFF
◆ SW2-2	OFF

2-2 Auto restart validity / invalidity.

The auto restart function becomes validity by changing the switch position from OFF to ON.

AUTO RESTART SETTING (◆ . . . Factory setting)

SW2-3	Auto restart
◆ OFF	Invalidity
ON	Validity

2-3 DIP SW 2-4 setting forbidden.

(◆ . . . Factory setting)

◆ SW2-4	OFF
---------	-----

3. SW3 setting

3-1 Refrigerant circuit address switch

By combined with Rotary SW5 , the refrigerant circuit address (0-99) can be set.
Please see "6-2 ADDRESS SETTING" for refrigerant address conversion table.

(◆ . . . Factory setting)

Refrigerant circuit address	SW3-1	SW3-2	SW3-3	Remarks
◆ 0 - 15	OFF	OFF	OFF	About Rotary SW5, see next page
16 - 31	ON	OFF	OFF	
32 - 47	OFF	ON	OFF	
48 - 63	ON	ON	OFF	
64 - 79	OFF	OFF	ON	
80 - 95	ON	OFF	ON	
96 - 99	OFF	ON	ON	

3-2 DIP SW 3-4 setting forbidden.

(◆ . . . Factory setting)

◆ SW3-4	OFF
---------	-----

■ ROTARY SWITCH SETTING

1.SW4 setting

Indoor unit address switch

Set the indoor unit addresses.

INDOOR UNIT ADDRESS SWITCH (Factory setting : 0)

Rotary SW	Description	Remarks
4	Indoor unit address SW	Indoor unit address (0~15)

2.SW5 setting

Refrigerant circuit address switch

By combined with DIP switch 3-1,3-2 and 3-3,the refrigerant circuit address(0 - 99)can be set. Please see "5-3-3 ADDRESS SETTING" for the refrigerant address conversion table.

REFRIGERANT CIRCUIT ADDRESS SWITCH (Factory setting SW 5: 0)

Rotary SW	Description	Remarks
5	Refrigerant circuit address SW	About DIP switch 3-1,3-2 and 3-3 see previous page

■ JUMPER WIRE

Wireless remote controller custom code switch

Limit the type of infrared control signal which the indoor unit is controlled,in order to prevent misoperation of the unit due to the signal from other wireless remote controller.

Remote controller custom code switch

(◆ . . . Factory setting)

	JM 1	JM 2	Custom code
◆	Connect	Connect	Type A
	Disconnect	Connect	Type B
	Connect	Disconnect	Type C
	Disconnect	Disconnect	Type D

ABCD
Remote controller signal selector switch

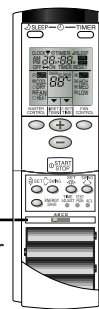

Remote controller



1. Press the MASTER CONTROL button for more than five seconds to start the code change.
2. Press the (+) or (-) button to select the desired code.
3. Press the MASTER CONTROL button again to end the code change.

■ EXTERNAL INPUT AND OUTPUT

Connector	Input or Output	Remarks
CN10	Control Input (Operation / Stop)	See 2-4-2 for details.
CN11	Operation Display (DC12V)	

2-3-3 OUTDOOR UNIT

• DIP SWITCH SETTING

1. SW1 setting

1-1 Test run

By setting DIP SW1-1 and SW1-2 on control PC board of outdoor unit, cooling test run or heating test run for all the indoor units in the same refrigerant system can be performed.

SELECTOR SWITCH FOR TEST RUN AND NORMAL OPERATION (◆ . . . Factory setting)

SW1-2	SW1-1	Test Run	Remarks
◆ OFF	OFF	Normal operation	
OFF	ON	Cooling test run	[OFF,OFF]→[OFF,ON] and be kept at [OFF,ON] position for more than 1 min.
ON	OFF	Heating test run	[OFF,OFF]→[ON,OFF] and be kept at [OFF,ON] position for more than 1 min.
ON	ON	Normal operation	

1-2 Pump down operation

Pump down operation is set with SW1-3

PUMP DOWN OPERATION (◆ . . . Factory setting)

SW1-3	Pump down operation	Remarks
◆ OFF	Release	
ON	Operate	OFF→ON and be kept at ON position for more than 30 sec.

1-3 Forced defrost operation

FORCED DEFROST OPERATION (◆ . . . Factory setting)

SW1-4	Forced defrost	Remarks
◆ OFF	Release	
ON	Operate	OFF→ON and be kept at ON position for more than 10 sec.

2. SW2 setting

2-1 Silent operation mode (cooling mode only)

Noise level can be reduced using silent operation mode when the outdoor temperature decreases below 30°C.

SILENT OPERATION MODE (◆ . . . Factory setting)

SW 2-1	Silent operation mode
◆ OFF	Release
ON	Operate

2-2 Snow falling protection fan mode

When snowing, to prevent the unit from being covered with snow, the outdoor fan is periodically operated by this switch even when the compressor is stopped.

SNOW FALLING PROTECTION SW (◆ . . . Factory setting)

SW2-2	Snow falling protection fan mode
◆ OFF	Release
ON	Operate

2-3 Expansion valve initialization

This switch initializes the number of pulses of the expansion valve when the outdoor unit is stopped.

ELECTRONIC EXPANSION VALVE INITIALIZATION (◆ . . . Factory setting)

SW2-3	Initialization
◆ OFF	Release
ON	Operate

2-4 Forced oil recovery operation.

Oil recovery is started manually by DIP SW 2-4 on the PCB.

FORCED OIL RECOVERY (◆ . . . Factory setting)

SW2-4	Forced oil recovery	Remarks
◆ OFF	Release	
ON	Operate	OFF → ON and be kept at ON position for more than 10 seconds

3. SW3 setting

Dip SW3-1,3-2,3-3 and SW3-4 setting forbidden

SW3-1	OFF
SW3-2	OFF
SW3-3	OFF
SW3-4	OFF

4. SW4 setting

4-1 Defrost temperature setting SW

The threshold temperature for starting a defrosting operation can be selected by setting up the switches.

DEFROST TEMPERATURE (◆ . . . Factory setting)

SW4-2	SW4-1	Temperature
OFF	OFF	Standard
OFF	ON	Low
ON	OFF	High
ON	ON	Lower

4-2 Dip SW4-3 and SW4-4 setting forbidden.

SW4-3	OFF
SW4-4	OFF

5. SW5 setting

5-1 Dip SW 5-1, SW5-2 and SW5-4 setting forbidden

5-2 Base heater validity/invalidity

This switch sets the output of the base heater (CN5) on the PCB.

BASE HEATER SWITCH (◆ . . . Factory setting)

SW5-3	Base heater
◆ OFF	Invalidity
ON	validity

The base heater output turns ON at an outside temperature of 2°C or less during heating operation.

Base heater : 220-240V AC , 35W , field supplied.

6. SW6 setting

DIP SW 6-1,SW6-2,SW6-3 and SW6-4 setting forbidden

SW6-1	OFF
SW6-2	OFF
SW6-3	OFF
SW6-4	OFF

7. SW7 setting

7-1 System type switches

SYSTEM TYPE SWITCHES (◆ . . . Factory setting)

SW7-2	SW7-1	System type
OFF	OFF	Forbidden
OFF	ON	Forbidden
◆ ON	OFF	Heat recovery
ON	ON	Forbidden

7-2 Dip SW 7-3 and SW 7-4 setting forbidden

SW7-3	OFF
SW7-4	OFF

• ROTARY SWITCH SETTING

SW8,9 setting

Rotary SW	Description	Remarks
8	Refrigerant circuit address 1	Refrigerant circuit address (the first digit)
9	Refrigerant circuit address 2	Refrigerant circuit address (the second digit)

• EXTERNAL OUTPUT

Connector	Output
CN48	Error Display (DC12V)

2-3-4 WIRED , SIMPLE REMOTE CONTROLLER

• DIP SWITCH SETTING

1. SW1 setting

1-1 Remote controller switch 1

This is used to set up the terminated resistance of the wired remote controller.

When 1 remote controller is connected to remote controller group, set this ON all the time.

When 2 remote controllers are connected to remote controller group, set the Master one OFF, and set the Slave one ON.

REMOTE CONTROLLER SWITCH 1 (◆ . . . Factory setting)

SW1-1	Terminator setting
OFF	Not terminated
◆ ON	Terminated

1-2 Number of indoor unit connection (One/Multiple)

This is switched according to the number of connected indoor units.

NUMBER OF INDOOR UNIT CONNECTION(◆ . . . Factory setting)

SW1-2	Number of indoor unit
◆ OFF	One unit connection
ON	Multiple unit connection

1-3 DIP SW1-3 setting forbidden

SW 1-3	OFF
--------	-----

1-4 Remote controller switch 2

If it is used to set up Master/Slave setting of wired remote control.

When 1 remote control is connected to 1 remote control group, always set the Master OFF.

When 2 remote controls are connected to remote control group, set one side to Master, and the other side to Slave.

REMOTE CONTROLLER SWITCH 2 (◆ . . . Factory setting)

SW1-4	Setting for Master/Slave
◆ OFF	Master
ON	Slave

1-5 DIP SW 1-5 and SW 1-6 setting forbidden.

SW 1-5	OFF
SW 1-6	OFF

2. SW2 setting

2-1 Cooling only / heat pump

Switching cooling only / heat pump.

COOLING ONLY / HEAT PUMP SWITCH (◆ . . . Factory setting)

	SW2-1	Operation system
◆	OFF	Heat pump/Heat recovery
	ON	Cooling only

2-2 Auto change over validity/invalidity

Selecting auto change over validity/invalidity.

Never turn it on in the case of Heat pump type.

AUTO CHANGE OVER (◆ . . . Factory setting)

	SW2-2	Auto change over
◆	OFF	Invalidity
	ON	Validity

2-3 Back ground Light validity (simple remote controller only)

Selecting to use internal background light validity/invalidity.

The background light can turn on during indoor unit operation.

(◆ . . . Factory setting)

	SW 2-3	Background light
◆	OFF	Invalidity
	ON	Validity

Never turn it ON in the case of wired remote controller.

2-4 Maintenance switch

Used to indicate of the refrigerant system, indoor unit address.

MAINTENANCE SWITCH (◆ . . . Factory setting)

	SW2-4	Mode
◆	OFF	Normal mode
	ON	Maintenance mode

2-5 DIP SW 2-5 setting forbidden.

SW 2-5	OFF
--------	-----

2-6 Battery backup switch (Wired remote controller only)

When installing, turn the SW2-6 ON.

BATTERY BACKUP SWITCH (◆ . . . Factory setting)

	SW2-6	Battery backup
◆	OFF	Invalidity
	ON	Validity

Never turn it ON in the case of simple remote controller.

2-3-5 CENTRAL REMOTE CONTROLLER

1. DIP-SW2 SETTING

1-1 DIP SW2-1 setting .

For validity / invalidity the external input function.

(◆ . . . Factory setting)

SW 2-1	External input function
OFF	Invalidity
ON	Validity

1-2 DIP SW2-2 setting .

Select the external input command function.

(◆ . . . Factory setting)

SW 2-2	External input select
OFF	Edge
ON	Pulse

(Refer to 2-4-4 about external input & output)

1-3 DIP SW2-3 setting.

Filter check sign indication or not when filter check come from indoor unit.

(◆ . . . Factory setting)

SW2-3	Filter check sign indication
OFF	Non-Display
ON	Display

1-4 DIP SW2-4 setting.

°C / °F switch

Temperature display is centigrate(°C) / Fahrenheit(°F)

(◆ . . . Factory setting)

SW2-4	°C / °F
OFF	°C
ON	°F

1-5 DIP SW2-5 setting

For validity / invalidity the wired and wireless remote controller operation prohibit function.

(◆ . . . Factory setting)

SW2-5	RC operation prohibit function
OFF	Validity
ON	Invalidity

1-6 DIP SW2-6 and 2-7 setting forbidden.

SW 2-6	OFF
SW 2-7	OFF

1-7 DIP SW2-8 setting.

SRAM Battery ON / OFF

When installing the control remote controller, this switch must be set to ON.

(factory setting:OFF)

(◆ . . . Factory setting)

SW2-8	SRAM Battery
◆ OFF	OFF
ON	ON

At the time of shipment, the battery is turned off to avoid electricity consumption.
Be sure to set this switch to ON.

1-8 SW42 Initial setting button

This switch is used when initializing the central remote controller.

2-3-6 NETWORK CONVERTOR

(1) Network convertor (UTR-YSSA)

1. Dip SW103 (1, 2, 3, 4) setting

Set Dip SW103 (1, 2, 3, 4) according to indoor unit type and remote controller (packaged together with the unit) type. You can also set DIP-SW103 (1, 2, 3, 4) using the remote controller number that is shown on the rear surface of the remote controller.

Instead of using the remote controller that was packaged together with the unit, a VRF type remote controller must be used to connected to network.

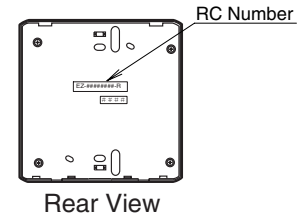

Indoor unit model type and remote controller type

(◆ . . . •Factory setting)

DIP-SW103				Indoor unit type	RC type	RC number
1	2	3	4			
◆ OFF	OFF	OFF	OFF	Heat pump of single spilt type	With weekly timer	EZ-099DHSE-*,EZ-000DHSE-*,EZ-0001HSE-*,EZ-000GHSE-*,EZ-00004HSE-*,EZ-00005HSE-*,EZ-0015HSE-*,EZ-0019HSE-*
OFF	OFF	OFF	ON	Heat pump of big multi type	With weekly timer	EZ-0994HSE-*,EZ-000EHSE-*
OFF	OFF	ON	OFF	Heat pump of single spilt type	Without weekly timer	EZ-09503HSE-*,EZ-0950DHSE-*
ON	OFF	OFF	OFF	Cooling only of single spilt type	With weekly timer	EZ-099CWSE-*,EZ-000AWSE-*,EZ-0001WSE-*,EZ-000FWSE-*,EZ-0012WSE-*
ON	OFF	OFF	ON	Cooling only of big multi type	With weekly timer	EZ-09906WSE-*,EZ-000FWSE-*
ON	OFF	ON	OFF	Cooling only of single spilt type	Without weekly timer	EZ-095YWSE-*
ON	ON	OFF	OFF	Wall mounted with wired RC	Without weekly timer	EZ-098VWSE-*

Asterisks (*) are used in place of variable characters.

2. DIP- SW103 (5, 6, 7, 8) setting

Set the DIP-SW 103 (5, 6, 7, 8) according to number of the connected indoor units.

Number of the connected indoor units

(◆ . . . •Factory setting)

DIP-SW 103				Number of connected the Indoor unit
5	6	7	8	
◆ OFF	OFF	OFF	OFF	1
OFF	OFF	OFF	ON	2
OFF	OFF	ON	OFF	3
OFF	OFF	ON	ON	4
OFF	ON	OFF	OFF	5
OFF	ON	OFF	ON	6

DIP-SW 103				Number of connected the Indoor unit
5	6	7	8	
OFF	ON	ON	OFF	7
OFF	ON	ON	ON	8
ON	OFF	OFF	OFF	9
ON	OFF	OFF	ON	10
ON	OFF	ON	OFF	11
ON	OFF	ON	ON	12

DIP-SW 103				Number of connected the Indoor unit
5	6	7	8	
ON	ON	OFF	OFF	13
ON	ON	OFF	ON	14
ON	ON	ON	OFF	15
ON	ON	ON	ON	16

3. DIP SW 107 Setting

3-1 DIP SW 107-1 setting forbidden

(◆ . . . •Factory setting)

◆ SW 107-1	OFF
------------	-----

3-2 Wired remote controller validity / invalidity

Select the wired remote controller validity / invalidity

Wired remote controller (◆ . . . •Factory setting)

SW 107-2	Wired remote controller
◆ OFF	Invalidity
ON	validity

4. DIP SW 108 setting

4-1 External input validity / invalidity

Select the external input function validity / invalidity

(◆ . . . Factory setting)

SW 108-1	External input function
◆ OFF	Invalidity
ON	validity

4-2 External input command type

Select the external input command type

(◆ . . . Factory setting)

SW 108-2	External input command type
◆ OFF	Edge
ON	Pulse

5. DIP SW109 setting

5-1 Auto changeover validity / invalidity

Select auto changeover function validity / invalidity

(◆ . . . Factory setting)

SW 109-1	Auto changeover function
◆ OFF	Invalidity
ON	validity

5-2 Auto restart validity / invalidity

Select auto restart function validity / invalidity

(◆ . . . Factory setting)

SW 109-2	Auto restart function
◆ OFF	Invalidity
ON	validity

2-4 EXTERNAL INPUT & OUTPUT

2-4-1 INDOOR UNIT (EXCEPT FOR COMPACT WALL MOUNTED TYPE

(1) Control input (Operation/Stop)

Indoor unit can be operated or stopped by using indoor unit PCB
CN 21 (Wall mounted type / ceiling wall type) or CN27 (other types)

① Input select

Dip SW3-4	Input select
OFF	Edge
ON	Pulse

② In the case of "Edge" input

CONNECTOR	INPUT SIGNAL	COMMAND
Ch1 of CN21 ^{*1)} (RED) or CN27 ^{*2)} (RED)	OFF → ON	Operation
	ON → OFF	Stop

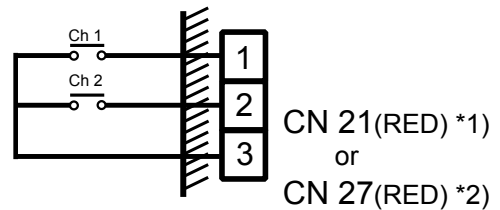

*1) For Wall mounted type / Ceiling wall type.
*2) For other types

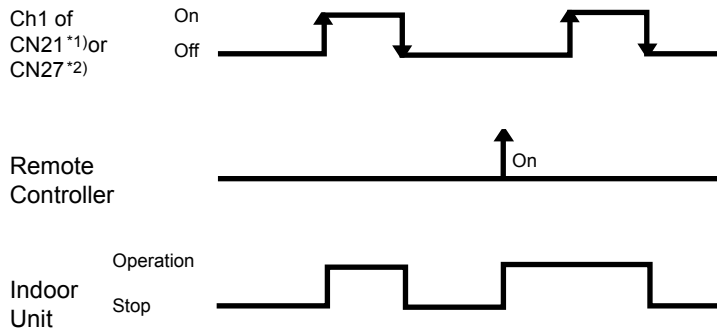

NOTE

1. The last command has priority.
2. The indoor units within the same remote controller group operates in the same mode.
3. The wire connection shall be separate from the power cable line.

③ In the case of "pulse" input

CONNECTOR	INPUT SIGNAL	COMMAND
CN21 ^{*1)} (RED) or CN27 ^{*2)} (RED)	Ch1	OFF → ON
	Ch2	OFF → ON

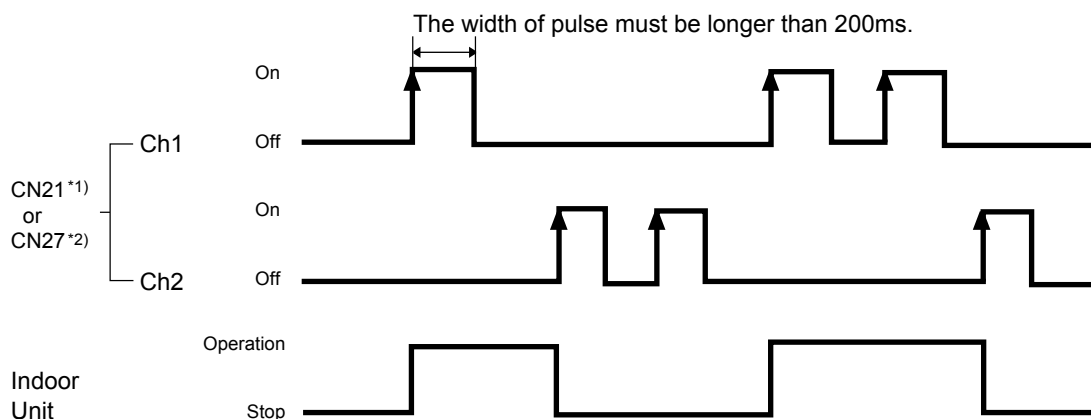

(2) Output

CONNECTOR	OUT VOLTAGE	STATUS
CN22	12V	Operation
	0V	Stop
CN23	12V	Error
	0V	Normal
CN24	12V	Fan run
	0V	Fan stop

① Operation display

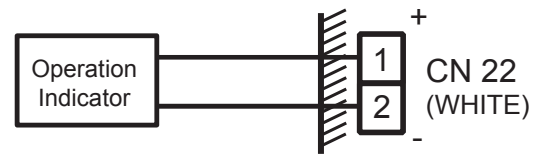
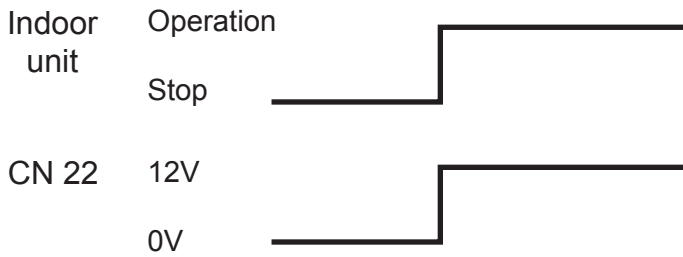

② Error display

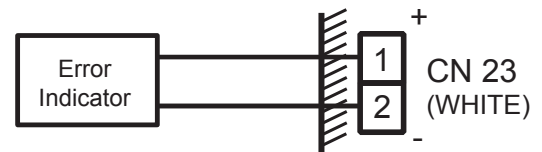
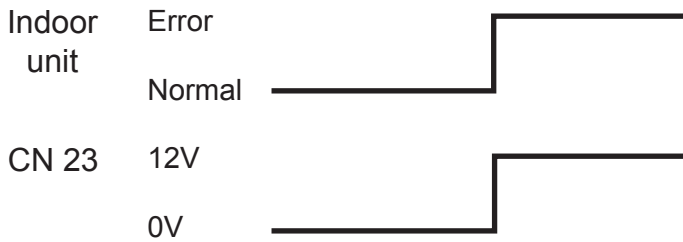

③ Inter locking output with indoor unit fan

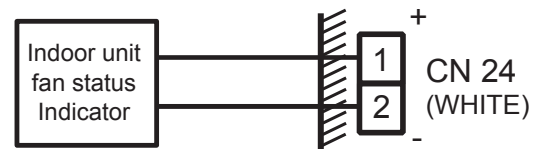
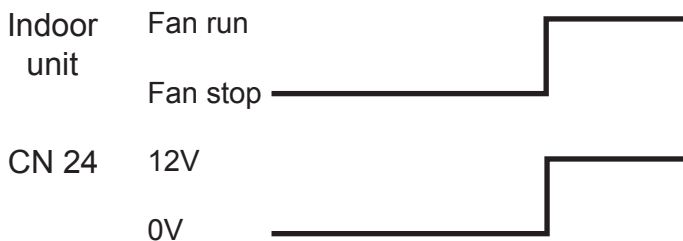

EX) Used for inter lock energize for exhaust fan.

(3) Parts

Following cord (service parts) is required. Please use the parts number shown below to order the cord from your sales representative.

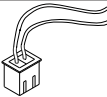
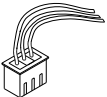
Usage	Name and shapes	Q'ty	Parts No.
For output port	EXTERNAL INPUT WIRE 	1	9368778002
For control input port	EXTERNAL INPUT WIRE 	1	9368779009

2-4-2 INDOOR UNIT (COMPACT WALL MOUNTED)

(1) Control input (Operation/Stop)

Indoor unit can be operated or stopped by using the connector CN10(RED) ON indoor unit PCB.

CONNECTOR	INPUT SIGNAL	COMMAND
CN10 (RED)	OFF → ON	Operation
	ON → OFF	Stop

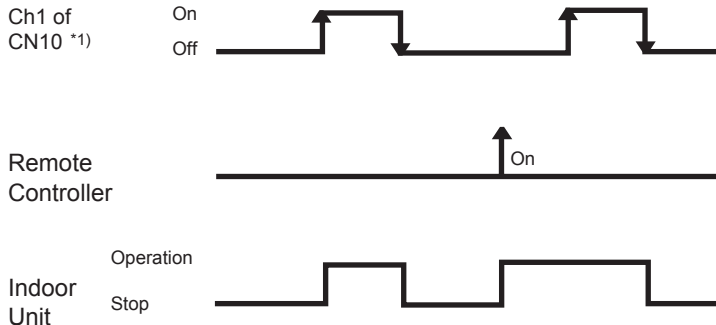
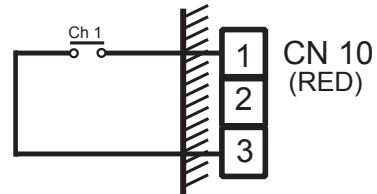

NOTE

1. The last command has priority.
2. The wire connection shall be separate from the power cable line.

(2) Output

CONNECTOR	OUT VOLTAGE	STATUS
CN11 (WHITE)	12V	Operation
	0V	Stop

① Operation display

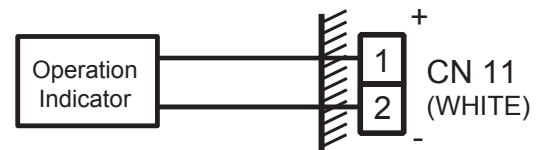
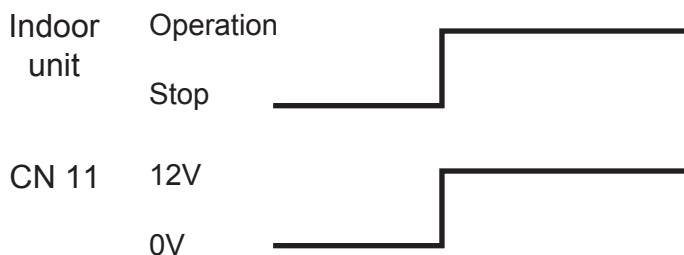

(3) Parts

Following cord (service parts) is required. Please use the parts number shown below to order the cord from your sales representative.

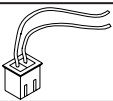
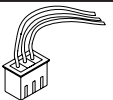
Usage	Name and shapes	Q'ty	Parts No.
For output port	EXTERNAL INPUT WIRE 	1	9368778002
For control input port	EXTERNAL INPUT WIRE 	1	9368779009

2-4-3 OUTDOOR UNIT

(1) Output

① Error display

This output indicates the outdoor unit and connected indoor unit's "Normal" or "Error" status.

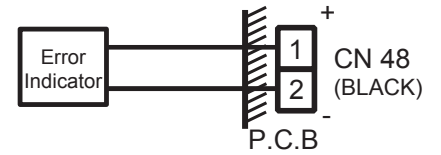

CONNECTOR	OUTPUT VOLTAGE	STATUS
CN48 (BLACK)	0V	Normal
	12V	Error

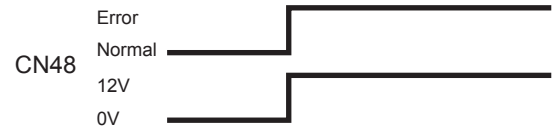

② Base heater output

Turn ON when the ambient temperature is low in heating mode.(2°C or less)

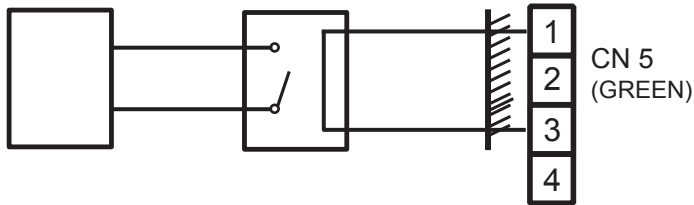

(2) Parts

Following cord (service parts) is required. Please use the parts number shown below to order the cord from your sales representative.

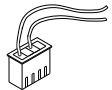
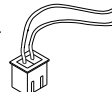
Usage	Name and shapes	Q'ty	Parts No.
For base heater output port	BASE HEATER WIRE 	1	9368776008
For error display output port	EXTERNAL INPUT WIRE 	1	9368777005

2-4-4 CENTRAL REMOTE CONTROLLER / PC CONTROLLER

(1) Input

① Control input (All on / All off)

Indoor units which stored into Central R.C. or PC controller can be operated or stopped by this input.

a) Input select

• Central remote controller

DipSW2-1	DipSW2-2	Input select
ON	OFF	"Edge"
ON	ON	"Pulse"

• PC controller

Input select can be set in environmental set up.
(Please refer to PC Controller's setting manual.)

b) In the case of "Edge" input

CONNECTOR		INPUT SIGNAL	COMMAND
CN9 (RED)	Ch1	OFF → ON	All ON
		ON → OFF	All OFF

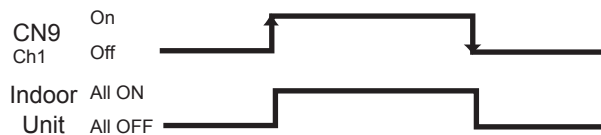
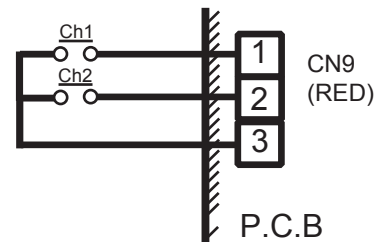

c) In the case of "Pulse" input

CONNECTOR		INPUT SIGNAL	COMMAND
CN9 (RED)	Ch1	OFF → ON	All ON
	Ch2	OFF → ON	All OFF

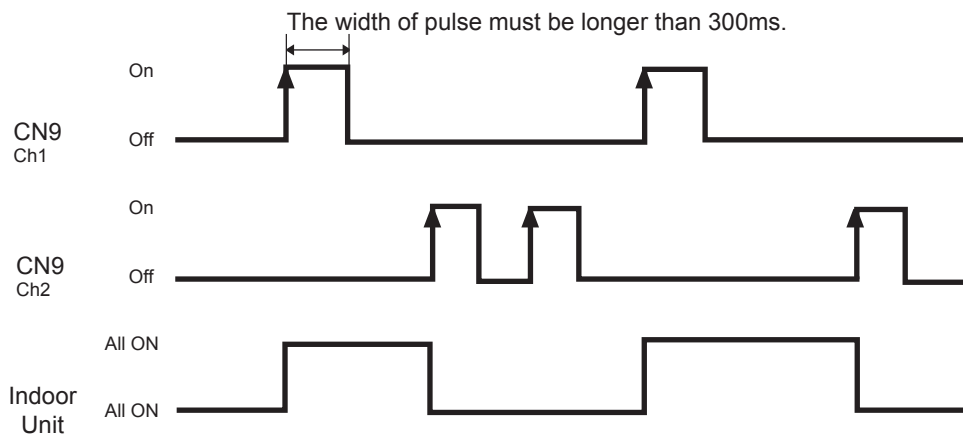

(2) Output

① Operation display

This output indicates the indoor unit's "Operate" or "Stop" status.

CONNECTOR		OUTPUT SIGNAL	STATUS
CN1 (WHITE)	Ch1	Open	All of indoor units "OFF"
		Short	At least one more indoor units "ON"

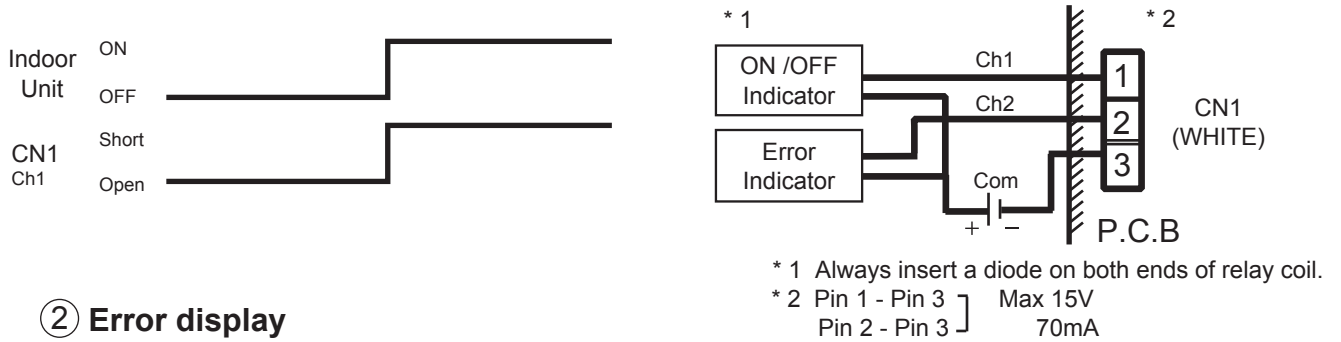

② Error display

This output indicates the indoor unit's "Normal" or "Error" status.

CONNECTOR		OUTPUT SIGNAL	STATUS
CN1 (WHITE)	Ch2	Open	All of indoor units "Normal"
		Short	At least one more indoor units "Error"

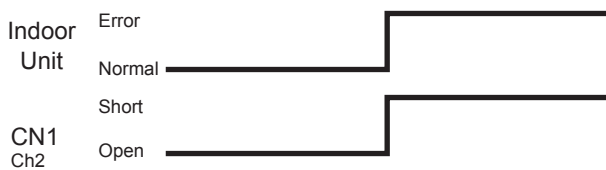

(3) Parts

Following cord (service parts) is required. Please use the parts number shown below to order the cord from your sales representative.

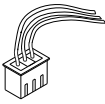
Usage	Name and shapes	Q'ty	Parts No.
For input and output port	EXTERNAL INPUT WIRE 	1	9368779009

2-4-5 NETWORK CONVERTOR

The connector positions and pin number of network convertor (UTR-YSSA) for external input and output are shown in the right figure.

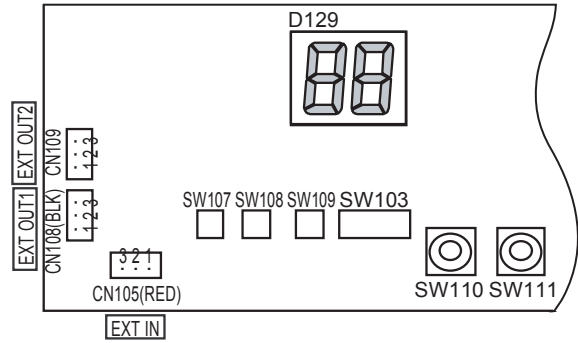

(1) Control input (Operation / Stop)

Indoor units that connected to network convertor can be controlled (all operation / all stop) by this input.

a) Input select

DipSW108-1	DipSW108-2	Input select
ON	OFF	"Edge"
ON	ON	"Pulse"

b) In the case of "Edge" input

CONNECTOR	INPUT SIGNAL	COMMAND
CN105 (RED)	Ch1	OFF → ON
	Ch1	ON → OFF
		All operation
		All stop

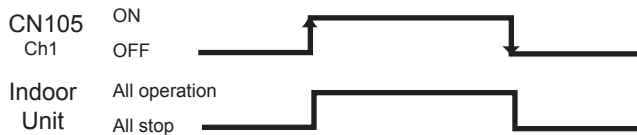
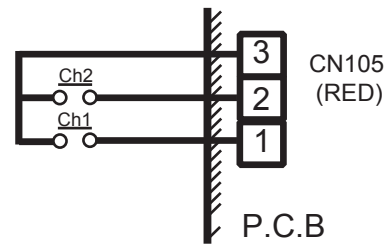

c) In the case of "Pulse" input

CONNECTOR	INPUT SIGNAL	COMMAND
CN105 (RED)	Ch1	OFF → ON
	Ch2	OFF → ON
		All operation
		All stop

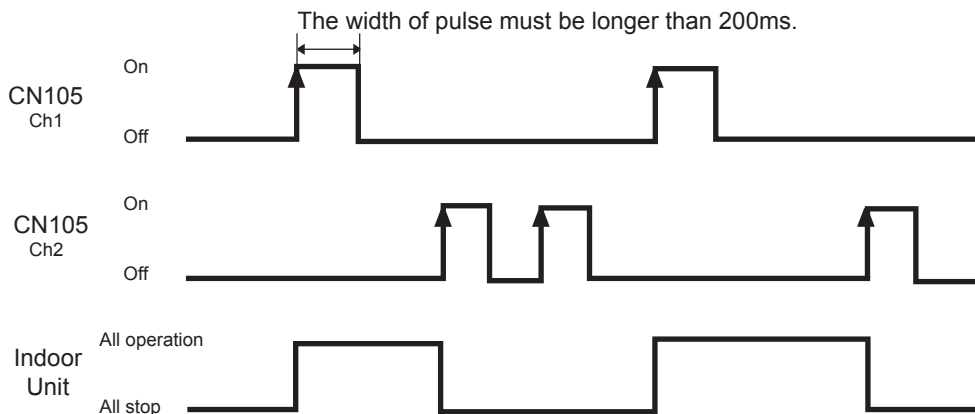

(2) Output

① Operation display (EXT OUT1)

This output indicates the indoor unit's "Operation" or "Stop" status.

CONNECTOR	OUTPUT SIGNAL	STATUS
CN108 (BLACK)	Open	Indoor units "Stop"
	Short	Indoor units "Operation"

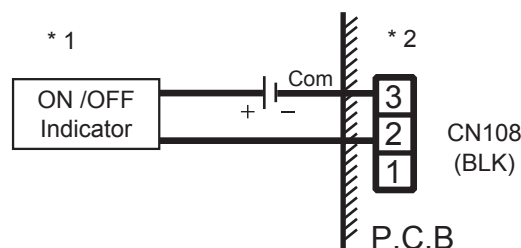
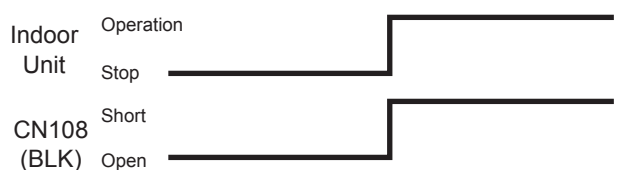

* 1 Always insert a diode on both ends of relay coil.

* 2 Pin 2 - Pin 3 Max 15V, 50mA

② Error display (EXT OUT2)

This output indicates the indoor unit's "Normal" or "Error" status.

CONNECTOR	OUTPUT SIGNAL	STATUS
CN109 (WHITE)	Open	All of the indoor units "Normal"
	Short	At least one more indoor units "Error"

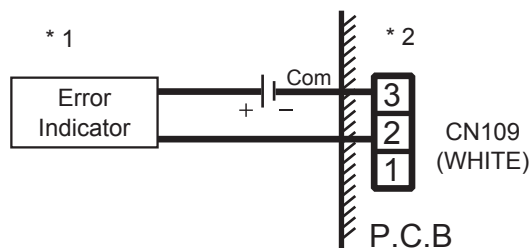

* 1 Always insert a diode on both ends of relay coil.

* 2 Pin 2 - Pin 3 Max 15V, 50mA

(3) Parts

Following cord (service parts) is required. Please use the parts number shown below to order the cord from your sales representative.

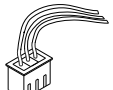
Usage	Name and shapes	Q'ty	Parts No.
For control input and output port	EXTERNAL INPUT WIRE 	1	9368779009

Refrigerant
R407C

AIRSTAGE™

3 . OUTDOOR UNIT OPERATION CONTROL

3. OUTDOOR UNIT OPERATION CONTROL

3-1 COMPRESSOR OPERATION CONTROL

3-1-1 OPERATION / STOP CONDITION

① Compressor operation condition

When cooling requirement capacity or heating requirement capacity from either of the indoor units in the same refrigerant system is input, the compressor operates.

But in the following case, the compressor operates in accordance with operation of each mode.

- During 3 minute restart prevention operation
- During compressor recovery operation
- During deicing operation
- Failure (except for a part)
- Defrosting
- Oil recovery
- Under expansion valve initialization
- At protective operation
 - * Central discharge temperature protection
 - * High pressure protection

② Compressor stop condition

When all the indoor units in no "cooling requirement capacity" or "heating requirement capacity ", all the compressors are stopped.

But, in the following case, the compressor operates in accordance with operation of each mode.

- Defrosting
- Oil recovery

3-1-2 COMPRESSOR OUTPUT PATTERN

The output pattern of a compressor is defined as below.

Compressor output pattern

OUTPUT PATTERN	COMPRESSOR 1 (2HP)	COMPRESSOR 2 (4HP)	COMPRESSOR 3 (6HP)
Step 0	OFF	OFF	OFF
Step 1	ON	OFF	OFF
Step 2	OFF	ON	OFF
Step 3	ON	ON	OFF
Step 4	OFF	OFF	ON
Step 5	ON	OFF	ON
Step 6	OFF	ON	ON
Step 7	ON	ON	ON

3-1-3 3 MINUTES RESTART PREVENTION (3 MIN ST)

When the compressor is stopped, the compressor does not start on any condition for 3 minutes afterwards. But, this function is excluded when defrosting, oil recovery is performed and the power is turned on.

3-1-4 COMPRESSOR RECOVERY OPERATION

If compressor 1, 2, or 3 fails, or if two compressors fail at the same time, the remaining compressor(s) perform recovery operation to prevent interruption of air conditioning system operation by a failure.

When compressor 1, 2, or 3 is judged to be faulty, the system is operated by switching the compressor output pattern (compressors 0 to 6) as shown in the following table.

Compressor failure is displayed by LEDs on the PCB of the outdoor unit and by output ERROR to the communication bus line (standard wired remote controller, central remote controller, PC controller).

- (a) When compressor 1 (2 HP) fails (compressor 2 is substituted for compressor 1)
- (b) When compressor 2 (4 HP) fails (compressor 3 is substituted for compressor 2)
- (c) When compressor 3 (6 HP) fails (compressor 1 and 2 are substituted for compressor 3)

Compressor recovery operation

ORDINARY OPERATION	RECOVERY OPERATION				
	(a)X-4-6*	(b)2-X-6*	(c)2-4-X*	(d)X-X-6*	(e)X-4-X*
Step 0	Step 0	Step 0	Step 0	Step 0	Step 0
Step 1	Step 2	Step 1	Step 1	Step 4	Step 2
Step 2	Step 2	Step 4	Step 2	Step 4	Step 2
Step 4	Step 4	Step 4	Step 3	Step 4	Step 2
Step 5	Step 6	Step 5	Step 3	Step 4	Step 2
Step 6	Step 6	Step 5	Step 3	Step 4	Step 2
Step 7	Step 6	Step 5	Step 3	Step 4	Step 2

*The character X represents the compressor(s) which was(were) stopped by a protection function or compressor error while the number(s) represent(s) capacity (in horse power) of the compressor(s) by which the recovery operation can be performed.

3-2 HEAT EXCHANGE CAPACITY CONTROL

The heat exchanger capacity and four-way valve, solenoid valve, and electronic expansion valve operation states are shown below.

1. Cooling, Cooling main

Pattern	4-way valve (4WV)			Solenoid valve (SV)		Electronic expansion valve (EEV)		Used heat exchanger(HP)			Remarks
	4WV2	4WV3	4WV4	SV7	SV8	EEV1	EEV2	2	4	6	
1	OFF	ON	ON	ON	OFF	Control pulse	0 pulse	○	×	×	Cooling 2HP
2	ON	OFF	ON	OFF	ON	Control pulse	0 pulse	×	○	×	Cooling 4HP
3	ON	ON	OFF	OFF	OFF	0 pulse	Control pulse	×	×	○	Cooling 6HP
4	OFF	ON	OFF	ON	OFF	Control pulse	Control pulse	○	×	○	Cooling 8HP
5	ON	OFF	OFF	OFF	ON	Control pulse	Control pulse	×	○	○	Cooling 10HP
6	OFF	OFF	OFF	ON	ON	Control pulse	Control pulse	○	○	○	Cooling 12HP

2. Heating, Heating main

Pattern	4-way valve (4WV)			Solenoid valve (SV)		Electronic expansion valve (EEV)		Used heat exchanger(HP)			Remarks
	4WV2	4WV3	4WV4	SV7	SV8	EEV1	EEV2	2	4	6	
1	ON	ON	ON	ON	OFF	Control pulse	0 pulse	○	×	×	Heating 2HP
2	ON	ON	ON	OFF	ON	Control pulse	0 pulse	×	○	×	Heating 4HP
3	ON	ON	ON	OFF	OFF	0 pulse	Control pulse	×	×	○	Heating 6HP
4	ON	ON	ON	ON	OFF	Control pulse	Control pulse	○	×	○	Heating 8HP
5	ON	ON	ON	OFF	ON	Control pulse	Control pulse	×	○	○	Heating 10HP
6	ON	ON	ON	ON	ON	Control pulse	Control pulse	○	○	○	Heating 12HP

3. Stop and same capacity operation

Pattern	4-way valve (4WV)			Solenoid valve (SV)		Electronic expansion valve (EEV)		Used heat exchanger(HP)			Remarks
	4WV2	4WV3	4WV4	SV7	SV8	EEV1	EEV2	2	4	6	
1	OFF	OFF	OFF	OFF	OFF	280 pulse	280 pulse	×	×	×	Stop
2	ON	ON	ON	OFF	OFF	0 pulse	0 pulse	×	×	×	Same capacity

3-3 OUTDOOR FAN MOTOR CONTROL

1 ON /OFF

The outdoor fan motor is turned on with the compressor start and turned off with the compressor stop except for the following cases. Also when the operating mode of the outdoor unit is changed, fan speed will be controlled under new operating mode condition.

- When the defrosting operation is performed
- When the deicing operation is performed
- When the same capacity mode is performed
- When the overload protection operation during heating operation is performed

2 Fan Speed

The outdoor fan motor has the following five steps of speed in addition to Stop.

FAN SPEED	FAN 1	FAN 2
1	Hi	Hi
2	Hi	Stop
3	Lo	Lo
4	Lo	Stop
5	Intermittent *	
6	Stop	Stop

* Intermittent operation: Fan 1 rotates 20 seconds at intervals of 50 seconds. Fan 2 stops all the time.

3 Fan Speed Switching

(a) Fan speed of cooling mode, cooling main mode and oil recovery operation

The following table shows the fan speed associated with outdoor temperature.

Fan speed switched according to outdoor temperature

OUTDOOR TEMPERATURE (TH _o)	NORMAL OPERATING MODE	SILENT OPERATING MODE
TH _o > 30°C	1	1
30°C ≥ TH _o > 27°C	1	3
27°C ≥ TH _o > 18°C	3	3
18°C ≥ TH _o > 6°C	4	4
6°C ≥ TH _o	5	5

(b) Fan speed of heating mode and heating main mode

The fan 1 and fan 2 rotate in High-High speed.

(c) Same capacity fan control

When the operating mode of the outdoor unit is the same capacity mode, the fan fan1 and fan2 are turned off.
When the operating mode of the outdoor unit is changed from the same capacity operating mode to another operating mode, the fan operates in accordance with the new operating mode.

3-4 EXPANSION VALVES 1 AND 2 CONTROL

1) Purpose of the control

In order to balance the refrigerant flow rate of each heat exchanger and to adjust the refrigerant gas to an optimum state, a feedback control of expansion valves 1 and 2 is performed by using operation date which is obtained with thermistors and pressure sensors.

2) Operation flow chart of expansion valves

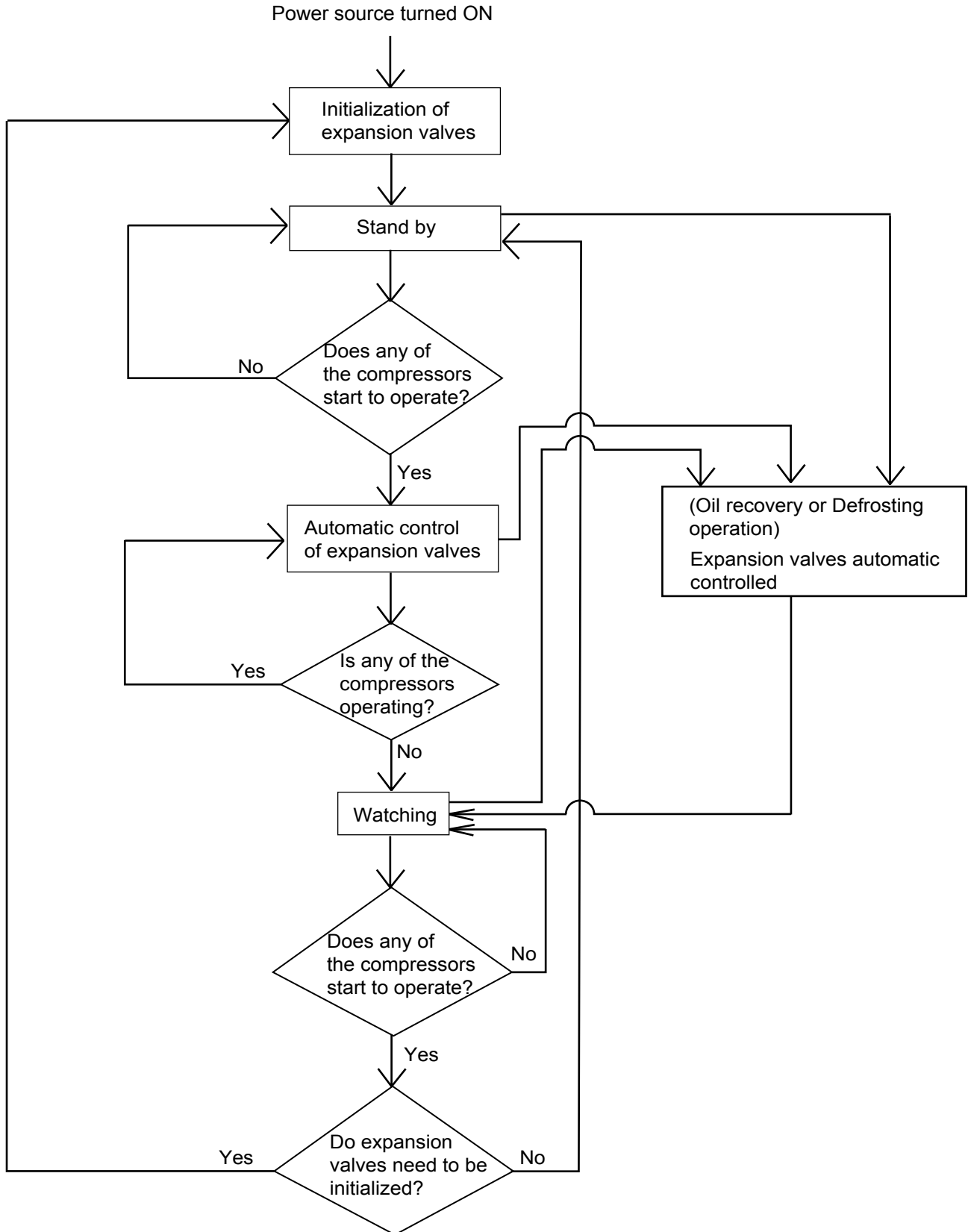

* The expansion valves are initialized at intervals of 4 hours (about).

3-5 CIRCULATING SAVE AMOUNT CONTROL

1) Expansion Valve 3 Control

As there is a difference between compressor's actual capacity (operating capacity) and required capacity (from indoor units), the difference in capacity is bypassed as a circulating save amount.

(Operating capacity – required capacity)

2) Start condition

When all the following conditions are satisfied.

- (1) Compressor(s) is(are) operating, except for the case that only compressor 1 (2HP) is operating.
- (2) Operating mode is "Cooling" or "Heating".

3) End condition

When any of the following condition is satisfied.

- (1) Only compressor 1 (2HP) is operating.
- (2) When the operating mode is switched to other than "Cooling" or "Heating".

3-6 SOLENOID VALVE 2 CONTROL

The solenoid valve 2 is controlled according to the difference between operating capacity and required capacity during the same capacity operation mode.

3-7 DEFROSTING CONTROL

1) Purpose of operation

By removing the frost that was formed on the surface of the outdoor unit heat exchanger, the defrosting operation prevents a decline in heat transfer efficiency and realizes an efficient heating operation.

2) About the defrosting operation

(1) Starting condition of the defrosting operation

The defrosting operation starts when all the following conditions are satisfied.

- Outdoor unit operation mode is "heating".
- Integrated time which any of the compressors is operating has reached 40 minutes or longer.
- The temperature of outlet of heat exchangers has become lower than the set temperature for starting a defrosting operation. (See 2-3-2 for the information on defrost temperature setting.)
- When compressor(s) starts to operation from "all compressors stopped" state, and has operated continuously for more than 6~10 min.

The defrosting operation can also be performed by setting the forced defrost operation DIP SW 1- 4 from OFF to ON, and keeping it at ON position for more than 10 seconds. To stop the defrosting operation, set the DIP SW1- 4 to OFF.

(2) Defrosting start restrictions

When oil recovery operation is in progress or errors or protections (except for some) were generated, Defrosting operation will not be performed even if the conditions mentioned above are satisfied.

(3) End condition of the defrosting operation

When any of the following conditions is satisfied, defrosting operation ends.

- Outdoor unit operation mode was switched to other than "Heating"
- 20 minutes or longer have elapsed since defrosting operation started.
- Integration of compressor operation time after start of defrosting has exceeded 15 minutes.
- The error was generated, except for some error conditions.
- Each heat exchanger outlet temperature has reached defrosting end heat exchanger temperature 10°C or higher.

3) Others

During the defrosting operation the fans of indoor units stop, **DEFROST** appears on the display of wired and central remote controller, and  appears on the simple remote controller. The operation indicators (LED) of the indoor units flash slowly.

3-8 OIL RETURN CONTROL

1. Two kinds of oil return control

There are two oil return controls, one is the individual oil return control and the other one is centralized oil return control. When any of the solenoid valves opens, the oil return is performed.

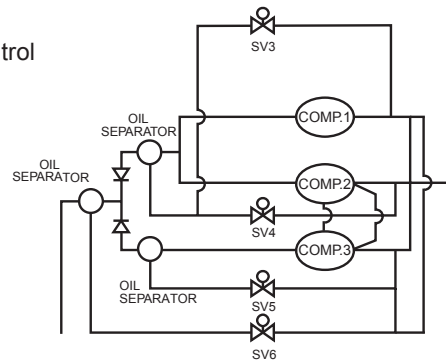

2. Oil return solenoid valves

	Solenoid valve	Application
Individual oil return control	Solenoid valve SV3	Compressor 1
	SV4	Compressor 2
	SV5	Compressor 3
Central oil return control	SV6	Compressor 1/2/3

3. Individual oil return control

When a compressor operates continuously for 1 minute or longer and any of the following conditions is satisfied, the solenoid valve corresponding to the compressor opens for 10 seconds to return the oil accumulated in the oil separator to the compressor.

- (1) The integrated operating time of the compressor has reached 15 minutes or longer.
- (2) The compressor is stopped.

4. Central oil return control

When any of the following conditions is satisfied, the solenoid valve SV6 opens on and central oil return control begins.

- (1) One or more compressors are operating and the integrated time of "1 or more compressors operating" state exceeds 15 minutes
- (2) All the compressors are stopped.

3-9 OIL RECOVERY CONTROL

1) Purpose of the operation

The amount of refrigerant machinery oil which has been transported to the indoor units and the connection pipe with the refrigerant will become large as the operation time of compressor increase. It is necessary to recover the oil back into the outdoor unit for a certain time interval in order to prevent compressors from damaging due to lack of lubrication oil.

2) About the oil recovery operation

When "oil recovery integrated time", which is the integrated operating time of any compressor in operation, reaches to the certain time, the oil recovery operation starts.

The "oil recovery integrated time" to start the oil recovery is as follows.

- The first time of oil recovery after the power is turned on : 1 hour
- The second time and afterwards : At intervals of 4~6 hours

Please note that "oil recovery integrated time" is reset to zero at the end of defrosting operation.

The oil recovery operation can be performed by setting the forced oil recovery DIP SW2-4 from OFF to ON and keeping it at ON position for more than 10 seconds.

3) The operation of compressors and fans

The following time chart shows the behavior of compressors, outdoor fan and indoor fan during oil recovery operation.

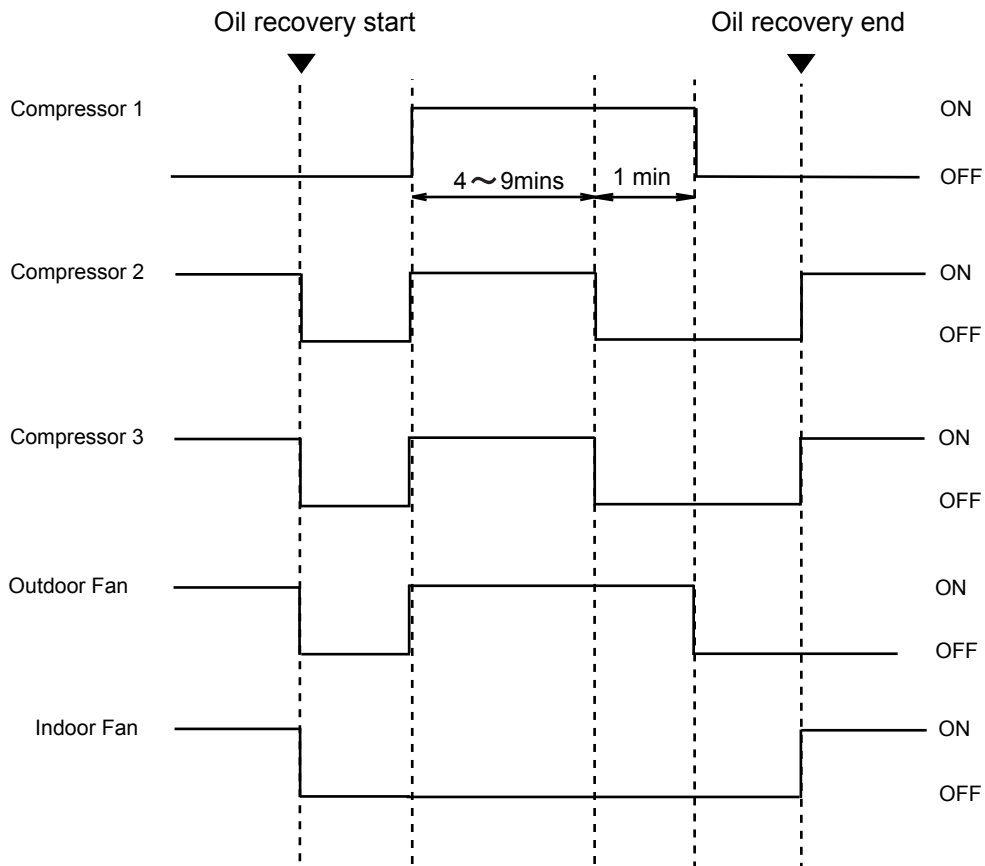

4) Others

During the oil recovery operation, **DEFROST** appears on the display of wired and central remote controller, and  appears on the simple remote controller.

The operation indicators (LED) of the indoor units flash slowly.

3-10 PROTECTION FUNCTIONS

1. Central discharge temperature protection

- 1) When the discharge temperature of any compressor reaches 110 °C or higher, solenoid valve 1 (SV1) is turned on and bypass is performed. SV1 is turned off and central discharge temperature protection operation is ended by any of the following conditions:
 - (1) Discharge temperature of all compressors reaches 95 °C or lower.
 - (2) Oil recovery operation starts.
- 2) When solenoid valve 1 (SV1) is on and the outdoor fan speed is "5"(about fan speed, please refer to 3-3), solenoid valve 2 (SV2) is simultaneously turned on and bypass is performed. SV2 is turned off by any of the following conditions:
 - (1) Outdoor fan speed is set to other than "5".
 - (2) Oil recovery operation starts.
 - (3) Discharge temperature of all compressors reaches 95 °C or lower.

2. Discharge temperature protection

When the discharge temperature of any compressor reaches 130 °C or higher, the corresponding compressor stops. Compressor stop is reset and discharge temperature protection operation is ended by any of the following conditions:

- (1) Discharge temperature of all compressors reaches 95 °C or lower.
- (2) Oil recovery operation starts.

However, during oil recovery operation, discharge temperature protection is not performed.

3. High-pressure protection

- 1) When the high-pressure SW (HP) is turned off except during oil recovery operation or defrosting, solenoid 1 (SV1) and solenoid 2 (SV2) are turned on and bypass is performed. SV1 and SV2 are turned off by any of the following conditions:
 - (1) High-pressure pressure SW turned on.
 - (2) Oil recovery control starts.
 - (3) Defrosting control starts.
- 2) When 1 minute has elapsed after SV1 and SV2 were turned on and the discharge pressure sensor detected value is 3.34MPa or higher, compressors 1, 2, and 3 are stopped. SV1 and SV2 ON and compressors 1, 2, and 3 stop are reset and high-pressure protection operation is ended by any of the following conditions:
 - (1) High-pressure SW turned on.
 - (2) Oil recovery control starts.
 - (3) Defrosting control starts.

4. Heating overload protection

When the operating mode is " Heating " and the high-pressure SW was turned off except during oil recovery or defrosting in the "Heat mode", the outdoor fan is stopped. Outdoor fan stop is reset and heat overload protection operation is ended by any of the following conditions:

- (1) High-pressure SW turned on.
- (2) Oil recovery control starts.
- (3) Defrosting control starts.
- (4) Mode is switched to other than "Heat".

Refrigerant
R407C

AIRSTAGE™

4 . INDOOR UNIT OPERATION

4. INDOOR UNIT OPERATION

4-1 TIMER CONTROL

There are three timer modes: "OFF TIMER", "ON TIMER" and "WEEKLY TIMER".

- (1) Set the clock time when the unit is in the stop mode (only the current time will be shown on the remote control unit display).
- (2) While adjusting the current clock time, do not use other remote control functions.
- (3) Each time the TIMER button is pressed, the remote control unit display will change in the order shown below:

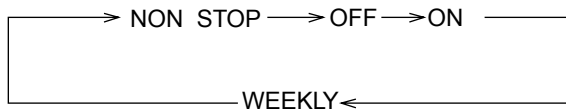

1) OFF timer

When the timer mode is set to "OFF timer", operation automatically stops when the set time has elapsed.

2) ON timer

When the timer mode is set to "ON TIMER", operation automatically starts when the set time has elapsed.

3) WEEKLY timer

Use the weekly timer to set operating times for each day of the week.

Weekly Timer Features

- Set different operating times for each day of the week.
- Set one or two operating spans (one or two ON times and one or two OFF times) per day.
- Set time to a resolution of 5 minutes.
- OFF time can be carried over to the subsequent day.
- Use the "DAY OFF" setting to cancel operation for any day of the coming week (one-time cancellation).

Remote control button selected

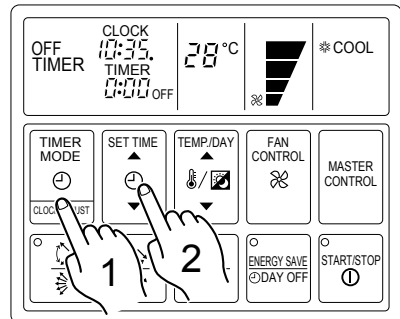

OFF timer setting

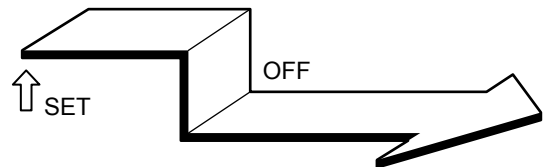

ON timer setting

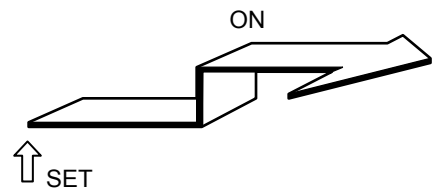

Setting Up the Weekly Timer Operation

Press the START/STOP button to stop the air conditioner, and then proceed as follows.

1. Press the **TIMER MODE** button so that **"WEEKLY"** appears on the display.

The display now shows the current day (by DAY CODE), the first ON and OFF times for the day (the "WEEKLY 1" times), the fan speed, and the operating mode.

The top time value gives the ON time, and the bottom value gives the OFF time.

If either time is not set, the corresponding time display is blank " -:-: -:-".

2. Press the **TEMP./DAY** button to select the day that you want to set up.

▲ : Use to advance the day forward.

▼ : Use to turn the day back.

DAY CODE	1	2	3	4	5	6	7
DAY OF THE WEEK	MON	TUE	WED	THU	FRI	SAT	SUN

3. Hold the **SET** button down for 3 seconds.

The "WEEKLY 1" ON time starts flashing, and the fan speed and operating mode displays go off.

4. Press the **SET TIME** button to set the day's first ON time.

▲ : Use to advance the day forward.

▼ : Use to turn the day back.

(Press once to move the time 5 minutes; hold down and the time will move 10 minutes at a time.)

The following procedures of 5, 6, 7 is for UTB- *LB type wired remote controller. Goto 8 directly when UTB- *LA is used.

5. Press the **TIMER MODE** button.

The day display changes to the set temperature display.

6. Press the **MASTER CONTROL** and the **TEMP./DAY** button.

Select the desired operation mode and temperature.

7. Press the **TIMER MODE** button.

End operation mode and temperature setting.

8. Press the **SET** button.

This registers the first ON time setting for the selected day.

The ON time display stops flashing, and the "WEEKLY 1" OFF time starts flashing.

9. Press the **SET TIME** button to set the day's first OFF time.

The earliest OFF time you can set is 5 minutes after the ON time. The latest OFF time is 23:55 on the subsequent day.

10. Press the **SET** button.

This registers the first OFF time for the day, completing the "WEEKLY 1" settings for that day.

The display switches to "WEEKLY 2", and the day's second ON time begins flashing.

11. Repeat the operations described in Steps 4 to 10 to set the second ON and OFF times for the day (the "WEEKLY 2" times).

When you press the SET button after setting the "WEEKLY 2" OFF time, the system registers the "WEEKLY 2" settings for the day and returns you to the "WEEKLY 1" ON time setup process. (The first ON setting reappears and begins flashing.) You can review your settings by pressing the SET button. Each press moves you to the next setting, as follows.

UTB - *LA

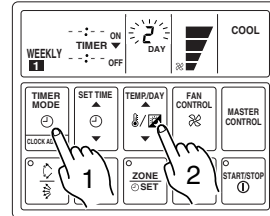

UTB - *LB

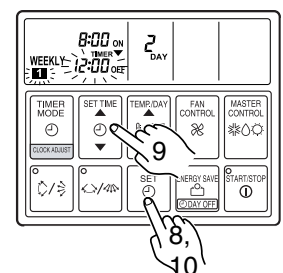
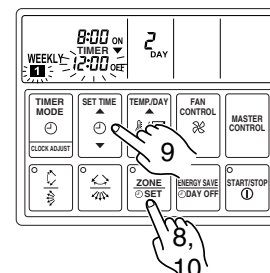
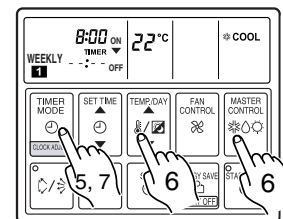
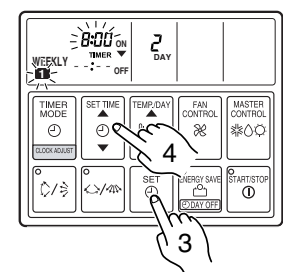
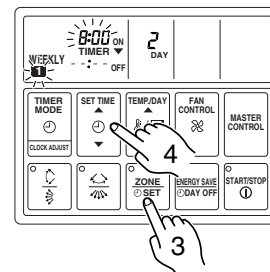
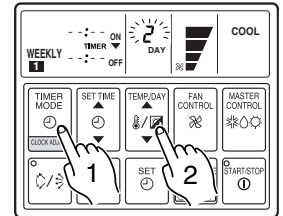

If the timer is not set, press the SET button with the time display blank " -:-: -:-", and perform next operation.

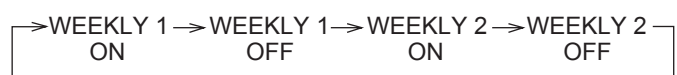

12. Press the SET TEMP./DAY button to select another day for setup. The repeat steps 4 to 10 above to set the ON and OFF times for that day.

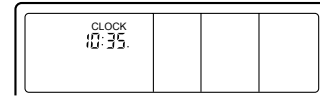

13. When you have finished setting all of the times, hold down the SET button for 3 seconds. The WEEKLY display flashes for 3 seconds while the new WEEKLY TIMER settings are registered, and then the clock display reappears.

NOTES:

- (1) If no time values are flashing, the clock display will automatically reappear after 15 seconds if no buttons are pressed.
- (2) A flashing time value indicates that the system is in time-setting mode. To return to the clock display you must hold down the SET button for 3 seconds.
- (3) You do not need to set values for both WEEKLY 1 and WEEKLY 2. If you wish, you can set values only for WEEKLY 1 or only for WEEKLY 2.
- (4) The allowable range for the day as time settings is shown below.

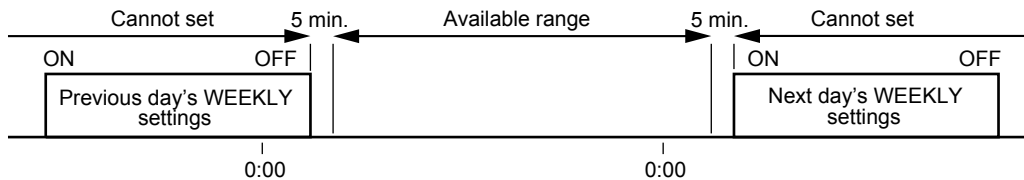

(5) If you set the OFF time to occur on the day following the ON time, the NEXT DAY caption appears on the display.

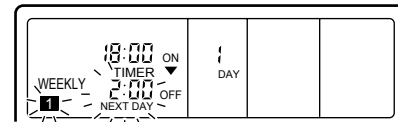

Starting Weekly Timer Operation

1. Press the TIMER MODE button so that "WEEKLY" appears on the display.
2. Press the START/STOP button to start operation. (This step is not necessary if the air conditioner is already running.)

Weekly timer operation starts, and the operation lamp comes on. (If the current time is between the first or second ON and OFF time settings for the current day, the air conditioner will start. Otherwise the air conditioner will remain off.)

The day display is replaced by the temperature display. The upper time display now shows the current time, and the lower time display shows the next scheduled ON or OFF time.

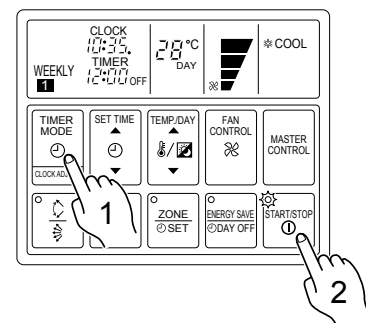

To Stop Weekly Timer Operation

- To stop weekly timer while leaving the air conditioner running:
Press the TIMER MODE button to select NONSTOP, OFF TIMER, or ON TIMER.
- To stop weekly timer operation and the air conditioner also:
Press the START/STOP button.

Reviewing the Time Settings

Press the START/STOP button to stop the air conditioner, and then proceed as follows.

- 1 Press the TIMER MODE button so that "WEEKLY" appears on the display.
- 2 Press the TEMP./DAY button to select the day that you want check.
- 3 Press the SET TIME button (▲ or ▼) to switch between the "WEEKLY 1" or "WEEKLY 2" time displays.

About the DAY OFF setting

- Use the DAY OFF setting to switch off timed operation for a selected day in the coming week.
- This is a temporary, one-time setting. The DAY OFF setting is automatically cleared as soon as the specified day passes.

Using the DAY OFF Setting

Press the START/STOP button to stop the air conditioner, and then proceed as follows.

1. Carry out steps 1 to 2 of the "Setting Up the Weekly Timer Operation" procedure to select the day that you want to set as the DAY OFF.
2. Press the DAY OFF button.

The DAY OFF setting is registered, and the DAY OFF caption appears on the display.

- To cancel the DAY OFF setting:
You can cancel the setting by pressing the DAY OFF button again.

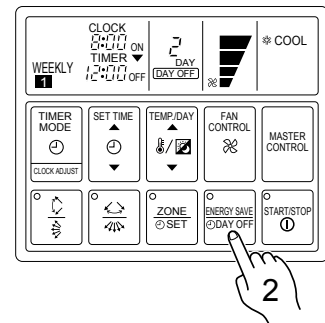

Example : To switch off timed operation for day 2 (Tuesday).

NOTES:

- (1) The DAY OFF setting is only available for days for which weekly time settings already exist.
- (2) You can make this setting for any of the next seven days (counting from the current day).
- (3) The DAY OFF setting is effective over the range illustrated below. The weekly setting for which an ON time has been set is eligible for the day in which the DAY OFF has been set.

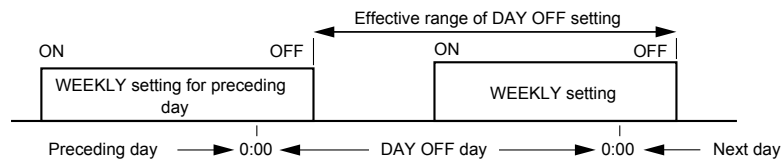

- (4) The display on the clock's lower line will usually be " --:-- " for the DAY OFF set day during weekly operations

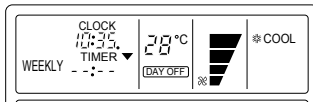

Precautions during setup

Setup is not possible in the following cases, so amend the time.

- If you set an ON time while leaving the OFF time setting blank:
Nothing will happen when you press the SET button.
To proceed, press the SET TIME button and enter an appropriate setting.
- When an attempt is made to set only the OFF time.
Nothing will happen when you press the SET TIME button.
Press the SET button and amend the entry for the ON time.
- ON and OFF times cannot be set to the same value.
- The OFF time cannot be set earlier than the ON time.
- The WEEKLY 2 settings cannot be set earlier than the WEEKLY 1 settings.
- The WEEKLY 1 and WEEKLY 2 time spans cannot overlap.

Canceling Selected Time Settings

Press the START/STOP button to stop the air conditioner, and then proceed as follows.

1. Carry out steps 1 to 3 of the "Setting Up the Weekly Timer Operation" procedure to select the day you want to edit.
2. Press the SET button to select the ON time that you want to cancel.

Be sure to select an ON time (the upper time display).

3. Hold down the ▼ side of the SET TIME button until the time display becomes blank "----".
4. Press the SET button.

The first OFF time setting ("WEEKLY 1" OFF time) is deleted and replaced by a flashing blank pattern "----".

5. Press the SET button again. This completes deletion of the "WEEKLY 1" ON/OFF settings. The second ON time setting ("WEEKLY 2" ON time) appears and flashes.

If you wish to delete other time settings, repeat steps 2 through 5.

6. Once the setting has been canceled, hold down the SET button for 3 seconds.

The WEEKLY display flashes briefly, and then the clock display appears.

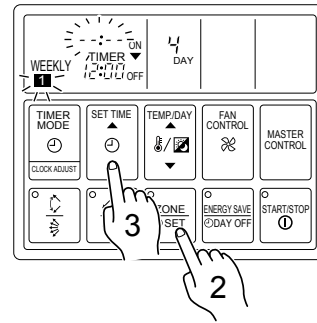

Example : Clearing the "WEEKLY 1" ON/OFF times for day 4 (Thursday).

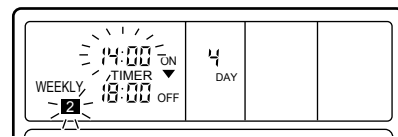
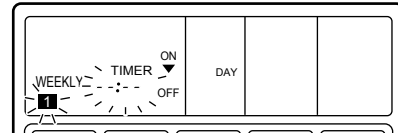

To Change Selected Time Settings

Press the START/STOP button to stop the air conditioner, and then proceed as follows.

1. Carry out steps 1 to 3 of the "Setting Up the Weekly Timer Operation" procedure to select the day you want to edit.
2. Press the SET button to select the time that you want to change. The selected setting flashes on the display. Each press moves you to the next setting for the selected day, as follows.

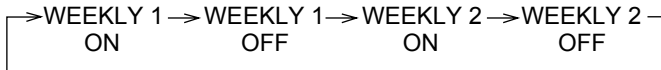

3. Press the SET TIME button to change the time setting. The new setting overwrites the previous setting.
4. Press the SET button. The new setting overwrites the previous setting.
5. Once the setting has been canceled, hold down the SET button for 3 seconds. The WEEKLY display flashes briefly, and then the clock display appears.

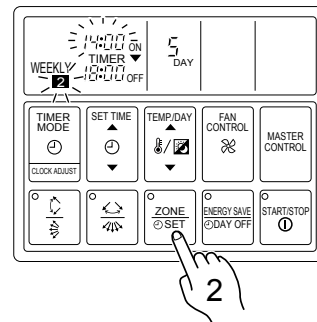

Example : Changing the "WEEKLY 2" ON setting for day 5 (Friday) from 14:00 to 15:30.

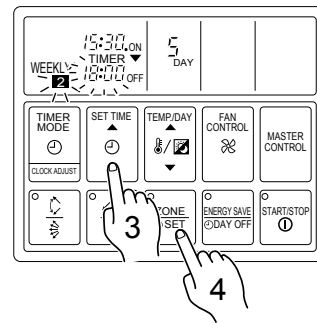

NOTES:

In the following cases, cancel the set time prior to making the required amendments.

- (1) If you want to change the ON time to a time that is later than the currently set OFF time.

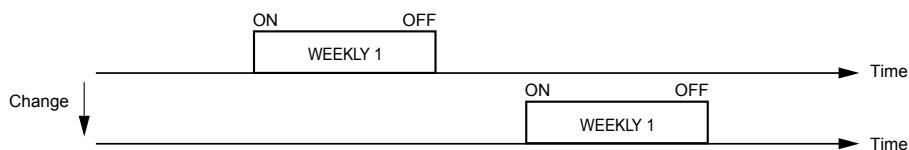

- (2) If the change would cause a temporary overlap between the first and second ON/OFF time spans.

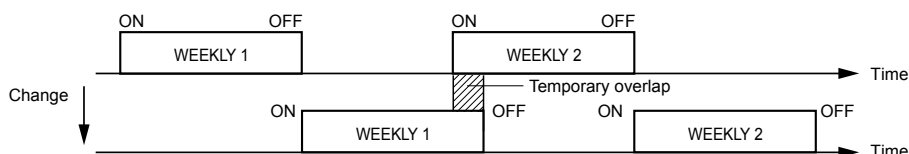

4-2 FAN CONTROL

4-2-1 "AUTO" POSITION

1) COOLING OPERATION

The fan speed is determined automatically in accordance with the condition " $(T_R(\text{corrected room temperature}) - T_s(\text{corrected set temperature}))$ " as shown on the right. However, the fan speed zone is determined in the manner as the room temperature increases for the following cases.

- (1) When the T_s is changed.
- (2) When the operation mode is changed from other mode to "COOL".
- (3) When the fan control is changed from other position to "AUTO".

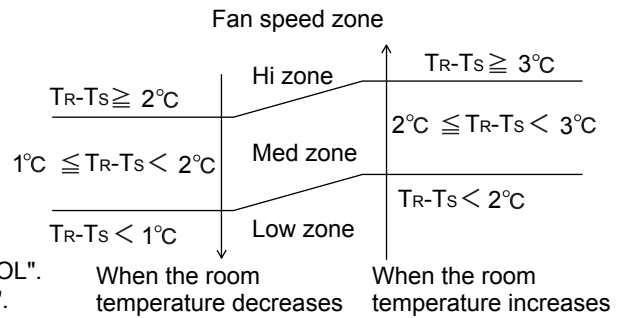

2) HEATING OPERATION

- (1) When the indoor heat exchanger temperature reaches 47°C or more, the fan speed switches to the next higher position. ("LOW" \rightarrow "MED", "MED" \rightarrow "HIGH").
- (2) When the indoor heat exchanger temperature drops below 41°C while the refrigerant circulation of the indoor unit is ON, the fan speed switches to the next lower position ("HIGH" \rightarrow "MED", "MED" \rightarrow "LOW").
- (3) After switching the fan speed, it does not switch again within 2 minutes.
- (4) When "FAN CONTROL" is switched from a set fan speed to "AUTO" after the cold air prevention is released, the fan of indoor unit will start at "MED" speed for $T_{HE} \geq 41^\circ\text{C}$ or at "LOW" speed for $T_{HE} < 41^\circ\text{C}$.

An example for heat operation

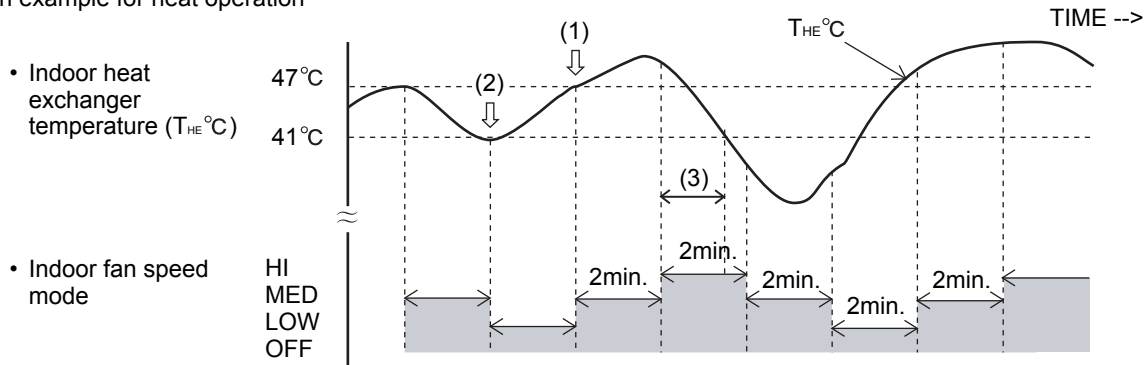

3) DRY OPERATION

The indoor fan always rotates at "Lo" speed.

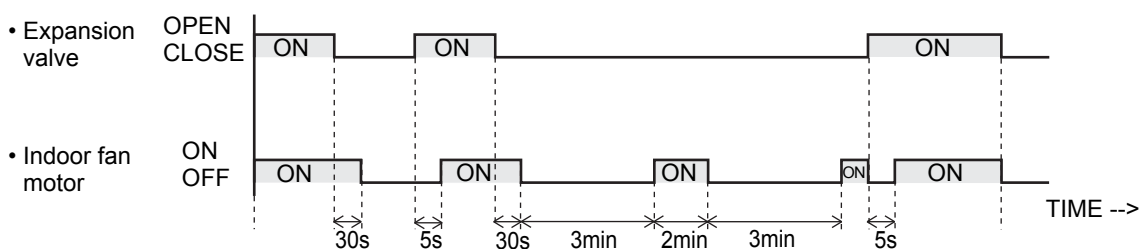

- (1) The indoor fan starts operation 5 seconds after the electric expansion valve opens. However, when the indoor unit just starts its operation or the operation mode is changed from other to "DRY" and the refrigerant circulation is not stopped, the fan will rotate immediately without a delay time of 5 seconds.
- (2) The indoor fan will stop in 30 seconds when the refrigerant circulation stops.
- (3) The indoor fan will stop immediately when the indoor unit is stopped by pushing the stop button or by a setting of ON timer.
- (4) When the refrigerant circulation is stopped due to a lower room temperature for more than 3 minutes, the fan will rotate 2 minutes at intervals of 3 minutes.
- (5) When the indoor unit just starts its operation or the operation mode is changed from other to "DRY" and the refrigerant circulation is stopped, the fan will rotate for 1 minute and then it will operate according to the statement (4).

4) FAN OPERATION

The indoor fan rotates continuously at "Lo" speed.

4-2-2 "LOW", "MED" AND "HIGH" POSITION

The indoor fan operates at the fan speed set with the FAN CONTROL mode button.

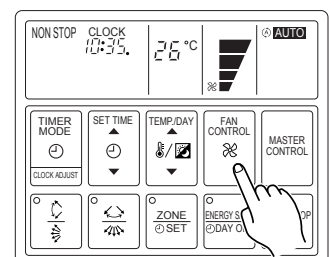

4-3 MASTER CONTROL

4-3-1 OPERATING MODE CONTROL

Each operating mode is controlled as below.

		Cool	Fan	Heat	Dry	Stop	
Indoor fan motor		Operates according to the AIR FLOW-MODE setting, and besides frost prevention operation	Operates according to the AIR FLOW-MODE setting.	Operates according to the AIR FLOW-MODE setting, and besides <ul style="list-style-type: none"> • Cold air prevention • Defrost operation 	See the fan control page.	Off	
RB Unit	Discharge valve (SV _D)	Close	Close	Open	Close	Close	
	Suction valve (SV _S)	Open	Close	Close	Open	Close	
	By-pass valve	SV _{B1}	Open	Open	Close	Open	Open
		SV _{B2}	Close	Close	Open	Close	Close
Drain pump		Turns ON-OFF by the drain pump control function					
Electrical expansion valve		Pulse controlled by the temperature difference calculation and frost prevent fuction	Stop pulse	Pulse controlled by the temperature difference caculation and the defrosting function	Pulse controlled by the temperature difference calculation and frost prevent function	Stop pulse	

• UTF-Y90A4A

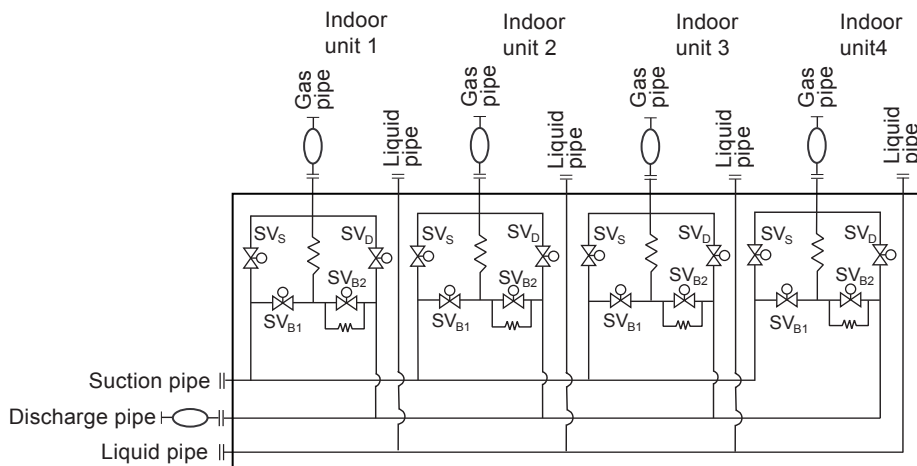

• UTF-Y54A1A

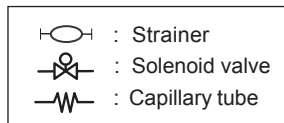
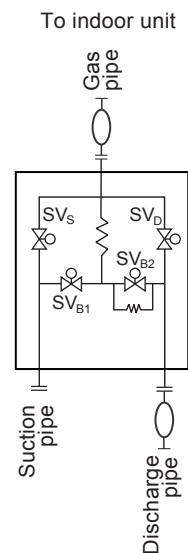

Schematics of the RB units

4-3-2 "AUTO" (Auto changeover) POSITION

- (1) When AUTO CHANGEOVER is selected, the air conditioner selects the appropriate operating mode (Cooling or Heating) according to your room's present temperature.
- (2) When AUTO CHANGEOVER is first selected, the fan will operate at very low speed for about one minute while the unit determines the current conditions of the room and accordingly selects the proper operating mode.
- (3) When the air conditioner has adjusted your room's temperature to near the set temperature, it will begin monitor operation. In the monitor operating mode, the fan will operate at low speed. If the room temperature subsequently changes, the air conditioner will once again select the appropriate operation (Heating, Cooling) to adjust the temperature to the set temperature.
- (4) If the mode automatically selected by the unit is not satisfactory, you can change the operating mode by press the MASTER CONTROL button to select the desired mode.

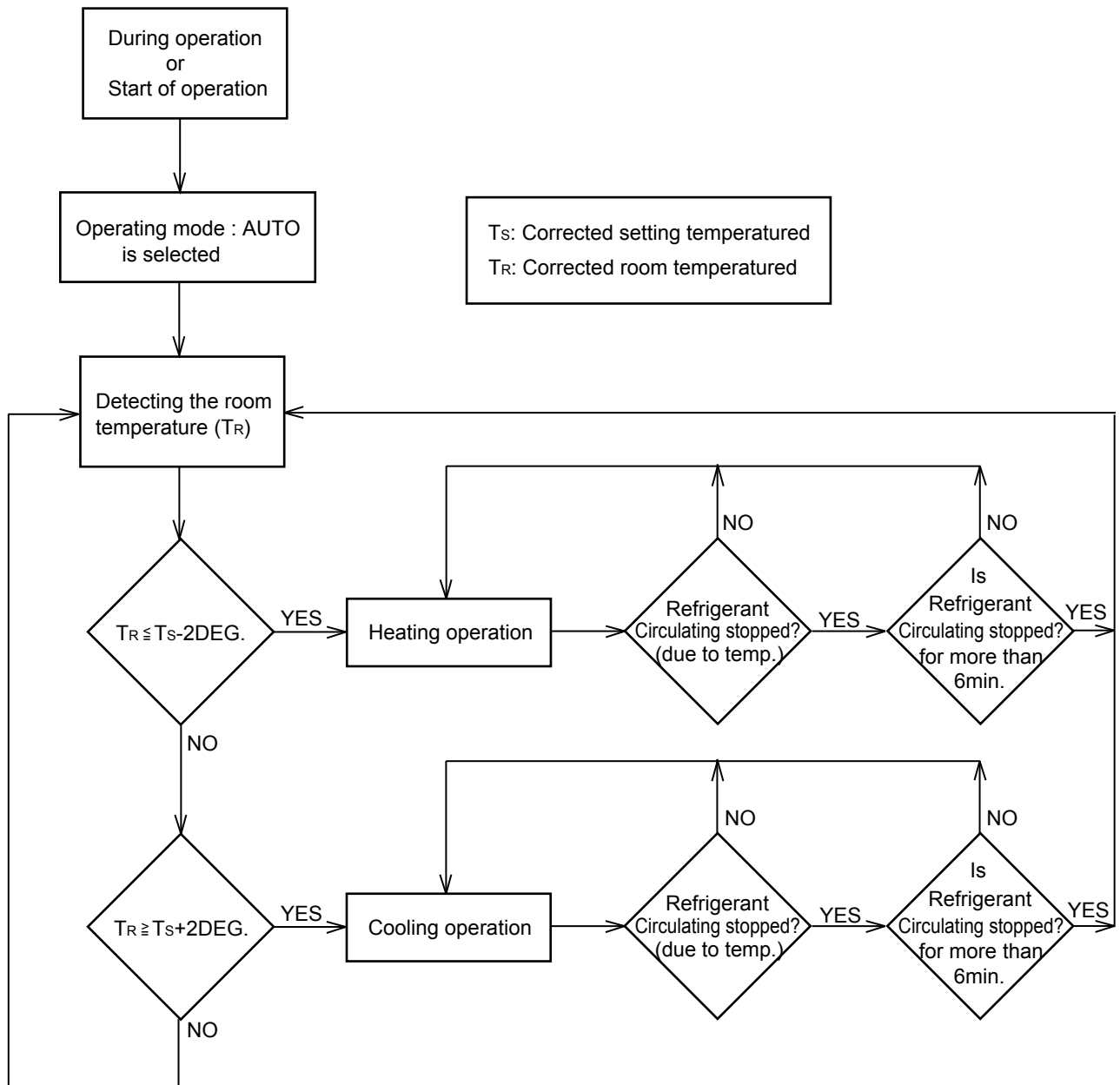
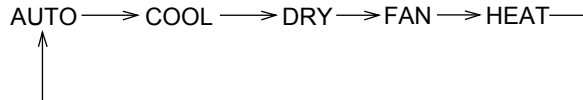

4-3-3 "COOL" POSITION

When using the cooling mode, set the temperature to a value lower than the current room temperature, otherwise the indoor unit will not start the cooling operation and only the fan will rotate.

An example for COOLING TEMPERATURE CONTROL time chart (Manual setting)

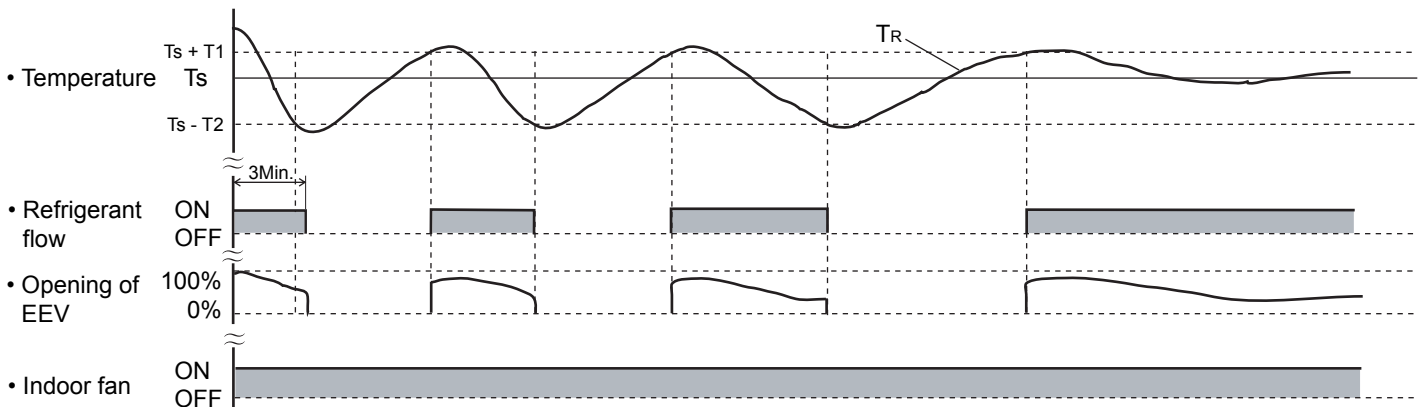

T_s : Corrected setting temperature
 T_R : Corrected room temperature

$T_s + T1$: The threshold temperature of start of refrigerant flow
 $T_R - T2$: The threshold temperature of stop of refrigerant flow

4-3-4 "HEAT" POSITION

- (1) When using the heating mode, set the temperature to a value higher than the current room temperature, otherwise the indoor unit will not start the heating operation.
- (2) After the start of heating operation, the fan of indoor unit will not rotate until the heater exchange is warmed up to blow out warm air.
- (3) During defrosting, the OPERATION indicator lamp flashes 3 sec. ON and 1 sec. OFF, and repeat. The heating operation will be temporarily interrupted.

An example for HEATING TEMPERATURE CONTROL time chart (Manual setting)

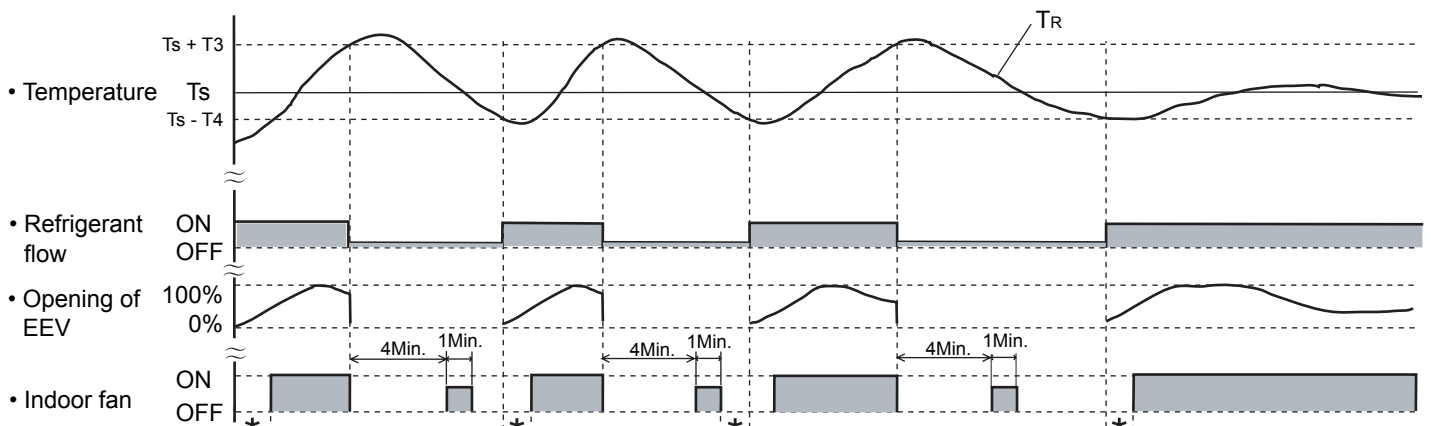

T_s : Corrected setting temperature
 T_R : Corrected room temperature
 $*$: Duration of cold air prevention

$T_s + T3$: The threshold temperature of start of refrigerant flow
 $T_R - T4$: The threshold temperature of stop of refrigerant flow

4-3-5 "FAN" POSITION

- (1) In this position, the fan merely rotates to circulate air, so the room temperature will not change.
- (2) The fan will rotate at a fan speed set with the FAN CONTROL button.
- (3) When only the "FAN" mode is being used, setting the fan speed at "AUTO" is equivalent to setting it at "Low".

4-4 LOUVER CONTROL

(1) ADJUSTING THE DIRECTION OF AIR CIRCULATION

Instructions relating to heating (*) are applicable only to heat pump type outdoor unit.

Begin air conditioner operation before performing this procedure.

Vertical Air Direction Adjustment

This instructions are applicable to "LARGE CEILING TYPE", "UNIVERSAL FLOOR/CEILING TYPE", "CASSETTE TYPE", "WALL MOUNTED TYPE", "COMPACT WALL MOUNTED TYPE" and "CEILING WALL TYPE".

Press the **VERTICAL AIR FLOW DIRECTION SET** button.

Each time the button is pressed, the air direction will change as follows, except for compact wall mounted type indoor units operating under cooling mode.

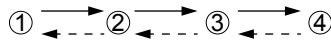

For compact wall mounted type indoor units operating under cooling mode.

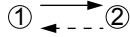

The remote controller's display does not change.

■ LARGE CEILING TYPE

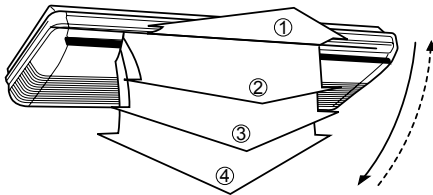

■ UNIVERSAL FLOOR/CEILING TYPE

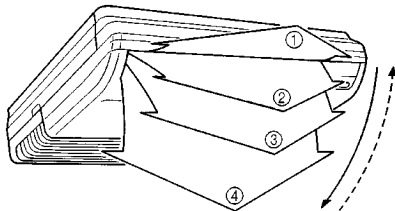

■ CASSETTE TYPE

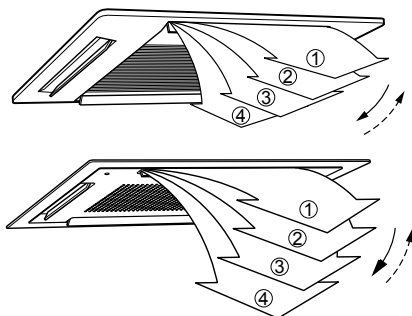

■ WALL MOUNTED TYPE

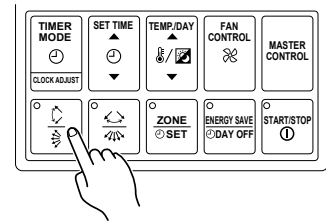
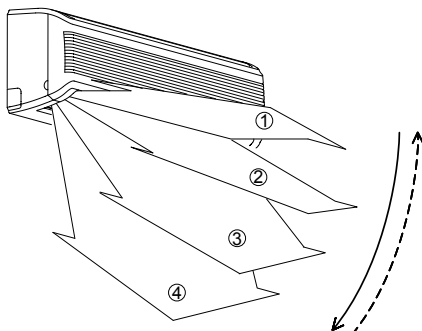

Example : When set to vertical air direction.

⚠ DANGER!

Never place fingers or foreign objects inside the outlet ports, since the internal fan operates at high speed and could cause personal injury.

- Always use the remote control unit's AIR FLOW DIRECTION button to adjust the UP/DOWN air direction flaps or RIGHT/LEFT air direction louvers. Attempting to move them manually could result in improper operation; in this case, stop operation and restart. The louvers should begin to operate properly again.
- During use of the Cooling and Dry modes, do not set the UP/DOWN air direction flaps in the position of ④ (Compact wall mounted type ③&④ for long periods of time, since water vapor may condense near the outlet port and drops of water may drip from the air conditioner.
- When used in a room with infants, children, elderly or sick persons, the air direction and room temperature should be considered carefully when making settings.

■ CEILING WALL TYPE

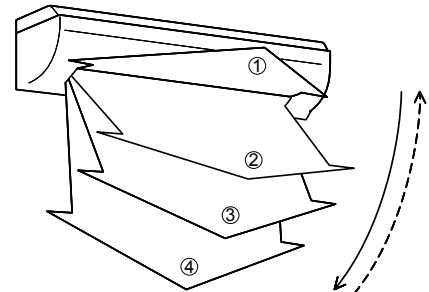

■ COMPACT WALL MOUNTED TYPE

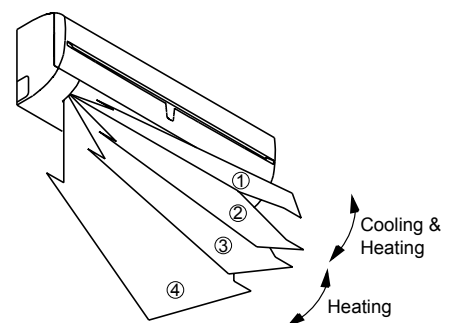

- Use the air direction adjustments within the ranges shown above.
- The vertical airflow direction is set automatically as shown, in accordance with the type of operation selected.
 - During Cooling mode : Horizontal flow ①
 - * During Heating mode : Downward flow ④
- During AUTO mode operation, for the first minute after beginning operation, airflow will be horizontal ①, the air direction cannot be adjusted during this period.

Horizontal Air Direction Adjustment

This instructions are applicable to "LARGE CEILING TYPE", "UNIVERSAL FLOOR/CEILING TYPE", "WALL MOUNTED TYPE" and "CEILING WALL TYPE".

Press the HORIZONTAL AIR FLOW DIRECTION SET button.

Each time the button is pressed, the air direction range will change as follows:

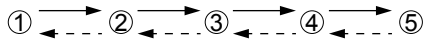

The remote controller's display does not change.

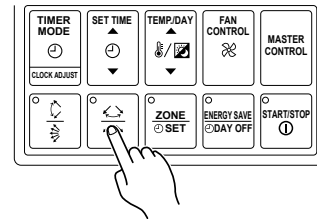

Example : When set to horizontal air direction.

■ LARGE CEILING TYPE

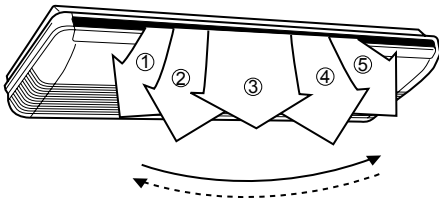

■ WALL MOUNTED TYPE

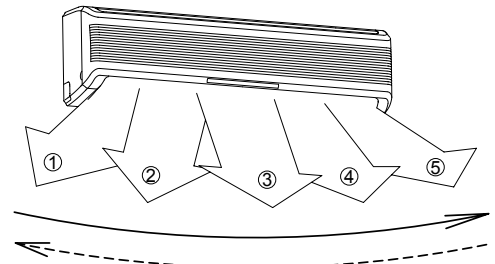

■ UNIVERSAL FLOOR/CEILING TYPE

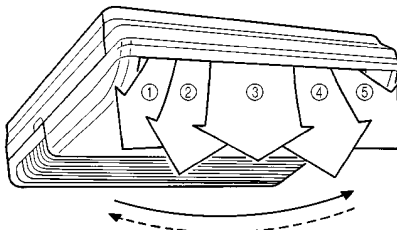

■ CEILING WALL TYPE

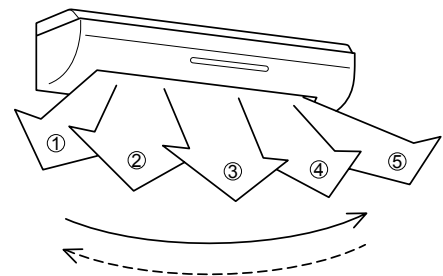

(2) SWING OPERATION

Instructions relating to "the indoor unit's indicator lamp" (**) are applicable to "LARGE CEILING TYPE", "UNIVERSAL FLOOR / CEILING TYPE", "CASSETTE TYPE", "WALL MOUNTED TYPE", "COMPACT WALL MOUNTED TYPE" and "CEILING WALL TYPE".

Begin air conditioner operation before performing this procedure.

To select Vertical airflow SWING Operation

This instructions are applicable to "LARGE CEILING TYPE", "UNIVERSAL FLOOR/CEILING TYPE", "CASSETTE TYPE", "WALL MOUNTED TYPE", "COMPACT WALL MOUNTED TYPE" and "CEILING WALL TYPE".

Press the VERTICAL SWING button for more than two seconds.

The remote controller's VERTICAL SWING lamp (orange) ** and indoor unit's SWING indicator lamp (VERTICAL SWING) (orange) will light up.

In this mode, the UP/DOWN air direction flaps will swing automatically to direct the air flow both up and down.

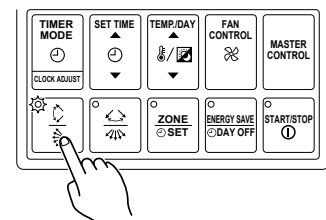

Example : When set to vertical swing.

To Stop Vertical airflow SWING Operation

Press the VERTICAL SWING button for more than two seconds once and again.

The remote controller's VERTICAL SWING lamp **and indoor unit's SWING indicator lamp (VERTICAL SWING) will go out. Airflow direction will return to the setting before swing was begun.

Instructions relating to "the indoor unit's indicator lamp" (**) are applicable to "LARGE CEILING TYPE", "UNIVERSAL FLOOR / CEILING TYPE", "CASSETTE TYPE", "WALL MOUNTED TYPE", "COMPACT WALL MOUNTED TYPE" and "CEILING WALL TYPE".

About Vertical Airflow SWING Operation

- The range of swing is relative to the currently set airflow direction.
- If the swing range is not as desired, use the remote controller's VERTICAL AIR FLOW DIRECTION SET button to change the range of swing.
- The SWING operation may stop temporarily when the air conditioner's fan is not operating, or when operating at very low speeds.

To select Horizontal Airflow SWING Operation

This instructions are applicable to "LARGE CEILING TYPE", "UNIVERSAL FLOOR / CEILING TYPE", "WALL MOUNTED TYPE" and "CEILING WALL TYPE".

Press the HORIZONTAL SWING button for more than two seconds.

The remote controller's HORIZONTAL SWING lamp (orange) **and indoor unit's SWING indicator lamp (HORIZONTAL SWING) (orange) will light up.

In this mode, the RIGHT/LEFT air direction louvers will swing automatically to direct the airflow both right and left.

To stop Horizontal airflow SWING Operation

Press the HORIZONTAL SWING button for more than two seconds once and again.

The remote controller's HORIZONTAL SWING lamp **and indoor unit's SWING indicator lamp (HORIZONTAL SWING) will go out. Airflow direction will return to the setting before swing was begun.

About Horizontal Airflow Swing Operation

- The range of swing is relative to the currently set airflow direction.
- If the swing range is not as desired, use the remote controller's HORIZONTAL AIR FLOW DIRECTION SET button to change the range of swing.
- The SWING operation may stop temporarily when the air conditioner's fan is not operating, or when operating at very low speed.

Air swing range (Expect for compact wall mounted type indoor unit)

Air flow direction set	Range of swing
①	① to ③
②	② to ④
③	② to ④
④	① to ④ (All range)

Air swing range (Compact wall mounted type indoor unit)

Air flow direction set	Range of swing
① or ②	① to ②
③ or ④	③ to ④

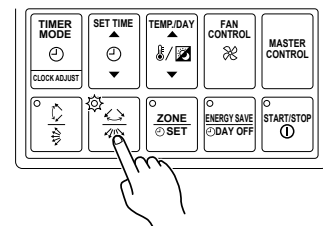

Example : When set to horizontal swing.

Air swing range

Air flow direction set	Range of swing
①	① to ⑤ (All range)
②	① to ③
③	② to ④
④	③ to ⑤
⑤	① to ⑤ (All range)

Air direction range

4-5 ENERGY SAVE OPERATION

(1) About the ENERGY SAVE

- The energy conservation mode (ENERGY SAVE) raises the set temperature slightly in the cooling mode and lowers the set temperature in the heating mode, using a computer program to economically control the operation of the unit.
- If you press the ENERGY SAVE button while the air conditioner is on, it will change to the conservation mode. If you press the ENERGY SAVE button while the unit is in the timer mode (ON timer or WEEKLY timer), the unit will go into the conservation mode when the unit starts with the timer.
- If you turn off the air conditioner while in the conservation mode, the mode will be shut off.

▪ When Heating

After the ENERGY SAVE button is pressed, the set temperature will be lowered about 1°C every 30 minutes. When it has lowered a total of 4°C, then it will hold that temperature.

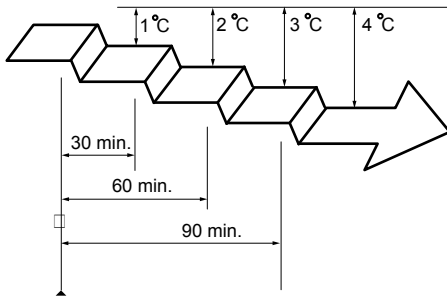

▪ When Cooling

After the ENERGY SAVE button is pressed, the set temperature will be raised about 0.5°C every 30 minutes. When it has gone up a total of 1°C, then it will hold that temperature.

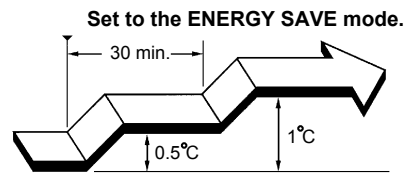

(2) To Use the ENERGY SAVE

Press the ENERGY SAVE button.
The unit will run in the ENERGY SAVE mode.

(3) To Stop the ENERGY SAVE

Press the ENERGY SAVE button one more time.
The ENERGY SAVE mode will be turned off.

The ENERGY SAVE light goes off, and the unit will return to the former operating conditions.

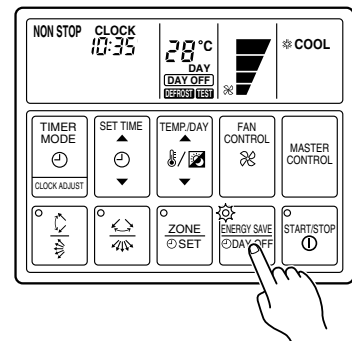

4-6 ANTI FREEZE CONTROL

(1) About the ANTI FREEZE

The freeze prevention function operates when the START/STOP button is pressed and the remote controller is in stop mode (indoor unit is in stop mode). Whenever the room temperature falls to 5°C, it automatically sets the fan to low speed and starts the heating operation. This operation stops when the temperature in the room rises reaches 8°C.

(2) To Use the ANTI FREEZE

Press the VERTICAL AIR FLOW DIRECTION and the HORIZONTAL AIR FLOW DIRECTION SET Button at the same time for more than three seconds. This operation is only enabled with the remote controller set to stop mode.

(3) To Stop the ANTI FREEZE

Press the VERTICAL AIR FLOW DIRECTION and the HORIZONTAL AIR FLOW DIRECTION SET Button at the same time for more than three seconds once again. This operation is only enabled with the remote controller set to stop mode.

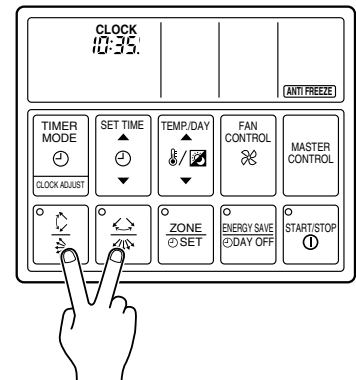

4-7 ELECTRONIC EXPANSION VALVE CONTROL

After the power is turned on, the following operation is controlled automatically to control the most suitable refrigerant charge according to the operation mode and operation conditions of each unit.

Electronic expansion valve control process.

The electronic expansion valve adjusts the opening by selecting the number of pulses from the rated capacity, operation mode (cool / heat) and set temperature of each indoor unit.

When the air conditioner restarts, the " THREE MINUTE DELAY FUNCTION " operates.

4-8 AUTO RESTART

- (1) The air conditioner restarts with the previous setting operation.
- (2) When the air conditioner restarts, the "THREE MINUTE DELAY FUNCTION" operates.
- (3) When the air conditioner restarts for heating operation, the "COLD AIR DISCHARGE PREVENTION FUNCTION" operates.

4-9 DRAIN PUMP OPERATION

- (1) When cooling and refrigerant circulation starts, the drain pump starts simultaneously.
- (2) The drain pump operates continuously for 3 minutes after the refrigerant circulation stopped.
- (3) When the refrigerant circulation is stopped by a start of indoor heat exchanger frost prevention operation, the drain pump will turn off in 1 hour after the end of indoor heat exchanger frost prevention operation.
- (4) When the water level in the drain pan rises up and then the float switch functions:
 - ① Microcomputer stops the refrigerant circulation and indoor fan motor operation.
 - ② Drain pump operates continuously for 3 minutes after the float switch is turned off.
(Almost condensing water may be drained)
- (5) When the float switch turns ON continuously for 3 minutes, 'FAILURE INDICATION' operates.
- (6) When the float switch turns OFF within 3 minutes, the unit starts cooling operation.

Refrigerant
R407C

AIRSTAGE™

5 . TROUBLE SHOOTING

5. TROUBLESHOOTING

5-1 INDOOR UNIT

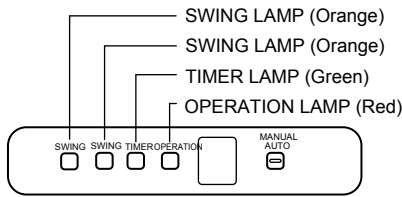

Operation can be checked by lighting and flashing of the LED (OPERATION, TIMER, SWING) of the grille display section. Perform judgment in accordance with the following.







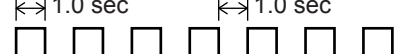

- Test run

When the air conditioner is operating in test run mode, the OPERATION and TIMER lamps flash slowly at the same time.

- Error

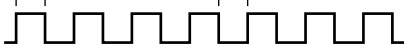
The OPERATION, TIMER and SWING lamps operate as follows (refer to 5-1-2) according to the error contents.

5-1-1 NORMAL OPERATION DISPLAY

OPERATING CONDITION	INDICATOR LAMP	FLASHING PATTERN
Test run	Operation lamp (red) 	ON OFF 
	Timer lamp (green) 	ON OFF 
*1 Stop (Auto-restart disable) DIP SW 2-4 : OFF	Operation lamp (red) 	ON OFF 
	Timer lamp (green) 	ON OFF 
*2 (Defrosting operation (Heating operation) or Oil recovery operation)	Operation lamp (red) 	ON OFF 

Note: Indicator lamps are on the front panel of the indoor unit.

*1: If a power failure occurred, the lamps of operation and timer flash on and off alternately when the power returns.

*2: While the indoor fan motor stops, the operation lamp flashes on and off.

5-1-2 ABNORMAL OPERATION DISPLAY

Error display				Error contents
OPERATION lamp	TIMER lamp	VERTICAL SWING lamp	HORIZONTAL SWING lamp	
0.1sec ON/OFF	0.1 sec ON/OFF	Goes off	Goes off	Model information abnormal
0.1sec ON/OFF	0.1 sec ON/OFF	0.1 sec ON/OFF	0.1 sec ON/OFF	Power supply frequency abnormal
2 times flashing	0.1 sec ON/OFF	Goes off	Goes off	Room temperature thermistor error
3 times flashing	0.1 sec ON/OFF	1 times flashing	Goes off	Indoor unit heat exchanger thermistor (inlet) error
3 times flashing	0.1 sec ON/OFF	2 times flashing	Goes off	Indoor unit heat exchanger thermistor (middle) error
3 times flashing	0.1 sec ON/OFF	3 times flashing	Goes off	Indoor unit heat exchanger thermistor (outlet) error
4 times flashing	0.1 sec ON/OFF	Goes off	Goes off	Drain abnormal
5 times flashing	0.1 sec ON/OFF	1 times flashing	Goes off	Communication error 1 (indoor unit ↔ Wired/Simple remote controller)
5 times flashing	0.1 sec ON/OFF	2 times flashing	Goes off	Microcomputer error
5 times flashing	0.1 sec ON/OFF	4 times flashing	Goes off	Communication error 2 (indoor unit ↔ Wired/Simple remote controller)
6 times flashing	0.1 sec ON/OFF	Goes off	Goes off	Indoor unit fan error
7 times flashing	0.1 sec ON/OFF	Goes off	Goes off	Blower temperature thermistor error
0.1 sec ON/OFF	3 times flashing	3 times flashing	Goes off	Outdoor unit error
0.1 sec ON/OFF	4 times flashing	1 times flashing	Goes off	EEPROM access error
0.1 sec ON/OFF	4 times flashing	2 times flashing	Goes off	EEPROM deletion error
0.1 sec ON/OFF	5 times flashing	1 times flashing	Goes off	Transmission error
0.1 sec ON/OFF	5 times flashing	2 times flashing	Goes off	Node setting error
0.1 sec ON/OFF	6 times flashing	Goes off	Goes off	Parallel communication error
0.1 sec ON/OFF	7 times flashing	Goes off	Goes off	Room temperature abnormal

5-2 OUTDOOR UNIT

5-2-1 NORMAL OPERATING DISPLAY

Display Type	LED 1	LED 2	LED 3	LED 4	LED 5	LED 6
Cooling operation	⊙	○ (1)				
Heating operation	⊙	○ (2)				
Cooling main operation	⊙	○ (3)				
Heating main operation	⊙	○ (4)				
Same performance operation	⊙	○ (5)				
Compressor output STEP1	⊙		○ (1)			
Compressor output STEP2	⊙		○ (2)			
Compressor output STEP4	⊙		○ (3)			
Compressor output STEP5	⊙		○ (4)			
Compressor output STEP6	⊙		○ (5)			
Compressor output STEP7	⊙		○ (6)			
Heat exchanger usage capacity STEP1	⊙			○ (1)		
Heat exchanger usage capacity STEP2	⊙			○ (2)		
Heat exchanger usage capacity STEP3	⊙			○ (3)		
Heat exchanger usage capacity STEP4	⊙			○ (4)		
Heat exchanger usage capacity STEP5	⊙			○ (5)		
Heat exchanger usage capacity STEP6	⊙			○ (6)		
Oil recovery operation	⊙				○ (1)	
Defrosting operation	⊙				○ (2)	
Test run	⊙				○ (3)	
Medium pressure → Low pressure by-pass	⊙					○ (1)
High pressure → Low pressure by-pass	⊙					○ (2)
Under initialization of expansion valve	⊙					⊙

Display Method ⊙ : Lighted continuously
 ○ : 0.5sec ON/0.5sec OFF flashing
 () : Flashing times

Operation display

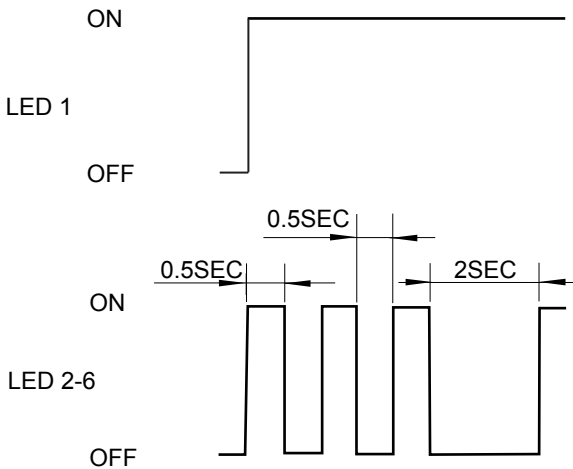

OUTDOOR PRINTED CIRCUIT BOARD LAYOUTS

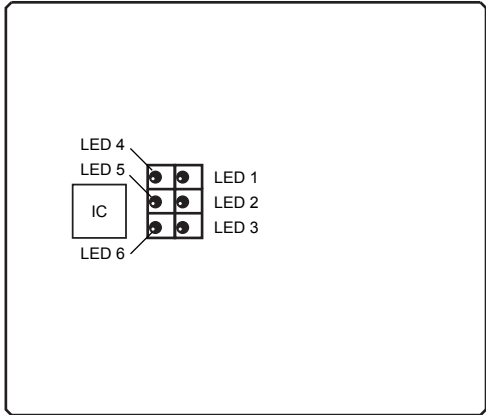

5-2-2 ABNORMAL OPERATION DISPLAY

Display type	LED 1	LED 2	LED 3	LED 4	LED 5	LED 6
Compressor 1 error	◇	● (1)				
Compressor 2 error	◇	● (2)				
Compressor 3 error	◇	● (3)				
Discharge temperature 1 error	◇	● (4)				
Discharge temperature 2 error	◇	● (5)				
Discharge temperature 3 error	◇	● (6)				
High-pressure error	◇	● (7)				
Pump down error	◇	● (9)				
Discharge temperature thermistor 1 error	◇		● (1)			
Discharge temperature thermistor 2 error	◇		● (2)			
Discharge temperature thermistor 3 error	◇		● (3)			
Heat exchange inlet thermistor 1 error	◇		● (4)			
Heat exchange inlet thermistor 2 error	◇		● (5)			
Heat exchange inlet thermistor 3 error	◇		● (6)			
Heat exchange outlet thermistor 1 error	◇		● (7)			
Heat exchange outlet thermistor 2 error	◇		● (8)			
Heat exchange outlet thermistor 3 error	◇		● (9)			
Suction thermistor error	◇		● (10)			
Outdoor thermistor error	◇		● (11)			
Discharge pressure sensor error	◇			● (1)		
Liquid pressure sensor error	◇			● (2)		
Oil recovery error	◇			● (7)		
Reverse phase blocker error	◇		●	◇	● (1)	
Reverse phase blocker error	◇				● (2)	
Power supply frequency abnormal	◇	◇	◇	◇	◇	◇
Model information error	◇				● (3)	
EEPROM access error	◇				● (4)	
EEPROM deletion error	◇				● (6)	
Outdoor unit circuit board error 1	◇				● (7)	
Outdoor unit circuit board error 2	◇					
Outdoor unit circuit board error 2	◇	●		◇		
Transmission error	◇				● (8)	
Node setting error	◇				● (9)	
Indoor unit error	◇					● (1)

Display method {
 ◇ : 0.1 sec ON / 0.1 sec OFF flashing
 ● : 0.3 sec ON / 0.3 sec OFF flashing
 () : Flashing times

Error display

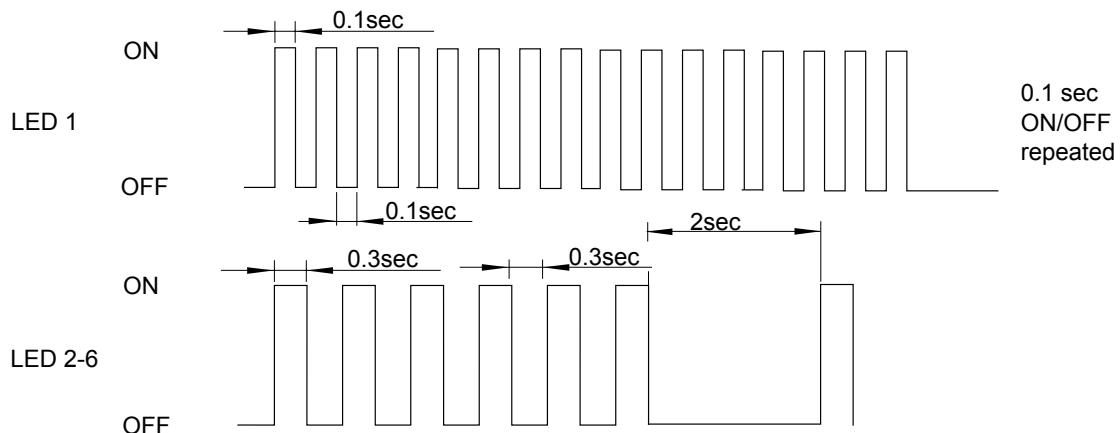

5-3 REMOTE CONTROLLER

5-3-1 WIRED REMOTE CONTROLLER

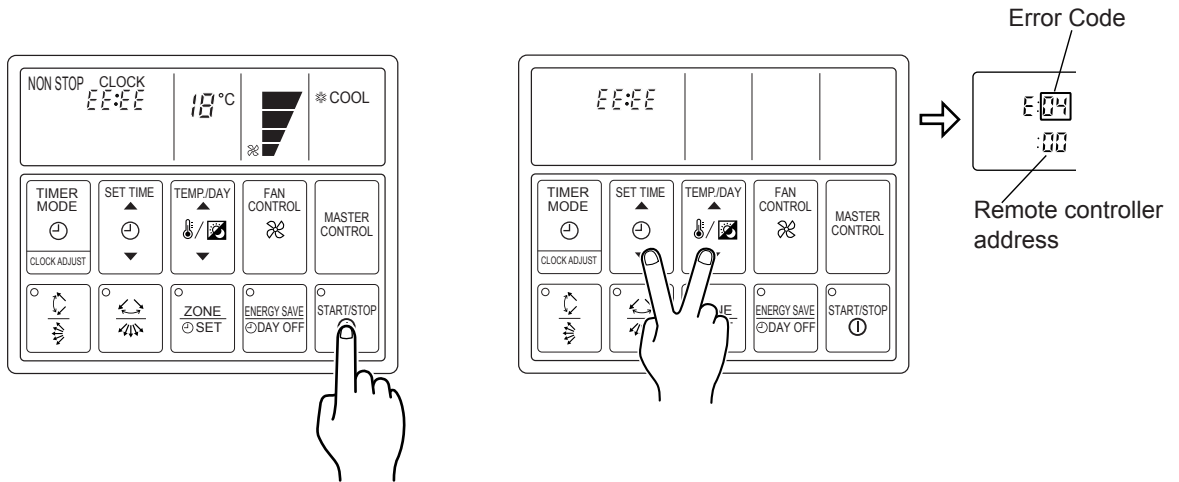

If there is a problem with the air conditioner, it will stop running and " EE:EE " will be displayed instead of the clock.

- (1) If the operation lamp is on then press START/ STOP button to turn it off.
- (2) Press the SET TIMER button (▼) and SET TEMP./DAY button (▼) at the same time for more than three seconds to start the self diagnosis check. An error code will be displayed in the clock display area.
- (3) Press the SET TIMER button (▼) and SET TEMP./DAY button (▼) again for more than three seconds to end the self diagnosis check.

Error code history can be displayed when UTB-*LB type wired remote controllers is used. Please refer to "Installation Instruction Sheet" of the controller.



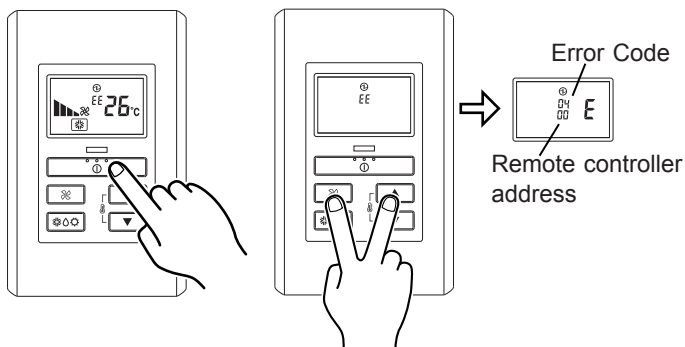

Error code displayed on wired or simple remote controller

Error Code	Error contents
:00	No error
:02	Model information abnormal
:04	Power supply frequency abnormal
:06	EEPROM access error
:07	EEPROM deletion error
:09	Room temperature themistor error
:0A	Indoor unit heat exchanger themistor (middle) error
:0B	Indoor unit heat exchanger themistor (inlet) error
:0C	Indoor unit heat exchanger themistor (outlet) error
:0D	Blower temperature themistor error
:11	Drain abnormal
:12	Room temperature abnormal
:13	Indoor unit fan error
:1F	Transmission error
:20	Node setting error
:21	Parallel communication error
:32	Outdoor unit error

5-3-2 SIMPLE REMOTE CONTROLLER



If there is a problem with the air conditioner it will stop running and " EE:EE " will be displayed.

- (1) If the operation lamp is on then press  button to turn it off.
- (2) Press the  and the  buttons at the same time for more than three seconds to start the self diagnosis check. An error code will be displayed display area.
- (3) Press the  and the  buttons again for more than three seconds to end the self diagnosis check.

Error code history can be displayed. Please refer to "Installation Instruction Sheet" of the remote controller.

5-3-3 CENTRAL REMOTE CONTROLLER

If the **ERROR** and the number for the central control number **00** flash during operation, there is an error at the relevant remote control group. Start the error monitor, identify the error and remove the cause.

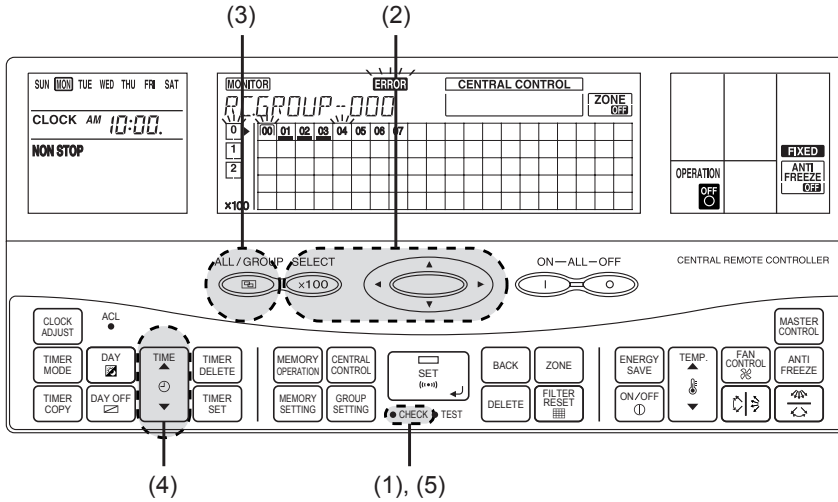

When the error monitor is started, the following can be performed.

The error code for each remote control group (indoor units) is displayed.

Up to two of the past error codes are displayed for each of the indoor units, the outdoor units and the central remote controller group.

- (1) Press ● CHECK to start the error monitor.
The LCD changes to the error monitor screen.

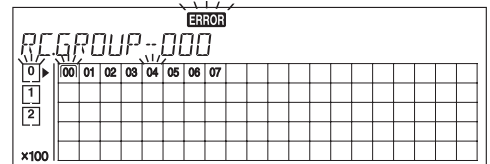

- (2) Press to select the central control number for which its details of the error contents are to be confirmed. (The number of the **00** causing the error is flashing.)

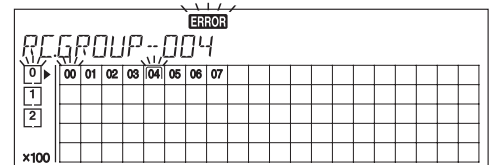

- (3) Press to select the display mode for the error code.
Each press of will switch the display as shown below.

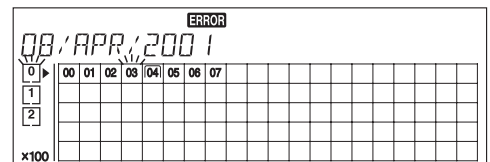

▶ Current error code → First previous error code → Second previous error code

(4) Press  to select the indoor units in the remote control group selected in 3.

Continue pressing , the error codes for the outdoor unit and the central remote controller are displayed. Each of the displays is shown below.

Indoor unit error display

SUN	MON	TUE	WED	THU	FRI	SAT
ADDRESS 00:01						
09:E						
--:E						

"The refrigerant system address and indoor unit address are displayed."



Outdoor unit error display

SUN	MON	TUE	WED	THU	FRI	SAT
ADDRESS 00:-0						
21:E						
--:E						

"Refrigerant system address" and "-0" are displayed.





Central remote control error display

SUN	MON	TUE	WED	THU	FRI	SAT
ADDRESS C:00						
01:E						
--:E						

The "C" code and the central remote controller address are displayed.



- If there have been multiple errors for one unit, continually pressing will  display the error codes in sequence. When all the error codes have been displayed, the display will switch to the next unit.
- If there is no error in the central control number selected in 3, the display will not change when  is pressed. "00" displayed means "no errors".

(5) Press ● CHECK again to end the error monitor.

MONITOR	ERROR	CENTRAL CONTROL	ZONE 000															
RC GROUP: 000																		
0	00	01	02	03	04	05	06	07										
1																		
2																		
x100																		









Error code displayed on central remote controller

Error Code	Indoor unit error	Outdoor unit error	Central remote controller
00	No error	No error	No error
01	–	–	–
02	Model information abnormal	Model information error	Printed circuit board error (Control panel)
03	Microcomputer communication error	Microcomputer communication error	Printed circuit board error (Transmission adaptor)
04	Power supply frequency abnormal	Power supply frequency abnormal	Memory error
05	–	Reverse phase blocker error	Node setting error
06	EEPROM access error	EEPROM access error	Parallel communication error
07	EEPROM deletion error	–	–
08	–	–	–
09	Room temperature thermistor error	Compressor 1 error	–
0A	Heat exchanger thermistor (middle) error	Compressor 2 error	–
0B	Heat exchanger thermistor (inlet) error	Compressor 3 error	–
0C	Heat exchanger thermistor (outlet) error	–	–
0D	Blower temperature thermistor error	Discharge temperature thermistor 1 error	–
0E	–	Discharge temperature thermistor 2 error	–
0F	–	Discharge temperature thermistor 3 error	–
10	–	Outdoor temperature thermistor error	–
11	Drain abnormal	Heat exchanger inlet thermistor 1 error	–
12	Room temperature abnormal	Heat exchanger inlet thermistor 2 error	–
13	Indoor unit fan error	Heat exchanger inlet thermistor 3 error	–
14	–	Heat exchanger outlet thermistor 1 error	–
15	–	Heat exchanger outlet thermistor 2 error	–
16	–	Heat exchanger outlet thermistor 3 error	–
17	–	Suction thermistor error	–
18	Standard wired remote controller communication error 1,2	–	–
19	–	Discharge pressure sensor error	–
1A	–	Liquid pressure sensor error	–
1B	–	Suction pressure sensor error	–
1C	–	–	Connection error
1D	–	–	Initial setting error
1E	–	–	Manual storing 2 error
1F	Transmission error	Transmission error	Transmission error
20	–	–	–
21	–	Discharge temperature 1 error	Software error (Output)
22	–	Discharge temperature 2 error	Software error (Input)
23	–	Discharge temperature 3 error	–
24	–	High-pressure error	–
25	–	Low-pressure error	–
26	–	–	–
27	–	–	–
28	–	Pump down error	–

5-4 NETWORK CONVERTOR

If there is a problem with the network convertor(UTR-YSSA), an error code will appear on D129 of print circuit board.

Error code displayed on network convertor

Error code	Error contents
	No error (operation mode)
	Initial setting
	Circuit board error 1
	Circuit board error 2
	Transmission error with wired RC
	Transmission error with indoor unit
	Transmission error with VRF system
	Software error
	Indoor or outdoor unit error

5-5 ERROR CODE & TROUBLESHOOTING

5-5-1 TROUBLE SHOOTING WITH ERROR CODE

■ INDOOR UNIT TROUBLESHOOTING

ERROR CODE	ERROR	ERROR CONTENTS	CAUSE	COUNTERMEASURE
00	No errors			
02	Model information error	<ol style="list-style-type: none"> 1. Error occurrence condition When power is turned on. Error for the model information, which is memorized in EEPROM, occurs. 2. Relevant operation <ol style="list-style-type: none"> 1) Relevant indoor unit is stopped (Not started). 2) Error is displayed on LED of indoor unit or output to communication bus line. 3. Clearance □ □ Model information, which is memorized in EEPROM is recovered normally. 	Model information is not memorized or erased because of some reason.	Replace control printed circuit board of indoor unit.
03	Microcomputer communication error	<ol style="list-style-type: none"> 1. Error occurrence condition Communication between two microcomputers on indoor unit control printed circuit board is not performed correctly. 2. Relevant operation <ol style="list-style-type: none"> 1) Relevant indoor unit is stopped (not started). 2) Error is displayed on LED of indoor unit or output to communication bus line. 3. Clearance The communication between microcomputers is performed correctly. 	<ol style="list-style-type: none"> 1. Effect of extraneous noise 2. Control printed circuit board of Indoor unit is faulty. 	<ol style="list-style-type: none"> 1. When power is turned off, and then turned on again: <ol style="list-style-type: none"> 1) If error doesn't occur, printed circuit board is normal. Then, remove noise sources near indoor unit. 2) If error occurs again, remove noise sources and take measure with the following countermeasure No.2. 2. Replace indoor unit control printed circuit board.
04	Power supply frequency abnormal	<ol style="list-style-type: none"> 1. Error occurrence condition When control printed circuit board of Indoor unit detects frequency, which is not specified. 2. Relevant operation <ol style="list-style-type: none"> 1) Relevant indoor unit is stopped (not started). 2) Error is displayed on LED of indoor unit or output to communication bus line. 3. Clearance Control printed circuit board of Indoor unit detects the specified frequency. 	Power supply frequency is in the following range. Lower than 45Hz or Higher than 65Hz.	Check power supply frequency and apply the power whose frequency is within the specified frequency.
06	EEPROM access error	<ol style="list-style-type: none"> 1. Error occurrence condition After indoor unit operation is started, EEPROM cannot be accessed because of disturbance or device error. 2. Relevant operation Error is displayed on LED of indoor unit. 3. Clearance Access to EEPROM is performed correctly. 	EEPROM cannot be accessed because of disturbance, device error, etc.	<ol style="list-style-type: none"> 1. Remove noise sources near indoor unit. 2. Replace control printed circuit board of indoor unit.

ERROR CODE	ERROR	ERROR CONTENTS	CAUSE	COUNTERMEASURE
07	EEPROM deletion error	<ol style="list-style-type: none"> 1. Error occurrence condition After indoor unit operation is started, error for model information, which is memorized on EEPROM, occurs. 2. Relevant operation 1) Relevant indoor unit is stopped. 2) Error is displayed on LED of indoor unit. 3. Clearance Model information, which is memorized on EEPROM is recovered. 	Model information is not memorized, or erased because of some reasons.	Replace control printed circuit board of indoor unit.
09	Room temperature thermistor error	<ol style="list-style-type: none"> 1. Error occurrence condition The condition of thermistor, which is short or open, is detected. 2. Relevant operation Indoor unit stopped. Error is displayed on LED of indoor unit and output to communication bus line. 3. Clearance Thermistor detection is other than short or open. 	<ol style="list-style-type: none"> 1. Connector connection is faulty. 2. Room Temperature thermistor is faulty. 	<ol style="list-style-type: none"> 1. Check if the connector of Room temperature thermistor loosens or comes off. 2. Check the resistance of Room temperature thermistor. If it's not normal, replace the thermistor.
0A	Heat exchanger thermistor (middle) error	<ol style="list-style-type: none"> 1. Error occurrence condition The condition of thermistor, which is short or open, is detected. 2. Relevant operation Indoor unit is stopped. Error is displayed on LED of indoor unit and output to communication bus line. 3. Clearance Thermistor detection is other than short or open. 	<ol style="list-style-type: none"> 1. Connector connection is faulty. 2. Heat exchanger thermistor (middle) is faulty. 	<ol style="list-style-type: none"> 1. Check if the connector of Heat exchanger thermistor (middle) loosens or comes off. 2. Check the resistance of heat exchanger thermistor (middle). If it's not normal, replace thermistor.
0B	Heat exchanger thermistor (inlet) error	<ol style="list-style-type: none"> 1. Error occurrence condition The condition of thermistor, which is short or open, is detected. 2. Relevant operation Error is displayed on LED of indoor unit. 3. Clearance Thermistor detection is other than short or open. 	<ol style="list-style-type: none"> 1. Connector connection is faulty. 2. Heat exchanger thermistor (inlet) is faulty. 	<ol style="list-style-type: none"> 1. Check if the connector of heat exchanger thermistor (inlet) loosens or comes off. 2. Check the resistance of heat exchanger thermistor (inlet). If it's not normal, replace thermistor.
0C	Heat exchanger thermistor (outlet) error	<ol style="list-style-type: none"> 1. Error occurrence condition The condition of thermistor, which is short or open, is detected. 2. Relevant operation Error is displayed on LED of indoor unit. 3. Clearance Thermistor detection is other than short or open. 	<ol style="list-style-type: none"> 1. Connector connection is faulty. 2. Heat exchanger thermistor (outlet) is faulty. 	<ol style="list-style-type: none"> 1. Check if the connector of heat exchanger thermistor (outlet) loosens or comes off. 2. Check the resistance of heat exchanger thermistor (outlet). If it's not normal, replace thermistor.

ERROR CODE	ERROR	CONTENTS	CAUSE	COUNTERMEASURE
0D	Blower temperature thermistor error	<ol style="list-style-type: none"> 1. Error occurrence condition The condition of thermistor, which is short or open, is detected. 2. Relevant operation Indoor unit is stopped. Error is displayed on LED of indoor unit and output to communication bus line. 3. Clearance Thermistor detection is other than short or open. 	<ol style="list-style-type: none"> 1. Connector connection is faulty. 2. Blower temperature thermistor is faulty. 	<ol style="list-style-type: none"> 1. Check if the connector of blower temperature thermistor loosens or comes off. 2. Check resistance of blower temperature thermistor. If it's not normal, replace thermistor.
11	Drain abnormal	<ol style="list-style-type: none"> 1. Error occurrence condition Float SW is ON continuously for 3 minutes. 2. Relevant operation Indoor unit is stopped. Error is displayed on LED of indoor unit and output to communication bus line. 3. Clearance Float SW is OFF. 	<ol style="list-style-type: none"> 1. Drain hose is clogged. 2. Drain outlet is clogged. 3. Drain pump is faulty. 4. Float SW operation is faulty (short) 	<ol style="list-style-type: none"> 1. Clean drain hose. 2. Clean drain outlet. 3. Check drain pump operation. If it's faulty, replace pump. 4. If float SW is shorted, replace SW.
12	Room temperature abnormal	<ol style="list-style-type: none"> 1. Error occurrence condition Room temperature thermistor detects higher than 60°C continuously for 30 minutes or longer during indoor unit operation. 2. Relevant operation Indoor unit is stopped. Error is displayed on LED of indoor unit and output to communication bus line. 3. Clearance It's cleared by turning off the power . 	<ol style="list-style-type: none"> 1. Connector connection is faulty. 2. Room temperature thermistor is faulty. 	<ol style="list-style-type: none"> 1. Check if the connector of room temperature thermistor loosens or comes off. 2. Check resistance of room temperature thermistor. If it's normal, replace thermistor.
13	Indoor unit fan error	<ol style="list-style-type: none"> 1. Error occur condition Fan speed feedback of large ceiling type, slim body cassette type and ceiling wall type is lower than 1/3 of target speed. 2. Relevant operation Indoor fan is stopped, error is displayed on LED of indoor unit and out put to communication bus line. 3. Clearance It's cleared by turning off the power. 	<ol style="list-style-type: none"> 1. Indoor fan motor lead wire connection is faulty. 2. Power supply voltage abnormal. 	<ol style="list-style-type: none"> 1. Check the wiring of indoor fan motor lead wire . 2. Check if rated power supply voltage is applied.
18	Standard wired R.C. communication error 1,2	<ol style="list-style-type: none"> 1. Error occurrence condition Communication can not be performed between standard wired remote controller and indoor unit or between indoor units in same remote controller group for a certain time. 2. Relevant operation Error is displayed on LED of indoor unit. 3. Clearance Standard wired remote controller communication is recovered. 	<ol style="list-style-type: none"> 1. Communication line is not connected, connection fault, or disconnection. 2. Indoor unit control printed circuit board is faulty. 3. Standard wired remote controller printed circuit board is faulty. 	<ol style="list-style-type: none"> 1. Check if communication line is connected to each indoor unit. Check if communication line is disconnected or loosen. 2. Replace control printed circuit board of indoor unit. 3. Replace standard wired remote controller printed circuit board.

ERROR COCE	ERROR	ERROR CONTENTS	CAUSE	COUNTERMEASURE
1F	Transmission error	<p>1. Error occurrence condition Communication between indoor unit and outdoor unit cannot be performed for a certain time.</p> <p>2. Relevant operation Current operation is continued. Error is displayed on standard wired remote controller, and displayed on indoor unit LED.</p> <p>3. Clearance Communication between indoor unit and outdoor unit is recovered.</p>	<p>1. Effect of extraneous noise.</p> <hr/> <p>2. Communication line is not connected, connection fault, or disconnection.</p> <hr/> <p>3. Insertion for communication printed circuit board of indoor unit or outdoor unit is faulty.</p> <hr/> <p>4. Printed circuit board is faulty.</p>	<p>1. When power is turned OFF and turned ON again:</p> <p>1) If error doesn't occur, printed circuit board is normal. Then, remove noise sources near outdoor unit.</p> <p>2) If error occurs again, remove noise sources and take measure with the following countermeasure No.2-4.</p> <hr/> <p>2. Check if communication line is connected to all indoor unit. Check if communication line is disconnected.</p> <hr/> <p>3. Check the insertion of indoor unit communication printed circuit board and outdoor unit communication printed circuit board.</p> <hr/> <p>4. 1) If communication of some indoor units in same refrigerant system is abnormal and the compressor operates, replace printed circuit boards with following procedures and check the operation:</p> <p>① Replace Indoor unit communication printed circuit board.</p> <p>② Replace Indoor unit control printed circuit board.</p> <p>2) If communication of all indoor units in same refrigerant system is abnormal and the compressor does not operate, replace printed circuit boards with following procedures and check the operation:</p> <p>① Replace Outdoor unit communication printed circuit board.</p> <p>② Replace Outdoor unit control printed circuit board.</p> <p>③ Replace Indoor unit communication printed circuit board.</p> <p>④ Replace Indoor unit control printed circuit board.</p>
20	Node setting error	<p>1. Error occurrence condition Indoor unit communication printed circuit board is not initialized normally.</p> <p>2. Relevant operation Error is displayed on standard wired remote controller and displayed on LED of indoor unit.</p> <p>3. Clearance Indoor unit communication printed circuit board is initialized correctly.</p>	<p>1. Effect of extraneous noise.</p> <hr/> <p>2. Printed circuit board is faulty.</p>	<p>1. When power turned OFF and turned ON again:</p> <p>1) If error doesn't occur, printed circuit board is normal. Then, remove noise sources near indoor unit.</p> <p>2) If error occurs again, remove noise sources and take measure with the following countermeasure No.2-3.</p> <hr/> <p>2. Replace printed circuit boards with following procedures, and check the operation.</p> <p>① Replace Indoor unit communication printed circuit board.</p> <p>② Replace Indoor unit control printed circuit board.</p>

ERROR CODE	ERROR	ERROR CONTENTS	CAUSE	COUNTERMEASURE
21	Parallel communication error	<p>1. Error occurrence condition Communication between indoor unit control printed circuit board and indoor unit communication printed circuit board is not performed normally.</p> <p>2. Relevant operation</p> <p>1) Current operation is continued. Error is displayed on standard wired remote controller, and displayed on LED of indoor unit.</p> <p>2) If error continues for 90 seconds after it's occurrence, a new transmission error (1F) is output.</p> <p>3. Clearance Communication is performed correctly between indoor unit control printed circuit board and indoor unit communication printed circuit board.</p>	<p>1. Effect of extraneous noise.</p> <hr style="border-top: 1px dashed black;"/> <p>2. Indoor unit communication board insertion is faulty.</p> <hr style="border-top: 1px dashed black;"/> <p>3. Printed circuit board is faulty.</p>	<p>1. When power is turned OFF and turned ON again:</p> <p>1) If error doesn't occur, printed circuit board is normal. Then, remove noise sources near indoor unit.</p> <p>2) If error occurs again, remove noise sources and take measure with the following countermeasure No.2-3.</p> <hr style="border-top: 1px dashed black;"/> <p>2. Check the insertion of indoor unit communication printed circuit board.</p> <hr style="border-top: 1px dashed black;"/> <p>3. Replace printed circuit boards with following procedure, and check the operation.</p> <p>(1) Replace Indoor unit communication printed circuit board.</p> <p>(2) Replace Indoor unit control printed circuit board.</p>
32	Outdoor unit error	Error occurs on outdoor unit in same refrigerant system.	Outdoor unit is faulty.	See "Outdoor unit troubleshooting".

■ OUTDOOR UNIT TROUBLESHOOTING

ERROR CODE	ERROR	ERROR CONTENTS	CAUSE	COUNTERMEASURE
00	No errors			
02	Model information error	<ol style="list-style-type: none"> 1. Error occurrence condition When power is turned on, error occurs in model information, which is memorized in EEPROM. 2. Relevant operation <ol style="list-style-type: none"> 1) All compressors are stopped (not started). 2) Error is displayed on LED of outdoor unit and output to communication bus line. 3. Clearance Model information, which is memorized in EEPROM is recovered. 	Model information is not memorized, or erased because of some reason.	Replace outdoor unit control printed circuit board.
03	Circuit board error	<ol style="list-style-type: none"> 1. Error occurrence condition Communication between two microcomputers on outdoor unit control printed circuit board is not performed normally. 2. Relevant operation <ol style="list-style-type: none"> 1) All compressors is stopped (not started). 2) Error is displayed on LED of outdoor unit and output to communication bus line. 3. Clearance Communication between microcomputers is recovered. 	1. Effect of extraneous noise	<ol style="list-style-type: none"> 1. When power is turned OFF and turned ON again: <ol style="list-style-type: none"> 1) If error doesn't occur, printed circuit board is normal. Then, remove noise sources near outdoor unit. 2) If error occurs again, remove noise sources and take measure with the following countermeasure No.2.
			2. Outdoor unit control printed circuit board is faulty.	2. Replace outdoor unit control printed circuit board.
04	Power supply frequency abnormal	<ol style="list-style-type: none"> 1. Error occurrence condition Outdoor unit control printed circuit board detects frequency outside of rating. 2. Relevant operation <ol style="list-style-type: none"> 1) All compressors are stopped (not started). 2) Error is displayed on LED of outdoor unit and output to communication bus line. 3. Clearance Outdoor unit control printed circuit board detects the specified frequency. 	Power supply frequency is in the following range. Lower than 45Hz or higher than 65Hz.	Check power supply frequency and apply the power whose frequency is within the specified frequency.
05	Reverse phase blocker error	<ol style="list-style-type: none"> 1. Error occurrence condition Reverse phase prevention circuit detects the wrong phase of power supply or the correct power supply input is not detected. 2. Relevant operation <ol style="list-style-type: none"> 1) All compressors are stopped. 2) Error is displayed on LED of outdoor unit and output to communication bus line. 3. Clearance Reverse phase prevention circuit doesn't detect reverse phase input. 	1. Reverse phase wiring.	1. Check power supply wiring.
			2. Reverse phase prevention circuit is faulty.	2. Check power supply wiring. If there are no mistakes, replace outdoor unit control printed circuit board.

ERROR CODE	ERROR	ERROR CONTENTS	CAUSE	COUNTERMEASURE
06	EEPROM access error	<ol style="list-style-type: none"> 1. Error occurrence condition After outdoor unit operation is started, EEPROM cannot be accessed because of disturbance or device error. 2. Relevant operation Error is displayed on LED of outdoor unit. *Outdoor unit operation is not controlled. 3. Clearance EEPROM can be accessed correctly. 	EEPROM cannot be accessed because of disturbance, device error, etc.	<ol style="list-style-type: none"> 1. Remove noise sources near outdoor unit. 2. Replace outdoor unit control printed circuit board.
07	EEPROM deletion error	<ol style="list-style-type: none"> 1. Error occurrence condition After outdoor unit operation is started, error occurs in model information, which is memorized in EEPROM. 2. Relevant operation 1) All compressors are stopped. 2) Error is displayed on LED of outdoor unit. 3. Clearance Model information, which is memorized in EEPROM is recovered. 	Model information is not memorized, or erased for some reason.	Replace outdoor unit control printed circuit board.
09	Compressor 1 error	<ol style="list-style-type: none"> 1. Error occurrence condition After thirty minutes has elapsed since compressor 1 starts to work, discharge temperature 1 does not reach to outdoor temperature plus 10 °C. 2. Relevant operation 1) After compressor error occurs, compressor recovery operation is performed. However, if defrosting control or oil recovery operation is performed, compressor recovery is not operated. 2) Error is displayed on LED of outdoor unit and output to communication bus line. 3. Clearance When 2 hours have elapsed after error occurrence. *Counting of 2-hour counter starts if error occurs on any compressors. Error is cleared by turning power off. 	<ol style="list-style-type: none"> 1. Discharge temperature sensor TH_{D1} is faulty. 2. Compressor power relay 1 is faulty. 3. Outdoor unit control printed circuit board is faulty. 4. Magnetic contactor 1 is faulty. 5. Lack of refrigerant. 6. After 2 and half an hours have elapsed since error is displayed, error detection is performed again and error is not displayed. 7. Compressor motor protector is operated. 8. Compressor is faulty. 	<ol style="list-style-type: none"> 1. Check if the wiring of discharge temperature sensor TH_{D1} loosens or comes off. And check the resistance of sensor. If it's abnormal, replace sensor. 2. Check compressor power relay 1. If it's abnormal, replace power relay. 3. Check CN24 (compressor 1) 12V voltage output on outdoor unit control printed circuit board. If it's abnormal, replace printed circuit board. 4. Check magnetic contactor 1. If it's abnormal, replace contactor. 5. Check additional refrigerant amount and recharge suitable refrigerant. 6. Temporary data transmission trouble due to Effect of extraneous noise, etc. Operation is not affected. 7. Compressor overload operation Check "High-pressure error". Motor protector is reset at 61 °C +/-9 °C. 8. Check compressor. If it's faulty, replace compressor.

ERROR CODE	ERROR	CONTENTS	CAUSE	COUNTERMEASURE
0A	Compressor 2 error	<p>1. Error occurrence condition After thirty minutes have elapsed since compressor 2 starts to work, discharge temperature 2 does not reach to outdoor temperature plus 10 °C.</p> <p>2. Relevant operation 1) After compressor error occurs, compressor recovery operation is performed. However, if defrosting control or oil recovery operation is performed, compressor recovery is not operated. 2) Error is displayed on LED of outdoor unit and output to communication bus line. 3. Clearance When 2 hours have elapsed after error occurrence. *Counting of 2-hour counter starts if error occurs on any compressors. Error is cleared by turning power off.</p>	1. Discharge temperature sensor TH _{D2} is faulty.	1. Check if the wiring of discharge temperature sensor TH _{D2} loosens or comes off. And check the resistance of sensor. If it's abnormal, replace sensor.
			2. Compressor power relay 2 is faulty.	2. Check compressor power relay 2. If it's abnormal, replace power relay.
			3. Outdoor unit control printed circuit board is faulty.	3. Check CN25 (compressor 2) 12V voltage output on outdoor unit control printed circuit board. If it's abnormal, replace printed circuit board.
			4. Magnetic contactor 2 is faulty.	4. Check magnetic contactor 2. If it's abnormal, replace contactor.
			5. Lack of refrigerant.	5. Check additional refrigerant amount and recharge suitable refrigerant.
			6. After 2 and half an hours have elapsed since error is displayed, error detection is performed again and error is not displayed.	6. Temporary data transmission trouble due to affect of noise, etc. Operation is not affected.
			7. Compressor motor protector is operated.	7. Compressor overload operation Check "High-pressure error". Motor protector is reset at 61°C +/-9°C.
			8. Compressor is faulty.	8. Check compressor. If it's faulty, replace compressor.
0B	Compressor 3 error	<p>1. Error occurrence condition After thirty minutes have elapsed since compressor 3 starts to work, discharge temperature 3 does not reach to outdoor temperature plus 10 °C.</p> <p>2. Relevant operation 1) After compressor error occurs, compressor recovery operation is performed. However, if defrosting control or oil recovery operation is performed, compressor recovery is not operated. 2) Error is displayed on LED of outdoor unit and output to communication bus line. 3. Clearance When 2 hours has elapsed after error occurrence. *Counting of 2-hour counter starts if error occurs on any compressors. Error is cleared by turning power off.</p>	1. Discharge temperature sensor TH _{D3} is faulty.	1. Check if the wiring of discharge temperature sensor TH _{D3} loosens or comes off. And check the resistance of sensor. If it's abnormal, replace sensor.
			2. Compressor power relay 3 is faulty.	2. Check compressor power relay 3. If it's abnormal, replace power relay.
			3. Outdoor unit control printed circuit board is faulty.	3. Check CN26 (compressor 3) 12V voltage output on outdoor unit control printed circuit board. If it's abnormal, replace printed circuit board.
			4. Magnetic contactor 3 is faulty.	4. Check magnetic contactor 3. If it's abnormal, replace contactor.
			5. Lack of refrigerant.	5. Check additional refrigerant amount and recharge suitable refrigerant.
			6. After 2 and half an hours have elapsed since error is displayed, error detection is performed again and error is not displayed.	6. Temporary data transmission trouble due to affect of noise, etc. Operation is not affected.
			7. Compressor motor protector is operated.	7. Compressor overload operation Check "High-pressure error". Motor protector is reset at 61° C +/-9° C.
			8. Compressor is faulty.	8. Check compressor. If it's faulty, replace compressor.

ERROR CODE	ERROR	CONTENTS	CAUSE	COUNTERMEASURE
0D	Discharge temperature thermistor 1 error	<p>1. Error occurrence condition Thermistor condition, which is short or open, is detected.</p> <p>2. Relevant operation</p> <p>1) Compressor 1 is stopped.</p> <p>2) Error is displayed on LED of outdoor unit and output to communication bus line.</p> <p>3. Clearance Thermistor detection is other than short or open. *Detection is performed when Compressor continues to operate for 5 minutes or longer.</p>	<p>1. Connector contact is faulty.</p> <hr/> <p>2. Discharge temperature thermistor TH_{D1} is faulty.</p>	<p>1. Check if the connector of discharge temperature thermistor TH_{D1} loosens or comes off.</p> <hr/> <p>2. Check the resistance of discharge temperature thermistor TH_{D1}. If it's abnormal, replace thermistor.</p>
0E	Discharge temperature thermistor 2 error	<p>1. Error occurrence condition Thermistor condition, which is short or open, is detected.</p> <p>2. Relevant operation</p> <p>1) Compressor 2 is stopped.</p> <p>2) Error is displayed on LED of outdoor unit and output to communication bus line.</p> <p>3. Clearance Thermistor detection is other than short or open. *Detection is performed when Compressor continues to operate for 5 minutes or longer.</p>	<p>1. Connector contact is faulty.</p> <hr/> <p>2. Discharge temperature thermistor TH_{D2} is faulty.</p>	<p>1. Check if the connector of discharge temperature thermistor TH_{D2} loosens or comes off.</p> <hr/> <p>2. Check the resistance of discharge temperature thermistor TH_{D2}. If it's abnormal, replace thermistor.</p>
0F	Discharge temperature thermistor 3 error	<p>1. Error occurrence condition Thermistor condition, which is short or open, is detected.</p> <p>2. Relevant operation</p> <p>1) Compressor 3 is stopped.</p> <p>2) Error is displayed on LED of outdoor unit and output to communication bus line.</p> <p>3. Clearance Thermistor detection is other than short or open. *Detection is performed when Compressor continues to operate for 5 minutes or longer.</p>	<p>1. Connector contact is faulty.</p> <hr/> <p>2. Discharge temperature thermistor TH_{D3} is faulty.</p>	<p>1. Check if the connector of discharge temperature thermistor TH_{D3} loosens or comes off.</p> <hr/> <p>2. Check the resistance of discharge temperature thermistor TH_{D3}. If it's abnormal, replace thermistor.</p>

ERROR CODE	ERROR	CONTENTS	CAUSE	COUNTERMEASURE
10	Outdoor thermistor error	1. Error occurrence condition Each thermistor condition, which is short or open, is detected. 2. Relevant operation 1) All Compressors are stopped.	1. Connector contact is faulty. 2. Outdoor temperature thermistor TH _{H0} is faulty.	1. Check if the connector of outdoor temperature thermistor TH _{H0} loosens or comes off. 2. Check the resistance of outdoor temperature thermistor TH _{H0} . If it's abnormal, replace thermistor.
11	Heat exchanger inlet thermistor 1 error	*For suction temperature thermistor error, compressors are not stopped. 2) Error is displayed on LED of outdoor unit and output to communication bus line.	1. Connector contact is faulty. 2. Heat exchanger inlet thermistor TH _{H11} is faulty.	1. Check if the connector of heat exchanger inlet thermistor TH _{H11} loosens or comes off. 2. Check the resistance of heat exchanger inlet thermistor TH _{H11} . If it's abnormal, replace thermistor.
12	Heat exchanger inlet thermistor 2 error	*For suction temperature thermistor error, error is only displayed on LED of outdoor unit.	1. Connector contact is faulty. 2. Heat exchanger inlet thermistor TH _{H12} is faulty.	1. Check if the connector of heat exchanger inlet thermistor TH _{H12} loosens or comes off. 2. Check the resistance of heat exchanger inlet thermistor TH _{H12} . If it's abnormal, replace thermistor.
13	Heat exchanger inlet thermistor 3 error	3. Clearance Thermistor detection is other than short or open.	1. Connector contact is faulty. 2. Heat exchanger inlet thermistor TH _{H13} is faulty.	1. Check if the connector of heat exchanger thermistor TH _{H13} loosens or comes off. 2. Check the resistance of heat exchanger inlet thermistor TH _{H13} . If it's abnormal, replace thermistor.
14	Heat exchanger outlet thermistor 1 error		1. Connector contact is faulty. 2. Heat exchanger outlet thermistor TH _{H01} is faulty.	1. Check if the connector of heat exchanger outlet thermistor TH _{H01} loosens or comes off. 2. Check the resistance of heat exchanger thermistor TH _{H01} . If it's abnormal, replace thermistor.
15	Heat exchanger outlet thermistor 2 error		1. Connector contact is faulty. 2. Heat exchanger outlet thermistor TH _{H02} is faulty.	1. Check if the connector of heat exchanger outlet thermistor TH _{H02} loosens or comes off. 2. Check the resistance of heat exchanger outlet thermistor TH _{H02} . If it's abnormal, replace thermistor.
16	Heat exchanger outlet thermistor 3 error		1. Connector contact is faulty. 2. Heat exchanger outlet thermistor TH _{H03} is faulty.	1. Check if the connector of heat exchanger outlet thermistor TH _{H03} loosens or comes off. 2. Check the resistance of heat exchanger outlet thermistor TH _{H03} . If it's abnormal, replace thermistor.
17	Suction thermistor error		1. Connector contact is faulty. 2. Suction temperature thermistor TH _S is faulty.	1. Check if the connector of suction temperature thermistor TH _S loosens or comes off. 2. Check the resistance of suction temperature thermistor TH _S . If it's abnormal, replace thermistor.

ERROR CODE	ERROR	CONTENTS	ERROR CAUSE	COUNTERMEASURE
19	Discharge pressure sensor error	<p>1. Error occurrence condition</p> <p>1) Voltage output from output remains under 0.8V for 3 minutes or longer. However, detection isn't performed for 3 minutes after power is applied to outdoor unit.</p> <p>2) Output sensor detection value is 3.46MPa or higher.</p> <p>2. Relevant operation</p> <p>1) All compressors are stopped.</p> <p>2) Error is displayed on LED of outdoor unit and output to communication bus line.</p> <p>3. Clearance</p> <p>Output voltage from pressure sensor returns within 1- 5V.</p>	Discharge pressure sensor P _H is faulty.	Replace discharge pressure sensor P _H .
1A	Liquid pressure sensor error		Liquid line pressure sensor P _M is faulty.	Replace liquid line pressure sensor P _M .

ERROR CODE	ERROR	CONTENTS	ERROR CAUSE	COUNTERMEASURE
1F	Transmission error	<p>1. Error occurrence condition Communication from each indoor units are cut off for a certain time.</p> <p>2. Relevant operation</p> <p>1) If transmission error occurs after 90 seconds since Outdoor unit circuit board error 1 occurs, all compressors are stopped and error is displayed on LED of outdoor unit.</p> <p>2) If communication from all indoor units are cuts of for a certain time, all compressors are stopped and error is displayed on LED of outdoor unit.</p> <p>3) Except a forementioned operations, only indoor units that completes the communications are operated. Error is displayed on LED of outdoor unit.</p> <p>3. Clearance</p> <p>1) Communication with indoor units is recovered.</p> <p>2) Main power is reset.</p>	1. Effect of extraneous noise	<p>1. When power is turned off, and turned on again:</p> <p>(1) If error doesn't occur, printed circuit board is normal. Then, remove noise sources near outdoor unit.</p> <p>(2) If error occurs again, remove noise sources and take measures with the following countermeasure No.2 to 5.</p>
			2. Communication line is not connected, contact is faulty, or disconnection.	2. Check if communication line is connected to all indoor units. Check if communication line is disconnected.
			3. Indoor unit power is OFF	3. Check indoor units power supply.
			4. Insertion fault for communication printed circuit board of indoor unit or outdoor unit.	4. Check the insertion of indoor unit communication PC board and outdoor unit communication PC board.
			5. PC board is faulty.	<p>5. 1) If transmission error occurs after Parallel communication error replace PC boards with following procedures and check the operation.</p> <p>(1) Replace outdoor unit communication printed circuit board.</p> <p>(2) Replace outdoor unit control printed circuit board.</p> <p>2) when some indoor units in same refrigerant system are operated, replace printed circuit boards with following procedures and make sure the operation.</p> <p>(1) Replace communication printed circuit board of indoor unit that occurs transmission error</p> <p>(2) Replace control printed circuit board of indoor unit that occurs transmission error.</p> <p>3) When an error occurs on all indoor units of the same refrigerant system and compressor does not operate, replace PC boards with following procedures and make sure the operation.</p> <p>(1) Replace outdoor unit communication PC board.</p> <p>(2) Replace outdoor unit control PC board.</p> <p>(3) Replace indoor unit communication PC board.</p> <p>(4) Replace indoor unit control PC board.</p>

ERROR CODE	ERROR	CONTENTS	ERROR CAUSE	COUNTERMEASURE
21	Discharge temperature 1 error	<p>1. Error occurrence condition Discharge temperature 1 rises to 130°C or higher for 40 minutes and compressor 1 is stopped twice or more.</p> <p>2. Relevant operation Error is displayed on LED of outdoor unit and output to communication bus line.</p> <p>3. Clearance When all the following conditions are satisfied:</p> <p>1) Discharge temperature protector 1 reset.</p> <p>2) Discharge temperature protector is not operated for 40 minutes or longer.</p>	<p>1. Gas leak or lack of refrigerant.</p> <p>2. Outdoor fan motor is faulty.</p> <p>3. Discharge temperature sensor TH_{D1} is faulty.</p> <p>4. Electronic expansion valve operation is faulty.</p> <p>5. Solenoid valve operation is faulty.</p>	<p>1. Check the gas leak and additional refrigerant amount, and recharge suitable refrigerant.</p> <p>2. Check outdoor fan motor operation. Remove the obstruction in wind path. If fan motor is faulty, replace motor.</p> <p>3. Check if the wiring of discharge temperature sensor TH_{D1} loosens or comes off and check the resistance TH_{D1}. If it's abnormal, replace sensor.</p> <p>4. Check operation and coil resistance of following electronic expansion valve. If it's abnormal, replace electronic expansion valve. Coil resistance measurement points. Red-white, red-orange, brown-yellow, brown-blue.</p> <p>(1) Outdoor unit electronic expansion valve EEV1 and EEV2 Coil resistance: 192 +/-19 ohms.</p> <p>(2) Indoor units electronic expansion valve EEV Coil resistance: 150 +/-50 ohms.</p> <p>5. Check operation of following solenoid valves. If operation is faulty, replace solenoid valve.</p> <p>Cooling operation.</p> <p>(1) Outdoor unit solenoid valve SV1.</p> <p>(2) RB unit solenoid valves SVB and SVS.</p> <p>Heating operation.</p> <p>(3) Outdoor units solenoid valves SV1, SV7, and SV8.</p> <p>(4) RB unit solenoid valve SVD. Heat recovery operation (1), (2), (3), (4).</p>

ERROR CODE	ERROR	CONTENTS	ERROR CAUSE	COUNTERMEASURE
22	Discharge temperature 2 error	<p>1. Error occurrence condition Discharge temperature 2 rises to 130 °C or higher for 40 minutes and compressor 2 is stopped twice or more.</p> <p>2. Relevant operation Error is displayed on LED of outdoor unit and output to communication bus line.</p> <p>3. Clearance When all the following conditions are satisfied:</p> <p>1) Discharge temperature protector 2 is reset.</p> <p>2) Discharge temperature protector is not operated for 40 minutes or longer.</p>	<p>1. Gas leak or lack of refrigerant.</p> <p>2. Outdoor fan motor is faulty.</p> <p>3. Discharge temperature sensor TH_{D2} is faulty.</p> <p>4. Electronic expansion valve operation is faulty.</p> <p>5. Solenoid valve operation is faulty.</p>	<p>1. Check the gas leak and check additional refrigerant amount and recharge suitable refrigerant.</p> <p>2. Check outdoor fan motor operation. Remove the obstruction in wind path. If fan motor is faulty, replace motor.</p> <p>3. Check if the wiring of discharge temperature sensor TH_{D2} loosens or comes off and check the resistance of TH_{D2}. If it's abnormal, replace sensor.</p> <p>4. Check operation and coil resistance of following electronic expansion valve. If it's abnormal, replace electronic expansion valve. Coil resistance measurement points. Red-white, red-orange, brown-yellow, brown-blue.</p> <p>(1) Outdoor unit electronic expansion valve EEV1 and EEV2 Coil resistance: 192 +/-19 ohms.</p> <p>(2) Indoor units electronic expansion valve EEV Coil resistance: 150 +/-50 ohms.</p> <p>5. Check operation of following solenoid valves. If operation is faulty, replace solenoid valve.</p> <p>Cooling operation</p> <p>(1) Outdoor unit solenoid valve SV1.</p> <p>(2) RB unit solenoid valves SVs</p> <p>Heating operation</p> <p>(3) Outdoor units solenoid valves SV1, SV7, and SV8.</p> <p>(4) RB unit solenoid valve SVD Heat recovery operation (1), (2), (3), (4)</p>

ERROR CODE	ERROR	CONTENTS	ERROR CAUSE	COUNTERMEASURE
23	Discharge temperature 3 error	<p>1. Error occurrence condition Discharge temperature 3 rises 130 °C or greater for 40 minutes and compressor 3 is stopped twice or more.</p> <p>2. Relevant operation Error is displayed on LED of outdoor unit and output to communication bus line.</p> <p>3. Clearance When all the following conditions are satisfied:</p> <p>1) Discharge temperature protector 3 is reset.</p> <p>2) Discharge temperature protector is not operated for 40 minutes or longer.</p>	<p>1. Gas leak or lack of refrigerant.</p> <p>2. Outdoor fan motor is faulty.</p> <p>3. Discharge temperature sensor TH_{D3} is faulty.</p> <p>4. Electronic expansion valve operation is faulty.</p> <p>5. Solenoid valve operation is faulty.</p>	<p>1. Check the gas leak and check additional refrigerant amount and recharge suitable refrigerant.</p> <p>2. Check outdoor fan motor operation. Remove the obstruction in wind path. If fan motor is faulty, replace motor.</p> <p>3. Check if the wiring of discharge temperature sensor TH_{D3} loosens or comes off and check the resistance of TH_{D3}. If it's abnormal, replace sensor.</p> <p>4. Check operation and coil resistance of following electronic expansion valve. If it's abnormal, replace electronic expansion valve. Coil resistance measurement points. Red-white, red-orange, brown-yellow, brown-blue.</p> <p>(1) Outdoor unit electronic expansion valve EEV1 and EEV2 Coil resistance: 192 +/-19 ohms.</p> <p>(2) Indoor units electronic expansion valve EEV Coil resistance: 150 +/-50 ohms.</p> <p>5. Check operation of following solenoid valves. If operation faulty, replace solenoid valve.</p> <p>Cooling operation</p> <p>(1) Outdoor unit solenoid valve SV1</p> <p>(2) RB unit solenoid valves SVs</p> <p>Heating operation</p> <p>(3) Outdoor units solenoid valves SV1, SV7, and SV8</p> <p>(4) RB unit solenoid valve SV_D</p> <p>Heat recovery operation (1), (2), (3), (4)</p>

ERROR CODE	ERROR	CONTENTS	ERROR CAUSE	COUNTERMEASURE
24	High pressure error	<p>1. Error occurrence condition When any of following conditions is satisfied:</p> <p>1) Compressor is stopped twice or more due to high pressure protection within 40 minutes.</p> <p>2) After 3 minutes have passed since compressor is stopped due to high pressure protection and condition of compressor restarting is satisfied, high pressure SW is operated.</p> <p>2. Relevant operation Error is displayed on LED of outdoor unit and output to communication bus line.</p> <p>3. Clearance When all of following conditions satisfied:</p> <p>1) After 3 minutes have passed since compressor is stopped due to high pressure protection and condition of compressor restarting is satisfied, high pressure SW is reset.</p> <p>2) High pressure protection is not operated for 40 minutes or longer.</p> <p>*High pressure SW setting value 3MPa OFF , 2.4MPa ON</p>	<p>1. Ball valve is not opened completely.</p> <p>2. Outdoor unit short cycle</p> <p>3. Outdoor heat exchanger is dirty or clogged with foreign matter.</p> <p>4. Outdoor fan motor is faulty.</p> <p>5. Pressure SW is faulty.</p> <p>6. Indoor unit short cycle</p> <p>7. Filter is clogged.</p> <p>8. Indoor fan motor is faulty.</p> <p>9. Electronic expansion valve operation is faulty.</p> <p>10. Solenoid valve operation is faulty.</p> <p>11. Overload</p>	<p>1. Open ball valve fully.</p> <p>2. Check required installation dimensions.</p> <p>3. Clean heat exchanger or remove foreign matter.</p> <p>4. Check outdoor fan motor operation. Remove the obstruction in wind path. If fan motor faulty, replace motor.</p> <p>5. Check pressure using pressure gauge. If pressure SW is faulty, replace SW.</p> <p>6. Remove obstruction.</p> <p>7. Clean filter.</p> <p>8. Check indoor fan motor operation. If fan motor is faulty, replace motor.</p> <p>9. Check operation and coil resistance of following electronic expansion valve. If it's faulty, replace electronic expansion valve. Coil resistance measurement points Red-white, red-orange, brown-yellow, brown-blue (1) Outdoor unit electronic expansion valve EEV1 and EEV2 Coil resistance: 192 +/-19 ohms. (2) Indoor units electronic expansion valve EEV Coil resistance: 150 +/-15 ohms.</p> <p>10. Check operation of following solenoid valves. If operation faulty, replace solenoid valve. Cooling operation (1) Outdoor unit solenoid valve SVs (2) RB unit solenoid valve SVs Heating operation (3) Outdoor units solenoid valves SV2, SV7, and SV8 (4) RB unit solenoid valve SV_D Heat recovery operation (1), (2), (3), (4)</p> <p>11. Clear the cause of overload (e.g. Caused by indoor unit or outdoor unit installation)</p>

ERROR CODE	ERROR	CONTENTS	ERROR CAUSE	COUNTERMEASURE
27	Oil recovery error	<p>1. Error occurrence condition Oil is judged under oil sensor L level. Oil recovery operation is performed consecutively 3 times or more.</p> <p>2. Relevant operation Error is displayed on LED of outdoor unit.</p> <p>3. Clearance Oil rises over oil sensor L level.</p>	<p>1. Oil recovery solenoid valve is faulty.</p> <p>2. Connector connection is faulty.</p>	<p>1. Check operation of following solenoid valves. If operation is faulty, replace solenoid valve. Compressor 1 solenoid valve SV3. Compressor 2 solenoid valve SV4. Compressor 3 solenoid valve SV5. Central oil return solenoid valve SV6.</p> <p>2. Check if the wiring or connector of solenoid valves loosen or come off.</p>

ERROR CODE	ERROR	CONTENTS	ERROR CAUSE	COUNTERMEASURE
28	Pump down error	1. Error occurrence condition Six minutes have elapsed since pump down is performed, or discharge pressure sensor P _H is 3MPa or higher. 2. Relevant operation 1) All compressors and outdoor fans are stopped. 2) Error is displayed on LED of outdoor unit and output to communication bus line. 3. Clearance Pump down DIP SW1-3 is switched from ON to OFF.	Pump down SW remains ON.	Switch pump down DIP SW1-3 in control printed circuit board of outdoor unit from ON to OFF.
			Outdoor unit fan motors are faulty.	Check outdoor unit fan motors operation. Remove the obstruction in wind path. If the fan motors are faulty, replace the motors.
—	Node setting error	1. Error occurrence condition Communication printed circuit board of outdoor unit isn't initialized correctly. 2. Relevant operation Error is displayed on LED of outdoor unit. 3. Clearance Communication printed circuit board of outdoor unit is initialized correctly.	1. Effect of extraneous noise	1. When power turned off, then turned back on: 1) If error doesn't occur, PC board is normal. Then, remove noise sources near outdoor unit. 2) If error occurs again, remove noise sources and take measure with the following countermeasure No.2.
			2. Printed circuit board is faulty.	2. Replace printed circuit boards with following procedure, and check the operation. (1) Replace Outdoor unit communication PC board (2) Replace Outdoor unit control PC board
—	Parallel communication error	1. Error occurrence condition Communication between control printed circuit board and communication printed circuit board of outdoor unit isn't performed correctly. 2. Relevant operation 1) Current operation is continued. Error is displayed on LED of outdoor unit. 2) If error is kept for 90 seconds since error occurs, new communication error (1F) occurs. 3. Clearance The communication between control printed circuit board and communication printed circuit board of outdoor unit is performed correctly.	1. Effect of extraneous noise	1. When power is turned off, and turned on again: 1) If error doesn't occur, printed circuit board is normal. Then, remove noise sources near outdoor unit. 2) If error occurs again, remove noise sources and take measure with the following countermeasure No.2.
			2. Outdoor unit communication PC board insertion is faulty.	2. Check the insertion of outdoor unit communication printed circuit board.
			3. Printed circuit board is faulty.	3. Replace printed circuit boards with the following procedure, and check the operation. (1) Replace outdoor unit communication printed circuit board (2) Replace outdoor unit control printed circuit board
—	Indoor unit error	Error occurs on indoor unit in same refrigerant system.	Indoor unit is faulty.	See indoor unit troubleshooting.

■CENTRAL REMOTE CONTROLLER TROUBLESHOOTING

ERROR CODE	ERROR	CONTENTS	CAUSE	COUNTERMEASURE
00	No errors			
02	Printed circuit board error (Control panel)	1. Error occurrence condition Error occurs at control panel printed circuit board and central remote controller cannot be operated.	1. Effect of extraneous noise.	1. After ACL key is pressed, or power is turned on again: 1) If error doesn't occur, printed circuit board is normal. Then, remove noise sources near operation panel. 2) If error occurs again, remove noise sources and take measure with the following countermeasure No.2.
		2. Relevant operation Error display.Only error code display is operated. Other operations are ineffective. 3. Clearance □ □ Error is cleared and central remote controller bcomes operable again.	2. Conrol panel printed circuit board is faulty.	2. Replace operation panel printed circuit board.
03	PC board error (Transmission adaptor)	1. Error occurrence condition Error occurs at transmission adaptor control printed circuit board and central remote controller cannot be operated.	1. Effect of extraneous noise	1. After reset key on transmission adaptor control printed circuit board is pressed, or power is turned on again: 1) If error doesn't occur,printed circuit board is normal. Then, remove noise sources near transmission adaptor. 2) If error occurs again, remove noise sources and take measure with the following countermeasure No.2.
		2. Relevant operation Error display.Only error code display operation can be paformed.Other operations are ineffective. 3. Clearance □ □ Error is cleared and central controller bcomes operable again.	2. Transmission adaptor conrol printed circuit board is faulty.	2. Replace transmission adaptor control printed circuit board.
04	Memory error	1. Error occurrence condition Control panel momory is failed, or model infomation and remote controller group registration, which are stored in memory is failed	1. Effect of extraneouse noise	1. Initialize the setting again, after initial setting. 1) If error doesn't occur, printed circuit board is normal. Then, remove noise sources near operation panel. 2) If error occurs again, remove noise sources and take measurre with the following countermeasure NO.2.
		2. Relevant operation 1) Error occurs in normal state. Error and error code are displayed . Only pressing key SW42 on control panel printed circuit boad is effective. Other operations are ineffective. 2) When error occurs in initialize menu mode. Error and error code display. Only pressing SET key is effective. Other operations are ineffective.	2. Control panel PC board is faulty.	2. Replace control panel printed circuit board. 3. Clearances 1) If error occurs in normal condition, Key SW42 on control panel printed circuit board is pressed and the memory is cleared. 2) If error occurs on the initial setting menu mode. Set key is pressed and the memory is cleared.

ERROR CODE	ERROR	CONTENTS	CAUSE	COUNTERMEASURE
05	Node setting error	<p>1. Error occurrence condition Control panel printed circuit board isn't initialized normally.</p> <p>2. Relevant operation Error display. Only error display operation can be performed. Other operations are ineffective.</p> <p>3. Clearance Operation panel printed circuit board initialization operation is performed normally.</p>	<p>1. Effect of extraneous noise</p> <p>2. Printed circuit board is faulty.</p>	<p>1. After ACL key is pressed or power is turned on again :</p> <p>1) If error doesn't occur, printed circuit board is normal. Then, remove noise sources near operation panel.</p> <p>2) If error occurs again, remove noise sources and take measure with the following countermeasure No.2.</p> <p>2. Replace printed circuit boards with following procedure and confirm the operation.</p> <p>① Replace Transmission adapter control printed circuit board.</p> <p>② Replace Transmission adapter communication printed circuit board.</p> <p>③ Operation panel printed circuit board.</p>
06	Parallel communication error	<p>1. Error occurrence condition Communication between transmission adapter board control printed circuit board and transmission adapter communication printed circuit board is not performed normally.</p> <p>2. Relevant operation</p> <p>1) Error indication. Central Remote operation is available.</p> <p>2) If error is kept to detect for a while after error occurs, transmission error (1F) is output.</p> <p>3. Clearance The communication between the control printed circuit board and communication printed circuit board of transmission adaptor is performed correctly.</p>	<p>1. Effect of extraneous noise</p> <p>2. Transmission adapter communication printed circuit board insertion is faulty.</p> <p>3. Printed circuit board is faulty.</p>	<p>1. After RESET key on control printed circuit board of transmission adapter is pressed, or power is turned on again :</p> <p>1) If error doesn't occur, printed circuit board is normal. Then, remove noise sources near transmission adaptor.</p> <p>2) If error occurs again, remove noise sources and take measure with the following countermeasure No.2,3.</p> <p>2. Check insertion for the communication printed circuit board of transmission adaptor.</p> <p>3. Replace printed circuit boards with following procedure and confirm the operation.</p> <p>① Replace Transmission adapter communication board.</p> <p>② Replace Transmission adapter control board.</p>

ERROR CODE	ERROR	ERROR CONTENTS	CAUSE	COUNTERMEASURE
1C	Connection error	<p>1. Error occurrence condition Communication between transmission adapter and control panel is not performed correctly.</p> <p>2. Relevant operation Error display. Only error code display operation can be performed. Other operations are ineffective.</p> <p>3. Clearance The communication between transmission adapter and operation panel is performed correctly.</p>	<p>1. Effect of extraneous noise</p> <hr/> <p>2. Communication line between transmission adapter and control panel connection is faulty or disconnecting.</p> <hr/> <p>3. Communication parameter setting error.</p> <hr/> <p>4. Printed circuit board is faulty.</p>	<p>1-1. Check error continuity.</p> <p>1) If error is cleared automatically, printed circuit board is normal. Then, remove noise sources near central remote controller.</p> <p>2) If error isn't cleared automatically, check following.</p> <p>1-2. After ACL key is pressed, RESET key on control board of transmission adaptor is pressed, or power is turned on again :</p> <p>1) If error doesn't occur, printed circuit board is normal. Then, remove noise sources near central remote controller.</p> <p>2) If error occurs again, remove noise sources and take measure with the following countermeasure No.2,3,4.</p> <hr/> <p>2. Check if communication line between transmission adapter and control panel is disconnected or the other problem for connection occurs.</p> <hr/> <p>3. Check setting of DIP-SW1-1~7 on control panel and DIP-SW2-1~4 and DIP-SW3-1~3 on transmission adapter printed circuit board.</p> <hr/> <p>4. Replace printed circuit boards with following procedure and confirm the operation.</p> <p>① Replace Transmission adaptor control board.</p> <p>② Replace Control panel printed circuit board.</p>

ERROR CODE	ERROR	ERROR CONTENTS	CAUSE	COUNTERMEASURE
1D	Initial setting error	<p>1. Error occurrence condition Initialization is not performed normally. When recognized as only indoor or outdoor unit in the same refrigerant system, or when not recognizing In / Out at all.</p> <p>2. Relevant operation Error display. Central remote controller operation can be performed.</p> <p>3. Clearance Initialization is performed again from key operation.</p>	<p>1. Effect of extraneous noise</p> <p>2. Other remote controller (Standard wired remote controller, wireless remote controller, Central remote controller) is operated.</p> <p>3. Printed circuit board is faulty.</p>	<p>1. Initialize the setting again. 1) If error doesn't occur, printed circuit board is normal. Then, remove noise sources near control panel. If error occurs again, remove noise sources and take measure with the following countermeasure No.2,3.</p> <p>2. Stop operation of other remote controller, and initialize again.</p> <p>3. Check the power supply, wiring, address set-up of Indoor / Outdoor unit. ① Replace Transmission adaptor communication printed circuit board. ② Replace Transmission adaptor control printed circuit board ③ Replace Control panel printed circuit board</p>
1E	Manual storing 2 error	<p>1. Error occurrence condition Manual store 2 is not performed normally.</p> <p>2. Relevant operation Error display. Central remote controller operation can be performed.</p> <p>3. Clearance Storing (automatic allocation, manual storing 1, manual storing 2) is performed from key operation, or initial setting menu mode is cancelled.</p>	<p>1. Effect of extraneous noise</p> <p>2. Printed circuit board is faulty.</p>	<p>1. Perform allocation again. After manual storing 2 setting: 1) If error doesn't occur, printed circuit board is normal. Then, remove noise sources near control panel. If error occurs again, remove noise sources and take measure with the following countermeasure No.2.</p> <p>2. Replace printed circuit boards with following procedures, and confirm the operation. ① Replace Transmission adaptor commutation board. ② Replace Transmission adaptor control board. ③ Replace Control panel printed circuit board.</p>
1F	Transmission error	<p>1. Error occurrence condition Communication between indoor unit and central remote controller is cut off for a certain time.</p> <p>2. Relevant operation 1) Error Indication. Central Remote can be operated. 2) If parallel communication error occurs and communication error occurs after a certain time, error is displayed. Central remote control can be operated.</p>	<p>1. Effect of extraneous noise</p> <p>2. Communication line is not connected, connection fault, or disconnection.</p> <p>3. Indoor unit power off.</p>	<p>1-1. After indoor unit power is turned on again: 1) If error doesn't occur, printed circuit board is normal. Then, remove noise sources near indoor unit. If error occurs again, remove noise sources and take measure with the following countermeasure 1-2.</p> <p>1-2. After ACL key is pressed, or power is turned on again: 1) If error doesn't occur, printed circuit board is normal. Then, remove noise sources near control panel. If error occurs again, remove noise sources and take measure with the following countermeasure No.2-6.</p> <p>2. Check if communication line is wired to each indoor unit.</p> <p>3. Check power supply for indoor unit.</p>

ERROR CODE	ERROR	CONTENTS	ERROR CAUSE	COUNTERMEASURE
1F	Transmission error	3. Clearance For 2-1), the communication with indoor unit is restored. For 2-2), the communication between control printed circuit board and communication printed circuit board of transmission adaptor is performed.	4. Transmission adapter communication printed circuit board or indoor unit communication printed circuit board insertion is faulty. 5. Initialing setting after indoor unit address is changed, is forgotten. 6. Printed circuit board faulty.	4. Check insertion of the communication printed circuit board of transmission adaptor and the communication printed circuit board of indoor unit. 5. Perform initialization. ----- 6. 1) If communication error occurs after parallel communication error occurs, replace printed circuit boards with the following procedure, and make sure the operation. ① Replace Transmission adapter communication printed circuit board. ② Replace Transmission adapter control printed circuit board. 2) For other cases, replace printed circuit boards with following procedure and make sure the operation ① Replace Indoor unit communication printed circuit board. ② Replace Indoor unit control printed circuit board.
21	Software error (OUTPUT)	1. Error occurrence condition If CPU of central remote controller is initialized by momentary power interruption during the operation setting or changing, the setting is reset. 2. Relevant operation Error display. Only error code display can be operated. Other operations are ineffective.	1. Effect of extraneous noise ----- 2. The power supply is shut down or power supply voltage is abnormal. ----- 3. Printed circuit board is faulty.	1-1 Check continuity error. 1) If error is cleared automatically, printed circuit board is normal. Then, remove noise sources near central remote controller. 2) If error isn't cleared automatically, check following. 1-2 After ACL key is pressed, or power is turned on again: 1) If error doesn't occur, printed circuit board is normal. Then, remove noise sources near control panel. 2) If error occurs again, remove noise sources and take measure with the following countermeasure No.2,3. ----- 2. Check power supply voltage and operate after turning on power. ----- 3. Replace printed circuit boards with following procedures and check the operation. ① Replace Transmission adapter control printed circuit board. ② Replace Operation panel printed circuit board.
22	Software error (INPUT)	1. Error occurrence condition Operation condition of indoor units, which is memorized in transmission adapter is abnormal. 2. Relevant operation Error display. Central remote controller can be operated. 3. Clearance When contents of memory, which is memorized in transmission adapter is normal.	1. Effect of extraneous noise ----- 2. Transmission adapter control printed circuit board is faulty.	1-1 Check error continuity. 1) If error is cleared automatically, printed circuit board is normal. Then, remove noise sources near central remote controller. 2) If error isn't cleared automatically, check following. 1-2 After RESET key on control printed circuit board of transmission adapter is pressed, or power is turned on again: 1) If error doesn't occur, printed circuit board is normal. Then, remove noise sources near operation panel. 2) If error occurs again, remove noise sources and take measure with the following countermeasure No.2. ----- 2. Replace transmission adapter control printed circuit board.

■ NETWORK CONVERTOR (UTR-YSSA) TROUBLESHOOTING

ERROR CODE	ERROR	CONTENTS	CAUSE	COUNTERMEASURE
–	No errors			
– –	Initial setting			
05	Circuit board error 1	1. Error occurrence condition The signal synchronization between the network devices is not normally performed. 2. Relevant operation Error code is displayed. All control items are not available. 3. Clearance □ □ Error is cleared when the signal synchronization between the network devices is normally performed.	1. Effect of extraneous noise.	1. After the SW104 button of network convertor PCB is pressed for more than five seconds, or the power of network convertor is reset. 1) If error doesn't occur, printed circuit board is normal. Please remove noise sources near network convertor. 2) If error occurs again, remove noise sources and take measure with the following countermeasure.
			2. Network convertor printed circuit board is faulty.	2. Replace the network convertor printed circuit board.
06	Circuit board error 2	1. Error occurrence condition Error occurs when the memorized information in EEPROM is faulty or when the initial setting of network convertor is not performed correctly. 2. Relevant operation Error code is displayed. Other control methods are still possible. 3. Clearance □ □ Error is cleared when the network convertor becomes operable again.	1. Effect of extraneous noise.	1. After the SW104 button of network convertor PCB is pressed for more than five seconds, or the power of network convertor is reset. 1) If error doesn't occur, printed circuit board is normal. Please remove noise sources near network convertor. 2) If error occurs again, remove noise sources and take measure with the following countermeasure.
			2. Network convertor printed circuit board is faulty.	2. Replace the network convertor printed circuit board.
18	Transmission error with wired RC	1. Error occurrence condition Transmission between standard wired remote controller and network convertor is not performed normally. 2. Relevant operation 1) Error code are displayed. Control from and display on the standard wired remote controller cannot be performed. Other control methods are still possible. 3. Clearance □ □ Transmission between standard wired remote controller and network convertor is performed normally.	1. Effect of extraneous noise.	1. After the SW104 button of network convertor PCB is pressed for more than five seconds, or the power of network convertor is reset. 1) If error doesn't occur, printed circuit board is normal. Please remove noise sources near network convertor. 2) If error occurs again, remove noise sources and take measure with the following countermeasure.
			2. The remote controller line between network convertor and standard remote controller is not connected or the connection is faulty.	2. Check the remote controller line to find whether it has been disconnected, connected faultily and has a wrong wiring or not.
			3. The setting of DIP-SW 107[2] of network convertor (wired RC validity / invalidity setting) is faulty.	3. Check the setting of DIP-SW 107[2] of network convertor.
			4. The selection of standard remote controller is faulty.	4. Check whether the standard remote controller of VRF type is connected.
			5. The setting of DIP-SW1-1,1-4 of standard remote controller (Number of connected remote controllers) is faulty.	5. Check the setting of DIP-SW 1-1 and DIP-SW 1-4 of standard remote controllers.
			6. Standard wired remote controller printed circuit board or network convertor printed circuit board is faulty.	6. Replace standard wired remote controller printed circuit board or network convertor printed circuit board

ERROR CODE	ERROR	CONTENTS	CAUSE	COUNTERMEASURE
1C	Transmission error with indoor unit	<p>1. Error occurrence condition Transmission between indoor units and network convertor is not performed normally.</p> <p>2. Relevant operation 1) Error code are displayed. All control items are not available.</p> <p>3. Clearance □ □ Transmission between indoor units and network convertor become normal again.</p>	1. Effect of extraneous noise.	<p>1-1 After the SW104 button of network convertor PCB is pressed for more than five seconds, or the power of network convertor is reset.</p> <p>1) If error dosen't occur, printed circuit board is normal. Please remove noise sources near network convertor.</p> <p>2) If error occurs again, remove noise sources and take measure with the following countermeasure.</p> <p>1-2 After the power of indoor units is reset:</p> <p>1) If error dosen't occur, printed circuit board is normal. Please remove noise sources near indoor units.</p> <p>2) If error occurs again, remove noise sources and take measure with the following countermeasure.</p>
			2. The remote controller line between network convertor and indoor units is not connected or connection is faulty.	2. Check the remote controller line to find whether it has been disconnected, connected faultily, wrong wiring or not.
			3. The power of indoor units is OFF.	3. Check the power supply of indoor units.
			4. The indoor unit address setting is faulty.	4. Check the indoor unit address setting.
			5. The setting of DIP-SW of network convertor is faulty.	<p>5. Check the setting of DIP-SW103[1-4] of network convertor to conform the matching between indoor unit type and RC type.</p> <p>Check the setting of DIP-SW103[5-8] of network convertor to conform the number of the connected indoor units.</p>
			6. Indoor unit printed circuit board or network convertor printed circuit board is faulty.	6. Replace indoor unit circuit board or network convertor printed circuit board.
1F	Transmission error with VRF system	<p>1. Error occurrence condition Transmission between VRF system and network convertor is not performed normally. Undefined signal is accepted from VRF system.</p> <p>2. Relevant operation Error code is displayed. Control from and display on VRF system cannot be performed. Other control methods are still possible.</p>	1. Effect of extraneous noise.	<p>1-1 Check the continuity of error.</p> <p>1) If error is cleared automatically, printed circuit board is normal. Please remove noise sources near network convertor.</p> <p>2) If error isn't cleared automatically, check following.</p> <p>1-2 After the SW104 button of network convertor PCB is pressed for more than five seconds, or the power of network convertor is reset.</p> <p>1) If error doesn't occur, printed circuit board is normal. Please remove noise sources near network convertor.</p> <p>2) If error occurs again, remove noise sources and take measure with the following countermeasure.</p>

ERROR CODE	ERROR	CONTENTS	CAUSE	COUNTERMEASURE
1F	Transmission error with VRF system	3. Clearance□ □ Transmission between VRF system and network convertor is performed normally.	1. Effect of extraneous noise.	1-3 After the power of VRF system is reset: 1) If error doesn't occur, printed circuit board is normal. Please remove noise sources near VRF system. 2) If error occurs again, remove noise sources and take measure with the following countermeasure.
			2. Network convertor printed circuit board is faulty.	2. Replace the network convertor printed circuit board.
			3. Printed circuit board of device of VRF system is faulty.	3. Replace the printed circuit boards of device of VRF system.
21	Software error	1. Error occurrence condition An incorrect control is performed by microcomputer program. 2. Relevant operation Error code is displayed. All control items are not available. 3. Clearance□ □ Error is cleared when the network convertor return to operate normally after the power of microcomputer is reset.	1. Effect of extraneous noise.	1-1 Check the continuity of error. 1) If error is cleared automatically, printed circuit board is normal. Please remove noise sources near network convertor. 2) If error isn't cleared automatically, check following. 1-2 After the SW104 button of network convertor PCB is pressed for more than five seconds, or the power of network convertor is reset. 1) If error doesn't occur, printed circuit board is normal. Please remove noise sources near network convertor. 2) If error occurs again, remove noise sources and take measure with the following countermeasure.
			2. Network convertor printed circuit board is faulty.	2. Replace the network convertor printed circuit board.
32	Indoor or outdoor unit error	1. Error occurrence condition Error occurs on indoor or outdoor units which are connected with network convertor. 2. Relevant operation Error code is displayed. Other control methods are still possible. 3. Clearance□ □ When the error of indoor or outdoor units which are connected with network convertor is cleared.	1. Indoor unit is faulty.	1. See troubleshooting of relevant indoor unit.
			2. Outdoor units is faulty.	2. See troubleshooting of relevant outdoor unit.

5-5-2 TROUBLE SHOOTING WITH NO ERROR CODE

How to read the tables

1. Select the relevant item of errors from 1 to 5 below, and decide the table to be used.
2. Deduce "Cause" from "LED display" and "Symptoms that can occur other than title".
3. Check if the deduced "Cause" is correct by means of "Check method" and "Remarks".

When there is no error code display at the indoor unit, outdoor unit or central remote controller, but there is one of the following operation errors, check the cause in the following order:

1. Indoor fan does not operate normally.
2. System does not cool or heat.
3. Abnormal sound is heard from indoor unit.
4. Water leaking from indoor unit.
5. Others.

1. Indoor unit fan does not operate normally

LED display			Symptoms that can occur other than title	Cause	Check method (Error state check method)	Remarks
Indoor unit	Outdoor unit	Remote controller				
Body LED	PCB LED 1 to 6	LCD				
No display	Error display (Transmission line error) ※	No display	—	Power is not supplied to indoor unit. Circuit breaker is at OFF position. Power line is faulty.	Check the voltage between power supply terminals 1 and 2 of each indoor units.	Voltage between terminals 1 and 2: 220~240V
<div style="border: 1px solid black; padding: 2px;">※ Become normal after the power is reset.</div>			—	Indoor unit is short circuiting. (The circuit to which voltage is applied when operation is short circuiting (leakage of electricity).)	The breaker falls immediately after turning on the breaker of the indoor units. The resistance between the power terminal block and the metal parts of any indoor units is almost zero.	When short circuit occurred, the resistance between power supply terminals 1 and 2 of indoor unit approaches to zero.
				Indoor unit is short circuiting. (The circuit to which voltage is applied when operation is short circuiting (leakage of electricity).)	When the indoor unit circuit breaker trips during operation, locate the faulty indoor unit by disconnecting the PCBs one by one (disconnect CN1). Then check the individual electric parts to distinguish the parts which cause the leakage of electricity.	If short circuited, there is a electric part whose resistance between two electrodes will indicate a value near zero.
Error display (Remote controller communication system error) ※	Error display (Indoor unit error) ※	Normal display or no display	—	Communication line is faulty between indoor unit and wired remote controller or simple remote controller. Open circuit.	When any of 1-2, 2-3, and 3-1 at the indoor unit terminal board for remote controller are shorted, however, the resistances between red and white or white and black or black and red do not indicate a value near zero.	
<div style="border: 1px solid black; padding: 2px;">※ Become normal after the power is reset.</div>			—	Communication line between indoor units for remote controller group control is faulty. Open circuit.	Check the wiring color and the wiring connection of indoor unit terminal board for remote controller.	The combinations of wiring color and indoor unit terminal board for remote controller are as following: red to 1, white to 2 and black to 3.
				Communication line is faulty between indoor unit and wired remote controller or simple remote controller. Erroneous connection. (polarity incorrect)	When any of 1-2, 2-3, and 3-1 at the indoor unit terminal board for remote controller are shorted, however, the resistances between red and white or white and black or black and red do not indicate a value near zero.	
Normal display	Normal display	Normal display or no display	—	Communication line between indoor units for remote controller group control is faulty. Erroneous connection. (polarity incorrect)	Check the wiring color and the wiring connection of indoor unit terminal board for remote controller.	The combinations of wiring color and indoor unit terminal board for remote controller are as following: red to 1, white to 2 and black to 3.
				The setting of master/slave setting switch (DIP SW 1-4) of the remote controller is not correct.	When indoor unit operated for each remote control group, operation is abnormal.	Do not start to operate when there is no master unit (SW 1-4 set to OFF) in one remote controller group.
				Capacity of the indoor fan capacitor is faulty.	Check the indoor unit Model No. and capacity of the capacitor.	
				Thermo-control	The set temperature is very close to the room temperature and a sent louver operation signal is not accepted by indoor unit.	Indoor fan operates 1-2 minutes for every five minutes during thermo-control.
				Cold air prevention control is in progress (heating operation).	The area (heat exchanger) near outlet of the indoor unit is not warm and up/down louvers are set to a horizontal position.	Wait several minutes, then restart the heating operation.
				Cool/heat switching control is in progress.	At least 3 minutes did not elapse after switching the operation mode from cooling to heating or from heating to cooling.	When the operating state was switched from cool to heat, heat to cool, or stop to heat, it takes 3 minutes to balance the refrigerant pressure in the RB unit.

LED display			Symptom that can occur other than title	Cause	Check method (Error state check method)	Remarks
Indoor unit	Outdoor unit	Remote controller				
Body LED	PCB LED 1 to 6	LCD				
Normal display	Normal display	Filter sign display※	—	The meshes of the filter were clogged up.	Check if the filter is dirty.	When the operating time of fan motor of any indoor unit exceeds 150 hours, the filter cleaning sign appears at the wired remote controller. The operating time of fan motor can be reset by pushing the ZONE/SET button for more than 3 seconds. ※ The filter cleaning sign is informed by flashing of the set temperature display(1 sec. ON, 1 sec. OFF and repeat).
Controlling display (Operation display LED flashes)※	Controlling display (Oil recovery operation)	Normal display	Abnormal sound is heard from indoor unit.	Oil recovery operation control is in progress.	All indoor unit fans stop and the signal sent from remote controller is not accepted by indoor unit.	1st oil recovery operation: 1 hour (operation time) after the power turned on. 2nd oil recovery operation and afterwards: every 6 hours (operation time). ※ Operation LED flashes (3 sec. ON, 1 sec. OFF and repeats).
Error display (Indoor unit fan error)※	Normal display	Error display (Indoor unit fan error)※	—	Indoor fan capacitor is faulty.	Check the resistance value of the capacitor. (If normal, the resistance will show a value of several hundred kilohms.)	Large ceiling type, slim body cassette type and ceiling wall type will inform the error.(Others don't) Warning: 1) For large ceiling model or slim body cassette model, perform check by following procedures: (1)Turn off the power of indoor unit. Wait for several minutes. (2)Disconnect the plug from PCB. (3)Fully discharge the electricity before doing check. (4)Check the resistance of capacitor for large ceiling or slim body cassette. 1-2 of terminal CN3. (5)Check the motor resistance: For large ceiling model, check resistances (4-5, 5-6) of CN4. For slim body cassette model, check resistances (5-6, 5to1,2,4) of CN4. 2) For ceiling wall model, check the voltages of CN3: V ₆₋₄ =340(V), V ₃₋₄ =15(V), V ₂₋₄ =2-8 (V)
				Indoor fan motor is faulty.	Check the fan motor resistance or voltage.	
Error display (Thermistor error)※	Error display (Indoor unit error)	Error display (Thermistor error)※	System does not cool/heat.	Indoor unit thermistor is faulty.	Measure the thermistor resistance and compare it to the ambient temperature.	Refer to section 7-2-1 for the temperature and thermistor resistance relationship. ※ When thermistor shorted or open, error occurs.
Normal display	Normal display or Error display (Discharge temperature error)	Normal display	System does not cool/heat.	Indoor unit short circuit.	Air flow out from an indoor unit is sucked directly into the same indoor unit or into another indoor unit.	
No display or Error display (Cannot be specified.)	Cannot be specified	No display or Error display (Cannot be specified.)	System does not cool/heat. Abnormal sound is heard from indoor unit.	Indoor control PCB is faulty.	Symptom has many branches, depending on the error contents, and there is no effective check method.	If the problem is caused by PCB or connection wire the trouble is often sloved by a change of PCB or connection wire.
Cannot be specified.	No display or Error display (Cannot be specified.)	Cannot be specified.	System does not cool/heat. Abnormal sound is heard from indoor unit.	Outdoor control PCB is faulty.	Symptom has many branches, depending on the error contents, and there is no effective check method.	If the problem is caused by PCB or connection wire the trouble is often sloved by a change of PCB or connection wire.

2. System does not cool or heat

LED display			Symptom that can occur other than title	Cause	Check method (Error state check method)	Remarks
Indoor unit	Outdoor unit	Remote controller				
Body LED	PCB LED 1 to 6	LCD				
Error display (Communication error) ※	No display	Error display (Communication error) ※	—	Power is not supplied to outdoor unit. Circuit breaker is at OFF position. Power line is faulty.	Check the voltage of power supply terminal board of outdoor unit.	Voltages between R-S, S-T, and T-R are 380~415V Voltages between R-N, S-N, and T-N are 220~ 240V.
※ Become normal after the power is reset.				Outdoor unit is short circuiting. (The circuit to which voltage is applied when operation is short circuiting (leakage of electricity).)	The breaker falls immediately after turning on the breaker of the outdoor units. The resistance between the power terminal block and the metal parts of outdoor units is almost zero.	When short circuit occurred, the resistances between power supply terminals (R-S, S-T, T-R, R-N, S-N, T-N) of outdoor unit approach to zero.
				Outdoor unit is short circuiting. (The circuit to which voltage is applied when operation is short circuiting (leakage of electricity).)	The outdoor unit circuit breaker trips during operation. The resistance value of the outdoor unit electric parts and outdoor unit metal part approaches zero.	If short circuited, there is a electric part whose resistance between two electrodes will indicate a value near zero.
Normal display	Normal display	Normal display	—	Indoor unit refrigerant system address (SW 8,9) setting is incorrect.	When the indoor units are operated one by one, there is an indoor unit whose outdoor unit does not operate.	Set the address to the same refrigerant system address of the outdoor unit to which the refrigerant piping is connected.
				Indoor unit address (SW 6) setting is incorrect. (address duplicated)	Operate each indoor unit for 5 minutes or more. The relevant outdoor unit stops and operates unsteadily. (Compressor capacity and heat exchange capacity is incorrect by observing the LED of PCB of outdoor unit.)	Multiple indoor units in one refrigerant system must not be set to the same indoor unit address.
				Installed piping is unsuitable. pipe length is too long. (Actual length exceeds 100m)	Check the position of outdoor and indoor units and estimate the piping length.	When the pipe length is too long, the cooling and heating capacity may be insufficient.
				Installed piping is unsuitable. Gas pipe diameter is incorrect.	Check the indoor unit capacity and pipe diameter.	When the gas pipe diameter is large, cooling and heating capacity will be insufficient.
				Refrigerant leakage.	Check refrigerant leakage using a gas detector. (Refrigerant charged state)	Regarding air tightness test after installation or repair, pressurize the system with nitrogen (2.94MPa) and test for leaks with soapy water and allow the system to stand for 24 hours, and then check that there is no drop in pressure. (Note: When the outdoor temperature changes 5°C, the test pressure changes 0.05MPa.)
				Insufficient gas (light)	During the cooling operation, the air flow temperature does not become low when all the indoor units are operating. During the heating operation, the air flow temperature does not become high when only one indoor unit is operating.	For light gas insufficiency, capacity drops only in a specific operation state. (Note that this symptom resembles faulty caused by a bad opening of indoor unit's electronic expansion valve.)

LED display			Symptom that can occur other than title	Cause	Check method (Error state check method)	Remarks
Indoor unit	Outdoor unit	Remote controller				
Body LED	PCB LED 1 to 6	LCD				
Normal display	Normal display	Normal display	—	Indoor unit electronic expansion valve doesn't work. Fully closed state. (Don't open)	When the relevant indoor unit performs the cooling operation, the compressor operates, but the air flow temperature of the indoor unit is not cool. When the relevant indoor unit performs the heating operation, the compressor operates, but the air flow temperature of the indoor unit is not warm.	(1)Disconnect the plug from PCB and check the coil resistance (red-white, red-orange, brown-blue, brown-yellow):100~200 Ω (2)Turn off the power source of PCB of the indoor unit to initialize the electronic expansion valve for several times. Put a 3-minute interval between each initializations. The electronic expansion valve may return to normal.
			RB unit solenoid valve (SV _D) is faulty.	During heating operation, a voltage (AC 220-240V) is applied to indoor control PCB CN6 [in the cases of wall mounted and ceiling wall type indoor units CN5] (across terminals 2-4), but the gas pipe and airflow of indoor unit does not become warm.	(1)Check the voltage. (2)Disconnect the plug from PCB and check the coil resistance: Coil resistance : 1,200 ~ 1,500 Ω Terminal1(yellow), 2(black) and 4(red).	
			RB unit solenoid valve (SV _s) is faulty.	During cooling operation, a voltage (AC 220-240V) is applied to indoor control PCB CN6 [in the cases of wall mounted and ceiling wall type indoor units CN5] (across terminals 1-4), but the gas pipe and airflow of indoor unit does not become cool.		
			Outdoor unit electronic expansion valves(EEV1, EEV2) doesn't work. Fully closed state (Don't open).	When a voltage(AC220V) is applied to the coil of the heat exchange 4-way valves(4WV2, 4WV3, 4WV4) and to the heat exchanger solenoid valves(SV7, SV8) corresponding to the electronic expansion valves, the outlet pipes of electronic expansion valves don't become cold in heating operation condition.	Turn off the power source of PCB of the outdoor unit to initialize the electronic expansion valves for several times. Put a 3-minute interval between each initializations. The electronic expansion valve may return to normal. Check the oil resistance(red-white, red-oreange, brown-blue, brown-yellow): 170~210 Ω .	
			Outdoor unit electronic expansion valve(EEV1, EEV2) opening is faulty. Open excessively (fully open).	There is no effective check method.	At low outdoor temperatures, cooling may become poor when EEV1 or EEV2 is open excessively. Turn off the power source of PCB of the outdoor unit to initialize the electronic expansion valves for several times. Put a 3-minute interval between each initializations. The electronic expansion valve may return to normal. Coil resistance (red-white, red-orange, brown-blue, brown-yellow): 170~210 Ω	

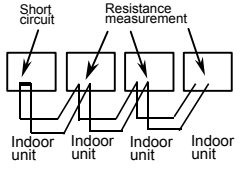
LED display			Symptom that can occur other than title	Cause	Check method (Error state check method)	Remarks
Indoor unit	Outdoor unit	Remote controller				
Body LED	PCB LED 1 to 6	LCD				
Normal display	Normal display	Normal display	Abnormal sound is heard from indoor unit.	Installed piping is not suitable. Liquid piping diameter is incorrect.	Check the capacity of indoor unit and the pipe diameter.	When the diameter is large, a refrigerant rushing sound is generated and when the diameter is small, capacity will be insufficient.
				Outdoor heat exchanger switching 4-way valves (4WV2, 4WV3, 4WV4) or solenoid valves (SV7, SV8) are faulty.	Check the heat exchanger operation capacity at the LED on the outdoor control PCB (Refer to section 5-2). Check the energized state (AC220-240V) of the heat exchanger 4-way valve and solenoid valves. Check the temperature of the pipes connecting these valves.□	When a 4-way valves or solenoid valves are faulty, the high pressure will rise during the cooling operation and the low pressure will fall during the heating operation. Coil resistance : 1200~1500Ω.
			High pressure rises or falls abnormally.	Refrigerant additional charge is unsuitable.	Check the model and model code of indoor units, liquid piping diameter, pipe length and calculation for additional charge.(Refer to section 6-1).	When gas is insufficient, the capacity drops and when gas is excessive, the high pressure rises abnormally.
Error display (Outdoor unit error) ※	Error display (Communication error) ※	Error display (Outdoor unit error) ※	—	Indoor~outdoor unit communication line faulty.	When one of communication terminal board (Transmission) terminals 1-2 of the indoor units is shorted, the resistance between 1 and 2 of communication terminal board (Transmission) of all the indoor units become zero.	
<div style="border: 1px solid black; padding: 2px; width: fit-content;"> ※ Become normal after the power is reset. </div>						
Normal display	Normal display or error display (Compressor error)	Normal display	—	Refrigerant is seriously insufficient.	When the number of operating indoor units was changed, the discharge temperature of the indoor units does not become low or high.	When the gas insufficiency become seriously, the high pressure drops and the discharge temperature increases abnormally.
Error display (Thermistor error)	Error display (Indoor unit error)	Error display (Thermistor error) ※	The fan of the indoor unit does not rotate.	Indoor thermistor is faulty.	Measure the thermistor resistance and compare it to the ambient temperature.	Refer to section 7-2-1 to find the correlation between the temperature and thermistor resistance. ※ When short or open circuit of thermistor occurred.
Normal display	Error display (High pressure error)	Normal display	—	Miswiring between RB unit and indoor unit.	When a relevant indoor unit performs the heating operation, the high pressure becomes high and warm air is not discharged from the indoor unit.	Wiring between RB unit and indoor unit must correspond to the piping connection. (Trouble occurs especially easily with the UTF-Y90A4A.)

LED display			Symptom that can occur other than title	Cause	Check method (Error state check method)	Remarks
Indoor unit	Outdoor unit	Remote controller				
Body LED	PCB LED 1 to 6	LCD				
Error display (Outdoor unit error)	Error display (Thermistor error) ※	Error display (Outdoor unit error)	—	Outdoor thermistor is faulty.	Check by measuring the thermistor resistance and comparing it to the ambient temperature.	Refer to section 7-2-1 to find the correlation between the temperature and thermistor resistance. ※ When short or open circuit of thermistor occurred.
Normal display	Normal display or error display (High pressure error)	Normal display	—	Outdoor fan capacitor is faulty.	Check the capacity (11uF) and resistance of the capacitor.	Resistance between fan motor wires: Blue-white : 60 ohms, white-red : 40 ohms, red-blue : 20 ohms
				Outdoor fan motor is faulty.	Voltage (AC 220-240V) is applied to motor, but motor does not rotate.	
				Outdoor unit electronic expansion valves (EEV1, EEV2) don't work. Fully closed state (don't open) during cooling operation. □	When the electronic expansion valves (EEV1, EEV2) are working correctly, the temperature of pipes which are before and after the electronic expansion valve is clearly different.	When EEV1 and 2 are fully closed during the cooling operation, the high pressure may rise abnormally and the gas may become insufficient and the low pressure may drop. Coil resistance (red-white, red-orange, brown-blue, brown-yellow) : 170~210 Ω Turn off the power source of PCB of the outdoor unit to initialize the electronic expansion valves for several times. Put a 3-minute interval between each initializations. The electronic expansion valve may return to normal.
			Abnormal sound is heard from indoor unit.	Ball valve and 3 way-valve are not fully opened.	Check the positions of spindle (handel) of the 3-way valve and ball valve.	Open the 3-way valve and ball valves fully.
Normal display	Normal display or error display (Discharge temperature error)	Normal display	—	Short-circuit of air circulation of outdoor units occurred.	Air discharged from an outdoor unit is directly sucked into the same outdoor unit or into another outdoor unit.	
				Outdoor unit heat exchanger is blocked with foreign objects.	Not enough space around outdoor unit. The surface of heat exchanger of outdoor unit was covered with dirty or other foreign objects.	Refer to the 'Design and Technical Data' manual for the service space. If there is an obstacle covering the surface of heat exchanger, remove it.

LED display			Symptom that can occur other than title	Cause	Check method (Error state check method)	Remarks
Indoor unit	Outdoor unit	Remote controller				
Body LED	PCB LED 1 to 6	LCD				
Controlling display (Operation display LED flashing) ※1	Controlling display (Defrosting operation)	Normal display ※2	—	Defrosting operation in progress.	Outdoor unit heat exchanger extremely cold. (- 5°C or less)	※1 Operation display LED flashes (3 seconds ON, 1 second OFF) and repeats. ※2 DEFROST message appears on the display of the remote controller.
Error display (Outdoor unit error display)	Error display (Compressor error)	Error display (Outdoor unit error)	—	Compressor is faulty.	Voltage (AC380-415V) is applied to secondary side of magnetic relay, but compressor does not operate. → Compressor lock → Compressor motor burned	When one or two of three compressors damaged, recovery operation will start automatically. Resistance of compressor at 25°C (line-to-line) Comp. 1 : 8.64 Ω (+/- 7%). Comp. 2 : 3.700 Ω (+/- 7%). Comp. 3 : 0.517 Ω (+/- 7%).
				Compressor is faulty. Compressor lock	When the compressor does not operate, measure the line-to-line and line-to-ground resistance of the compressor. (When the compressor is locked, the resistance will show a normal value.)	When this trouble occurs, the oil in the compressor has deteriorated (with black color). Therefore, long-term operation should avoid because it will cause another compressor lock.
				Compressor is faulty. Compressor motor burned	When the compressor does not operate, measure the line-to-line and line-to-ground resistance of the compressor. (When the motor is burned, the line-to-line resistance increases (open circuit) and line-to-ground resistance decreases.)	When this trouble occurs, the oil may not deteriorate. Therefore, operation can be continued, the power line of the damaged compressor must be disconnected.
Error display (Outdoor unit error)	Error display (Reverse phase error)	Error display (Outdoor unit error)	—	Compressor is faulty. Reverse phase	The compressor operates, but the high pressure does not rise.	The compressor wiring is red-R, white-S, and black-T.
Error display (Communication error) ※	Error display (Communication error) ※	Error display (Communication error) ※	—	Outdoor unit communication PCB is faulty.	When power reset for the outdoor or indoor unit is repeated, a communication error is generated.	If the display returns to normal by reset during no communicating period, the communication PCB or communication line may be abnormal.
<div style="border: 1px solid black; padding: 2px; width: fit-content;"> ※ Become normal after the power is reset. </div>						
No display or error display (cannot be specified)	Cannot be specified.	No display or error display (cannot be specified)	The fan of the indoor unit does not rotate. Abnormal sound is heard from indoor unit. □	Indoor unit control PCB is faulty.	The symptom has many branches, depending on the error contents, and there is no effective check method.	When the PCB or the connection wiring is faulty, problem can often be solved by replacing the PCB.
Cannot be specified.	No display or error display (cannot be specified)	Cannot be specified.	The fan of the indoor unit does not rotate. Abnormal sound is heard from indoor unit. □	Outdoor unit control PCB is faulty.	The symptom has many branches, depending on the error contents, and there is no effective check method.	When the PCB or the connection wiring is faulty, problem can often be solved by replacing the PCB.

3. Abnormal sound is heard from the indoor unit.

LED display			Symptom that can occur other than title	Cause	Check method (Error state check method)	Remarks
Indoor unit	Outdoor unit	Remote controller				
Body LED	PCB LED 1 to 6	LCD				
Normal display	Normal display	Normal display	—	Solenoid valves (SV _{B1,2}) of RB unit are faulty.	When heating operation starts, a voltage (AC220-240V) is applied to indoor unit control PCB CN6 [in the cases of wall mounted and ceiling wall type indoor units CN5] (across terminals 3-4), but 3 minutes later a loud refrigerant rushing sound is generated from the RB unit.	(1)Check the voltage. (2)Disconnect the plug from PCB and check the coil resistance: Coil resistance : 1,200 ~ 1,500 Ω. Between terminal 3(white) and 4(red).
				Indoor electronic expansion valve opening is faulty.	—	Coil resistance (red-white, red-orange, brown-blue, brown-yellow) : 100~200 Ω.
			The cooling capacities of indoor units except for the relevant indoor unit are insufficient.	Electronic expansion valve opening of the relevant indoor unit is out of control (open excessively) during cooling operation.	The area (heat exchanger) near the air diffuser is cool even after several minutes have elapsed since the relevant indoor unit was stopped. (the gas pipe of the relevant indoor unit remains cold)	When the electronic expansion valve is open excessively, other indoor units may not operate at full capacity or a loud refrigerant rushing sound may be generated.
			Frost may form on the surface of the heat exchanger of the relevant indoor unit. □	Electronic expansion valve opening of the relevant indoor unit is out of control (open excessively) after stopping cooling operation.		If the electronic expansion valve of the stopping indoor unit remains open, frost may form on the surface of the heat exchanger of the indoor unit. Turn off the power source of PCB of the indoor unit to initialize the electronic expansion valves for several times. Put a 3-minute interval between each initializations. The electronic expansion valve may return to normal.
			The heating capacities of indoor units except for the relevant indoor unit are insufficient.	Electronic expansion valve opening of the relevant indoor unit is out of control (open excessively) during heating operation.	The temperature of air flow as well as inlet pipe of the electronic expansion valve of the relevant indoor unit is higher than those of other indoor units.	Turn off the power source of PCB of the indoor unit to initialize the electronic expansion valves for several times. Put a 3-minute interval between each initializations.
				Electronic expansion valve opening of the relevant indoor unit is out of control (open excessively) when the indoor unit stop heating operation.	The temperature of inlet pipe of the electronic expansion valve do not become low.	The electronic expansion valve may return to normal.
			System does not cool / heat	Outdoor heat exchanger switching 4-way valves (4WV2, 4WV3, 4WV4) or solenoid valves (SV7, SV8) are faulty.	Check the heat exchanger operation capacity at the LED on the outdoor control PCB (Refer to section 5-2). Check the energized state (AC220-240V) of the heat exchanger 4-way valve and solenoid valves. Check the temperature of the pipes connecting these valves. □	When a 4-way valves or solenoid valves are faulty, the high pressure rises during the cooling operation and the low pressure drops during the heating operation. Coil resistance : 1200~1500 Ω
Installed piping is unsuitable. Liquid piping diameter is incorrect.	Check the indoor unit capacity and pipe diameter.	When the diameter is large, a refrigerant rushing sound will be generated and when the diameter is small, capacity will be insufficient.				

LED display			Symptom that can occur other than title	Cause	Check method (Error state check method)	Remarks
Indoor unit	Outdoor unit	Remote controller				
Body LED	PCB LED 1 to 6	LCD				
Normal display	Normal display or error display (High pressure error)	Normal display	System does not cool / heat.	Ball valve and 3 way-valve are not fully opened.	Check the positions of spindle (handel) of the 3-way valve and ball valve.	Open the 3-way valve and ball valves fully.
Controlling display (Operation display LED flashes)※	Controlling display (Oil recovery operation)	Normal display	Indoor unit not operating.	Oil recovery operation control is in progress.	All indoor unit fans stop and the signal sent from remote controller is not accepted by indoor unit.	1st oil recovery operation: 1 hour (operation time) after the power turned on. 2nd oil recovery operation and afterwards: every 6 hours (operation time). ※Operation LED flashes (3 sec. ON, 1 sec. OFF and repeat).
No display or error display (Cannot be specified.)	Cannot be specified.	No display or error display (Cannot be specified.)	The fan of the indoor unit does not rotate. System does not cool / heat.	Indoor control PCB is faulty.	The symptom has many branches, depending on the error contents, and there is no effective check method.	When the PCB or the connection wiring is faulty, problem can often be solved by replacing the PCB.
Cannot be specified.	No display or error display (Cannot be specified.)	Cannot be specified.	The fan of the indoor unit does not rotate. System does not cool / heat.	Outdoor control PCB is faulty.	The symptom has many branches, depending on the error contents, and there is no effective check method.	When the PCB or the connection wiring is faulty, problem can often be solved by replacing the PCB.

4. Water leaks from the indoor unit.

LED display			Symptom that can occur other than title	Cause	Check method (Error state check method)	Remarks
Indoor unit	Outdoor unit	Remote controller				
Body LED	PCB LED 1 to 6	LCD				
Normal display	Normal display	Normal display	—	Drain hose is faulty.	Tilt the drain hose from the indoor unit to the drain outlet.	The same symptom will also appear when the drain hose is clogged.
Error display (Drain error) ※	Error display (Indoor unit error)	Error display (Drain error) ※	—	Drain pump is faulty (Cassette type only)	During cooling operation, drain pump is not effective even though a voltage (DC5V) is applied to the terminal of CN5 (for wall mounted and ceiling wall type: CN4).	※ Generated when the float switch does not return even though 3 minutes have elapsed after the operation signal was sent from the float switch.
				Float switch is faulty.	Remove the float switch and move the float up and down and check the resistance.	When the float is lowered, the circuit is open (high resistance) and when the float is raised, the circuit is closed (low resistance). ※ Occur when the float switch does not return even though 3 minutes have elapsed after the operation signal was sent from the float switch.

5. Others

LED display			Symptom that can occur other than title	Cause	Check method (Error state check method)	Remarks
Indoor unit	Outdoor unit	Remote controller				
Body LED	PCB LED 1 to 6	LCD				
Normal display	Normal display	Normal display		The electronic expansion valve opening of indoor unit is faulty.		When the indoor unit power is reset 5~10 times at a 2~3 minutes interval, the expansion valve may close. Coil resistance (red-white, red-orange, brown-blue, brown-yellow) : 100~200Ω
			The cooling capacities of indoor units except for the relevant indoor unit are insufficient. Abnormal sound is heard from indoor unit.	Electronic expansion valve opening of the relevant indoor unit is out of control (open excessively) during cooling operation.	The area (heat exchanger) near the air diffuser is cool even after several minutes have elapsed since the relevant indoor unit was stopped. (the gas pipe of the relevant indoor unit remains cold).	When the electronic expansion valve is open excessively, other indoor units may not operate at full capacity or a loud refrigerant rushing sound may be generated. If the electronic expansion valve of the stopping indoor unit remains open, frost may form on the surface of the heat exchanger of the indoor unit and water leakage or other trouble may occur.
			Abnormal sound is heard from indoor unit. Frost may form on the surface of the heat exchanger of the relevant indoor unit. □	Electronic expansion valve opening of the relevant indoor unit is out of control (open excessively) after stopping cooling operation.		Turn off the power source of PCB of the indoor unit to initialize the electronic expansion valves for several times. Put a 3-minute interval between each initializations. The electronic expansion valve may return to normal.
			The heating capacities of indoor units except for the relevant indoor unit are insufficient. Abnormal sound is heard from indoor unit.	Electronic expansion valve opening of the relevant indoor unit is out of control (open excessively) during heating operation.	The temperature of air flow as well as inlet pipe of the electronic expansion valve of the relevant indoor unit is higher than those of other indoor units.	Turn off the power source of PCB of the indoor unit to initialize the electronic expansion valves for several times. Put a 3-minute interval between each initializations. The electronic expansion valve may return to normal.
				Electronic expansion valve opening of the relevant indoor unit is out of control (open excessively) when the indoor unit stop heating operation.	The temperature of inlet pipe of the electronic expansion valve do not become low.	
			Discharge temperature is high.	Up/down (left/right) swing switching motor is faulty.	Up/down louver does not move even when a voltage (DC12V) is applied to the terminal of CN10 (for wall mounted and ceiling wall type: CN6). Check the voltage across the terminal.	For the left - right swing switching motor, check the voltage across the terminal of CN11. (for wall mounted and ceiling wall type: CN7).
			Discharge temperature is high. ※Remakes	Liquid injection solenoid valve (SV1) is faulty.	When a voltage (AC220-240V) is applied to CN7, the liquid injection solenoid valve outlet pipe is not cold.	When SV1 is faulty, the discharge gas temperature may rise and a discharge temperature error may be generated. Coil resistance : 1200~1500Ω.
				High pressure gas bypass solenoid valve (SV2) is faulty.	When a voltage (AC220-240V) is applied to CN8, the high pressure gas bypass solenoid outlet pipe is not warm.	When SV2 is faulty, the high pressure may rise and a high pressure error may be generated. Coil resistance : 1200~1500Ω
			Compressor error ※Remakes	Oil return solenoid valve (SV3, SV4, SV5, SV6) is faulty.	When a voltage (AC220-240V) is applied to CN9, CN10, CN11, and CN12, the outlet pipe of the respective solenoid valve (SV3, SV4, SV5, SV6) does not become hot.	When SV3, SV4, SV5, and SV6 do not operate normally, the oil may not return to the compressor and compressor trouble may occur. Coil resistance : 1200~1500Ω
			High pressure is high. ※Remakes	High pressure switch is faulty.	There is a voltage difference across terminals 1-2 of CN42 even though the high pressure exceeds 3.0MPa.	When the pressure switch is faulty, protection control will not be performed even if the high pressure rises and a high pressure error may be generated.
Error display (Outdoor unit error)	Error display (Discharge sensor error)	Error display (Outdoor unit error)	The operation of the outdoor unit is abnormal. ※Remakes	Pressure sensor (HP, LP) are faulty.	Measure the pressure sensors output voltage (between terminals 2 and 3 of CN33 and CN34) and compare the result with the pressure gauge indication.	When the pressure sensors are faulty, compressor steps and protection control will not be conducted properly. Refer to 7-2-2 to find the correlation between pressure and output voltage of the sensor.

5-6 CASES SUCH AS THESE ARE NORMAL

■ Operation not trouble

From the stand point of control, the following operations are incorporated for air conditioner operation and protection. They do not indicate trouble.

Operation	Description	Indoor unit	Remote indication
Red and green lamps flash alternately, or simultaneously.	Indicates that the power came on normally when power was applied (at power failure recovery). Indication is cleared by RUN command.	The red and green lamps flash alternately in the operation stop state.	
	When test run is performed, the unit operates without regard to the temperature setting. Stopped by remote controller stop, or reset after 60 minutes maximum.	The red and green lamps flash simultaneously in the operation state.	TEST
Red lamp flashes.	Operation is stopped and refrigerant is passed through the indoor unit to remove the outdoor unit frost (defrosting operation) or to recover the refrigerant oil (oil recovery operation). The indoor unit stops in about 5-10 minutes.	The fan stops and the refrigerant passes through. The red lamp flashes slowly.	DEFROST
Indoor unit fan does not operate even through the RUN signal has entered.	The fan is stopped to prevent blowing out of cold air when the machine is still not warm at the start of heating operation. About 3 minutes are necessary.	The fan stops and the red lamp lights steadily.	
Fan turns on/off periodically.	When the room temperature at heating operation reaches the set temperature, the FAN is stopped and room temperature rise is prevented. At this time, the fan is operated periodically to detect the room temperature. (4 minutes stop, 1minute operate)	The fan continues to operate and the red lamp lights steadily.	
Remote controller airflow indication flashes.	This is the filter cleaning time. After cleaning the filter, press the ZONE/SET key for a few seconds to be released .	Same as normal.	Airflow indication flashes
Heating operation is performed when stopped.	Anti-freeze operation is set so that the water pipe and electronic devices do not freeze. Operation starts at room temperature 5°C or less and continues until the room temperature reaches 8°C or more.	At standby, the red lamp flashes and the fan continues to operate. At operation, the heating operation is performed.	ANTIFREEZE
RUN signal is input, but is not accepted. Buzzer sounds.	When operation is inhibited during central control by central remote controller, the buzzer that denies the wireless remote controller signals sounds.	Buzzer buzzes 5 times and setting is not received. Operation before setting continues.	CENTRAL
	When an [AUTO], [FAN] and an operation other than the operation another indoor unit is already performing at cooling/heating selection type or [HEAT] operation at a cooling only unit is commanded, operation cannot be performed at that setting.	Buzzer buzzes 5 times and setting is not received. Operation before setting continues.	
	Timer setting cannot be performed by wireless remote controller at an indoor unit with wired remote controller connected. Set the timer from the wired remote controller.	Buzzer buzzes 5 times and setting is not received. Operation before setting continues.	
Makes a sound even after operation stops.	The valve opens to return the refrigerant collected inside the indoor unit to the outdoor unit even after operation stops. Remains for about 4 minutes maximum.		
	After cooling operation stops, the drain pump is operated. Remains for 3 minutes.		
Makes a sound while operating.	Flowing liquid sound during operation	A sound changed by the refrigerant flow may be made by operation of another indoor unit connected to the same outdoor unit. A switching sound may be made at the start and after the end of defrosting operation and oil recovery operation.	
	Squeaking sound	This is due to expansion and contraction of resin parts by the temperature change during heating operation and oil recovery operation.	
	Switching sound	A sound is generated when the internal valve is switched at operation switching and at the start of defrosting operation and oil recovery operation.	

When operation and indication other than the above occurs, call the manager.

Refrigerant
R407C

AIRSTAGE™

6 . APPENDING DATA 1 (INSTALLATION)

6. APPENDING DATA1 (INSTALLATION)

6-1 ADDITIONAL CHARGE

(1) Indoor unit model type

Refrigerant must be added to all connected indoor units.

Add refrigerant as shown in the Table for every indoor unit connected to the refrigerant system.

Example : When AR_30TFCMF x 2 and AU_18TFCMF x 2 are connected to the refrigerant system.

" Additional charge of Indoor unit model type" is $1.0(\text{kg})\times 2 + 0.45(\text{kg})\times 2 = 2.9(\text{kg}) \dots (1)$

Model / Model code	7	9	12	14	18	20	24/25	30	36	45	54	60
AS(_ _ _TFAMF)	0.5	0.5	0.9	0.9	—	0.9	0.9	0.9	—	—	—	—
AU(_ _ _TFAMF)	0.65	0.65	0.65	0.65	0.65	0.8	0.8	0.8	1.5	1.5	1.5	—
AB(_ _ _TFAMF)	—	—	0.65	0.65	0.65	—	1.0	1.0	1.0	1.0	1.0	—
AR(_ _ _TFAMF)	0.4	0.4	0.45	0.45	0.7	—	1.0	1.0	2.0	2.0	—	—
AU(_ _ _TFBMF)	0.45	0.45	0.45	0.45	0.45	—	—	—	—	—	—	—
AR(_ _ _TFBMF)	—	—	—	—	—	—	—	—	2.0	2.0	—	2.0
AS(_ _ _TFCMF)	0.3	0.3	0.3	0.3	0.6	—	0.6	0.6	—	—	—	—
AW(_ _ _TFCMF)	0.35	0.35	0.6	0.6	0.6	—	0.6	0.6	—	—	—	—
AU(_ _ _TFCMF)	0.45	0.45	0.45	0.45	0.45	1.2	1.2	1.2	1.5	1.5	1.5	—
AB(_ _ _TFCMF)	—	—	0.65	0.65	0.65	—	1.0	1.0	1.0	1.0	1.0	—
AR(_ _ _FCMF)	0.4	0.4	0.45	0.45	0.7	—	1.0	1.0	2.0	2.0	—	2.0

Amount of refrigerant (kg)

(2) Pipe length

- * Up to a liquid pipe length of 7.5 m, charging with additional refrigerant is not necessary.
- * If the liquid pipe length exceeds 7.5m, please calculate the additional charge amount. After calculating the total amount of charging required, subtract the original refrigerant amount of 0.75kg.

Liquid pipe (mm)	ϕ 12.7	ϕ 9.53	ϕ 6.35
Additional refrigerant (kg/m)	0.1	0.05	0.02

The amount of additional charge C(kg)

$$C = \left[\begin{array}{|c|c|} \hline \text{Total length} & \times 0.1 \\ \text{of } \phi 12.7\text{mm} & \text{kg/m} \\ \text{liquid pipe} & \\ \hline \text{m} & \\ \hline & \text{kg} \\ \hline \end{array} \right] + \left[\begin{array}{|c|c|} \hline \text{Total length} & \times 0.05 \\ \text{of } \phi 9.53\text{mm} & \text{kg/m} \\ \text{liquid pipe} & \\ \hline \text{m} & \\ \hline & \text{kg} \\ \hline \end{array} \right] + \left[\begin{array}{|c|c|} \hline \text{Total length} & \times 0.02 \\ \text{of } \phi 6.35\text{mm} & \text{kg/m} \\ \text{liquid pipe} & \\ \hline \text{m} & \\ \hline & \text{kg} \\ \hline \end{array} \right] - 0.75 = \boxed{(2)}$$

Round up C to 2 decimal place.

If C is zero or less, Charging with additional refrigerant is not required.

Example : When the liquid pipe length $\phi 12.7\text{mm} = 10\text{m}$, $\phi 9.53\text{mm} = 15\text{m}$, $\phi 6.35\text{mm} = 20\text{m}$

" Additional charge of pipe length " is

$$10(\text{m})\times 0.1(\text{kg/m}) + 15(\text{m})\times 0.05(\text{kg/m}) + 20(\text{m})\times 0.02(\text{kg/m}) - 0.75(\text{kg})^*$$

$$= 1.4(\text{kg}) \dots (2)$$



*As 0.75kg of refrigerant is originally provided inside the outdoor unit for liquid pipe length of 7.5m, it is necessary to subtract this 0.75kg from the calculation.

ADDITIONAL CHARGE = (1) + (2)

6-2 ADDRESS SETTING

- With this system, an address must be set for the indoor unit, outdoor unit and remote controller and central remote controller.

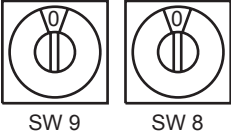
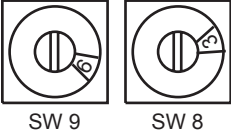
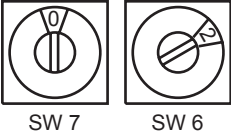
6-2-1 KINDS OF ADDRESS AND SETTING RANGE

UNIT	SETTING	SETTING RANGE	TYPE OF SWITCH	REMARKS
Outdoor unit	Refrigerant circuit address	0~99	Setting example 0  SW 9 SW 8	Shown in the next page
Indoor unit ¹⁾	Refrigerant circuit address	0~99	Setting example 63  SW 9 SW 8	
	Indoor unit address	0~15	Setting example 2  SW 7 SW 6	Always SW 7 set "0"
	Remote controller address	0~15	Setting example 0  SW 10	
Remote controller (wired,simple)	Remote controller switch 1	ON/OFF	DIP SW1-1	OFF : Not terminated ON : Terminated
	Number of indoor unit connection	ON/OFF	DIP SW1-2	Number of indoor unit OFF : 1 unit ON : multiple unit
	Remote controller switch 2	ON/OFF	DIP SW1-4	OFF : Master ON : Slave
Central remote controller	Central remote controller address	0 ~ 15	Initial setting	

1) For compact wall mounted type indoor unit, refer to 6-2-2.

● Refrigerant circuit address conversion table

Outdoor unit

Rotary switch (SW 8)- - - Factory setting "0"

Rotary switch (SW 9)- - - Factory setting "0"

Indoor Unit

Rotary switch (SW 8)- - - Factory setting "0"

Rotary switch (SW 9)- - - Factory setting "0"

In the case of a multiple refrigerant system, each refrigerant system (outdoor unit and indoor unit) must be set an exclusive refrigerant circuit address.

Please use the rotary switches(SW8,SW9) to set the address.A conversion table of refrigerant circuit address and rotary switch setting is shown in the table below.

Do not use a nonexistent switch setting combination.

Example : When SW 9 is set to "1" and SW 8 is set to "14" the refrigerant circuit address will be "30".

Refrigerant circuit address	Rotary Switch setting		Refrigerant circuit address	Rotary Switch setting		Refrigerant circuit address	Rotary Switch setting		Refrigerant circuit address	Rotary Switch setting		Refrigerant circuit address	Rotary Switch setting	
	SW9	SW8		SW9	SW8		SW9	SW8		SW9	SW8		SW9	SW8
0	0	0	20	1	4	40	2	8	60	3	12	80	5	0
1	0	1	21	1	5	41	2	9	61	3	13	81	5	1
2	0	2	22	1	6	42	2	10(A)	62	3	14	82	5	2
3	0	3	23	1	7	43	2	11(B)	63	3	15	83	5	3
4	0	4	24	1	8	44	2	12(C)	64	4	0	84	5	4
5	0	5	25	1	9	45	2	13(D)	65	4	1	85	5	5
6	0	6	26	1	10(A)	46	2	14(E)	66	4	2	86	5	6
7	0	7	27	1	11(B)	47	2	15(F)	67	4	3	87	5	7
8	0	8	28	1	12(C)	48	3	0	68	4	4	88	5	8
9	0	9	29	1	13(D)	49	3	1	69	4	5	89	5	9
10	0	10(A)	30	1	14(E)	50	3	2	70	4	6	90	5	10(A)
11	0	11(B)	31	1	15(F)	51	3	3	71	4	7	91	5	11(B)
12	0	12(C)	32	2	0	52	3	4	72	4	8	92	5	12(C)
13	0	13(D)	33	2	1	53	3	5	73	4	9	93	5	13(D)
14	0	14(E)	34	2	2	54	3	6	74	4	10(A)	94	5	14(E)
15	0	15(F)	35	2	3	55	3	7	75	4	11(B)	95	5	15(F)
16	1	0	36	2	4	56	3	8	76	4	12(C)	96	6	0
17	1	1	37	2	5	57	3	9	77	4	13(D)	97	6	1
18	1	2	38	2	6	58	3	10	78	4	14(E)	98	6	2
19	1	3	39	2	7	59	3	11	79	4	15(F)	99	6	3

6-2-2 ADDRESS SETTING FOR COMPACT WALL MOUNTED TYPE INDOOR UNIT

KINDS OF ADDRESS AND SETTING RANGE

SETTING	SETTING RANGE	TYPE OF SWITCH	REMARKS
Refrigerant circuit address	0~99	<p>DIP-SW 3 Rotary - SW 5</p> <p>Setting example: 16</p>	See refrigerant address conversion table below
Indoor unit address	0~15(F)	<p>DIP-SW 2 Rotary - SW 4</p> <p>Setting example: 3</p>	Always set DIP SW 2-1 and 2-2 to "OFF"
Remote controller address	—	No such a switch	A setup is impossible.

• Refrigerant address conversion table

Refrigerant circuit address	DIP-SW			Rotary -sw sw5	Refrigerant circuit address	DIP-SW			Rotary -sw sw5	Refrigerant circuit address	DIP-SW			Rotary -sw sw5	Refrigerant circuit address	DIP-SW			Rotary -sw sw5
	3-1	3-2	3-3			3-1	3-2	3-3			3-1	3-2	3-3			3-1	3-2	3-3	
0	OFF	OFF	OFF	0	25	ON	OFF	OFF	9	50	ON	ON	OFF	2	75	OFF	OFF	ON	11(B)
1	OFF	OFF	OFF	1	26	ON	OFF	OFF	10(A)	51	ON	ON	OFF	3	76	OFF	OFF	ON	12(C)
2	OFF	OFF	OFF	2	27	ON	OFF	OFF	11(B)	52	ON	ON	OFF	4	77	OFF	OFF	ON	13(D)
3	OFF	OFF	OFF	3	28	ON	OFF	OFF	12(C)	53	ON	ON	OFF	5	78	OFF	OFF	ON	14(E)
4	OFF	OFF	OFF	4	29	ON	OFF	OFF	13(D)	54	ON	ON	OFF	6	79	OFF	OFF	ON	15(F)
5	OFF	OFF	OFF	5	30	ON	OFF	OFF	14(E)	55	ON	ON	OFF	7	80	ON	OFF	ON	0
6	OFF	OFF	OFF	6	31	ON	OFF	OFF	15(F)	56	ON	ON	OFF	8	81	ON	OFF	ON	1
7	OFF	OFF	OFF	7	32	OFF	ON	OFF	0	57	ON	ON	OFF	9	82	ON	OFF	ON	2
8	OFF	OFF	OFF	8	33	OFF	ON	OFF	1	58	ON	ON	OFF	10(A)	83	ON	OFF	ON	3
9	OFF	OFF	OFF	9	34	OFF	ON	OFF	2	59	ON	ON	OFF	11(B)	84	ON	OFF	ON	4
10	OFF	OFF	OFF	10(A)	35	OFF	ON	OFF	3	60	ON	ON	OFF	12(C)	85	ON	OFF	ON	5
11	OFF	OFF	OFF	11(B)	36	OFF	ON	OFF	4	61	ON	ON	OFF	13(D)	86	ON	OFF	ON	6
12	OFF	OFF	OFF	12(C)	37	OFF	ON	OFF	5	62	ON	ON	OFF	14(E)	87	ON	OFF	ON	7
13	OFF	OFF	OFF	13(D)	38	OFF	ON	OFF	6	63	ON	ON	OFF	15(F)	88	ON	OFF	ON	8
14	OFF	OFF	OFF	14(E)	39	OFF	ON	OFF	7	64	OFF	OFF	ON	0	89	ON	OFF	ON	9
15	OFF	OFF	OFF	15(F)	40	OFF	ON	OFF	8	65	OFF	OFF	ON	1	90	ON	OFF	ON	10(A)
16	ON	OFF	OFF	0	41	OFF	ON	OFF	9	66	OFF	OFF	ON	2	91	ON	OFF	ON	11(B)
17	ON	OFF	OFF	1	42	OFF	ON	OFF	10(A)	67	OFF	OFF	ON	3	92	ON	OFF	ON	12(C)
18	ON	OFF	OFF	2	43	OFF	ON	OFF	11(B)	68	OFF	OFF	ON	4	93	ON	OFF	ON	13(D)
19	ON	OFF	OFF	3	44	OFF	ON	OFF	12(C)	69	OFF	OFF	ON	5	94	ON	OFF	ON	14(E)
20	ON	OFF	OFF	4	45	OFF	ON	OFF	13(D)	70	OFF	OFF	ON	6	95	ON	OFF	ON	15(F)
21	ON	OFF	OFF	5	46	OFF	ON	OFF	14(E)	71	OFF	OFF	ON	7	96	OFF	ON	ON	0
22	ON	OFF	OFF	6	47	OFF	ON	OFF	15(F)	72	OFF	OFF	ON	8	97	OFF	ON	ON	1
23	ON	OFF	OFF	7	48	ON	ON	OFF	0	73	OFF	OFF	ON	9	98	OFF	ON	ON	2
24	ON	OFF	OFF	8	49	ON	ON	OFF	1	74	OFF	OFF	ON	10(A)	99	OFF	ON	ON	3

6-2-3 EXAMPLES OF SYSTEM SETTING

The following examples apply to all indoor units except for compact wall mounted type indoor unit.

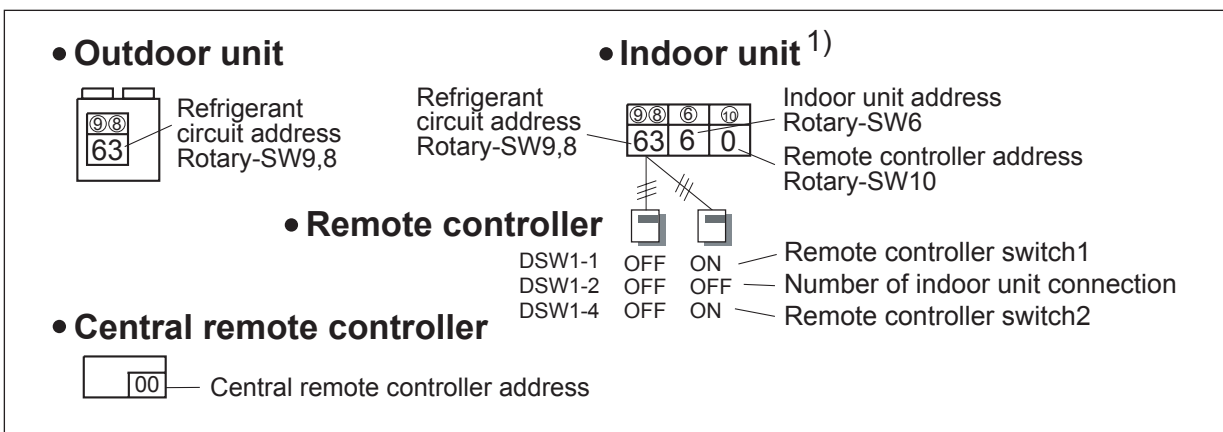
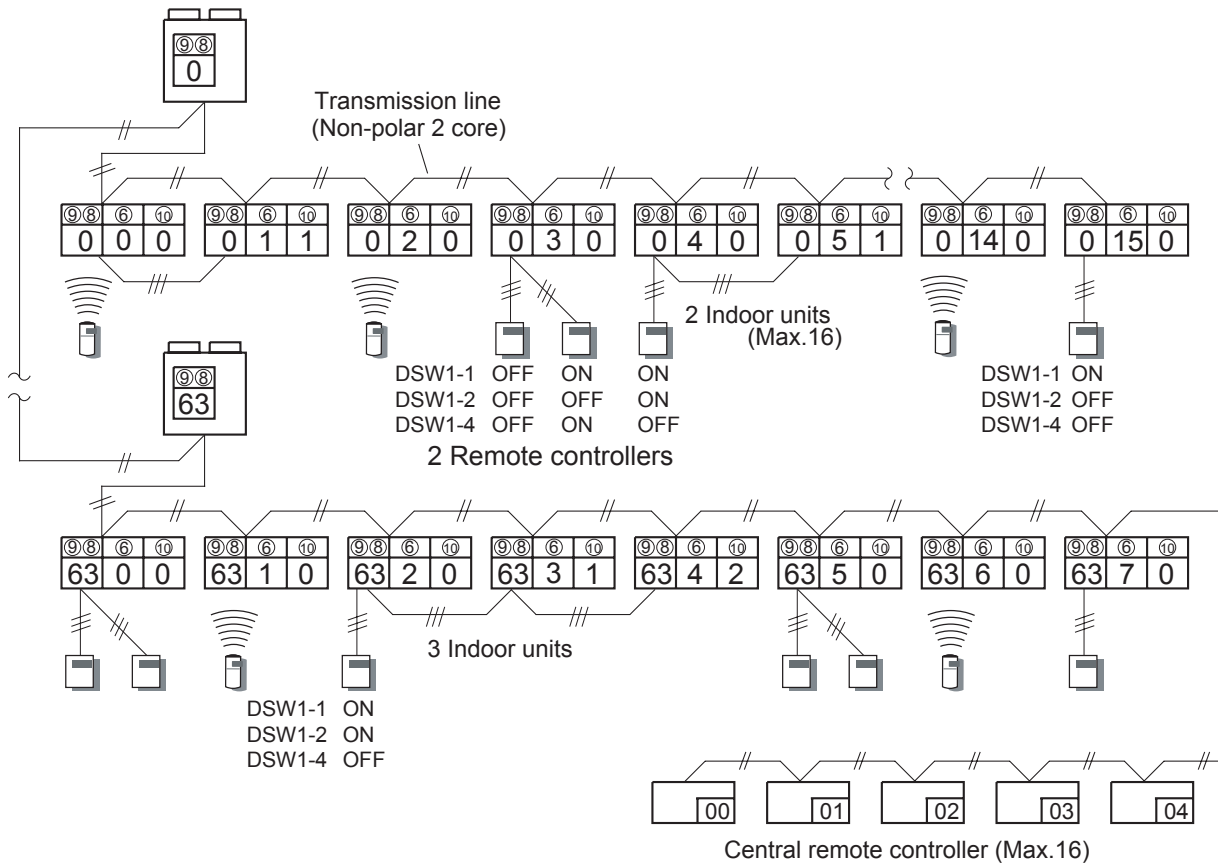

1) For compact wall mounted type indoor unit, refer to 6-2-2.

※ Instructions for setting up the address

1 The Refrigerant circuit address of the indoor and outdoor units can be set to optional numbers in the range of 0 to 99.

2 The Indoor unit address can be set to optional numbers in the range of 0 to 15.

3 Set the Remote controller address in the order of 0,1,2,...15.(Blank is impossible)

4 The Central remote controller address can be set to optional numbers in the range of 0 to 15.

① Refrigerant circuit address (Outdoor unit)

② Refrigerant circuit address (Indoor unit)

Refrigerant circuit 1

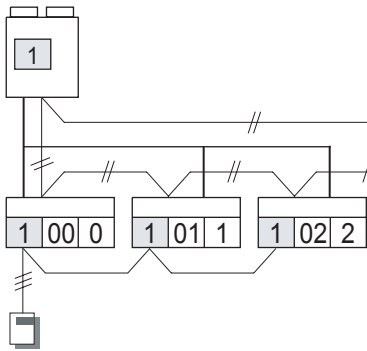

Outdoor unit PCB (Address setting No.0~99)
Setting by rotary SW8,9

Refrigerant circuit 2

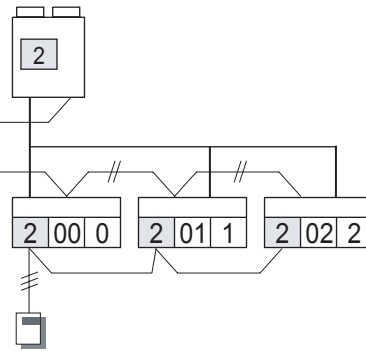

Indoor unit PCB (Address setting No.0~99)
Setting by rotary SW8,9
For compact wall mounted type indoor unit,
refer to 6-2-2.

③ Indoor unit address

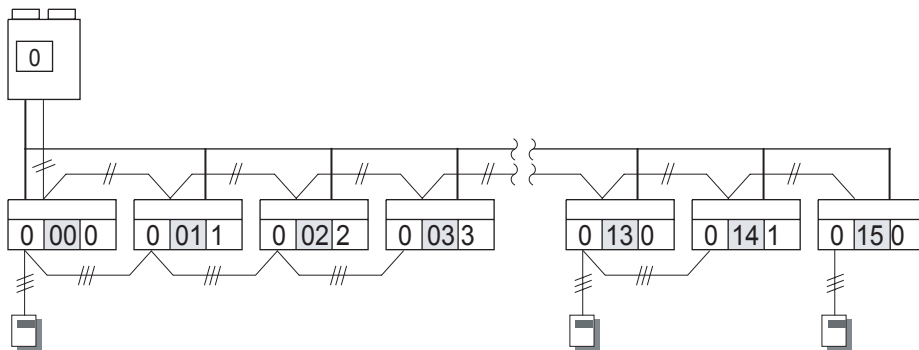

Indoor unit PCB (Address setting No. 0~15)
Setting by rotary SW6, SW7
(Always set Rotary SW7 at 0)
For compact wall mounted type indoor unit,
refer to 6-2-2.

④ Remote controller address (Indoor unit)

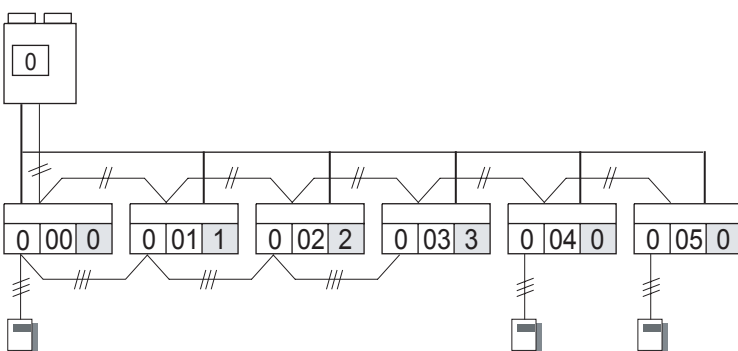

Indoor unit PCB (Address setting No.0~15)
Setting by rotary SW10

⑤ Remote controller switch 1

If 2 sets of wired remote controllers are connected to the remote control group, turn the DIP SW 1-1 of Master Remote Controller off.

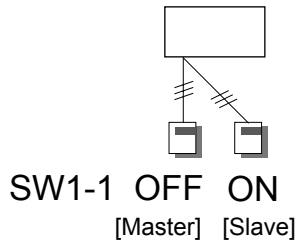

Remote controller unit PCB
Setting by DIP SW 1-1

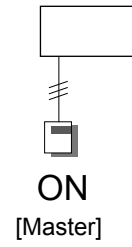

When only 1 remote controller will connect,
this switch must be set ON.

⑥ Number of indoor unit connection

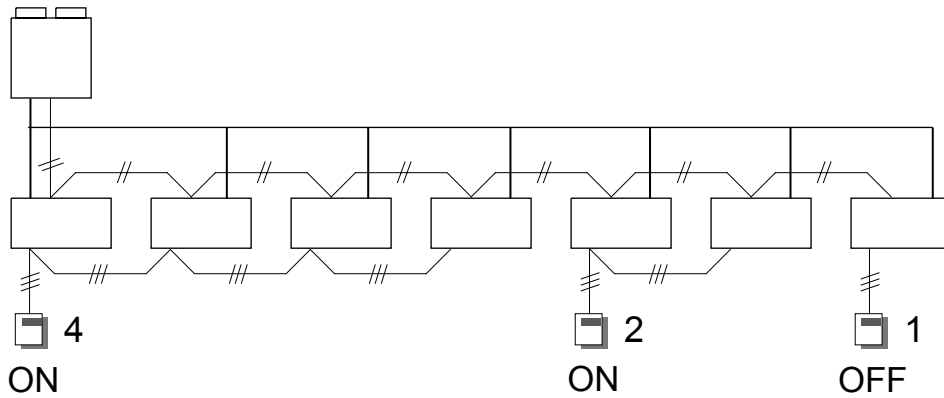

Remote controller PCB
Setting by DIP SW 1-2

⑦ Remote controller switch 2 (Remote controller)

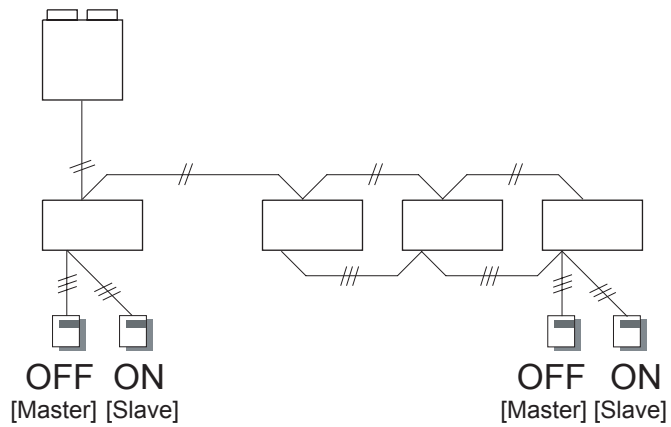

Remote controller unit PCB

Setting by DIP SW 1 - 4

⑧ Central remote controller address

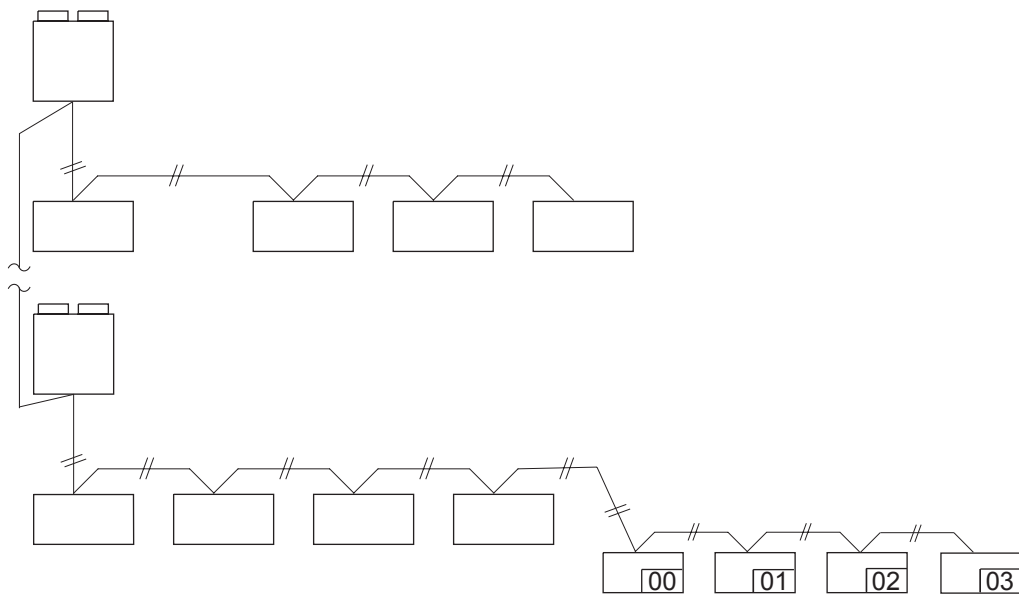

Central remote controller (Max. 16)

* Set central remote controller address first, to conduct the initial setting of it.

6-3 PUMP DOWN METHOD

6-3-1 START AND STOP OF THE PUMP DOWN

(1) If the following condition is satisfied, pump down operation will start.

When the operation mode is stopped and pump down DIP-SW 1-3 turns OFF → ON.

(2) Pump down operation stops immediately in the following cases.

- When pump down DIP-SW is turned ON → OFF
- When the discharge pressure sensor detects a pressure higher than 3MPa.

6-3-2 A FLOW CHART OF PUMP DOWN

■ OUTDOOR UNIT

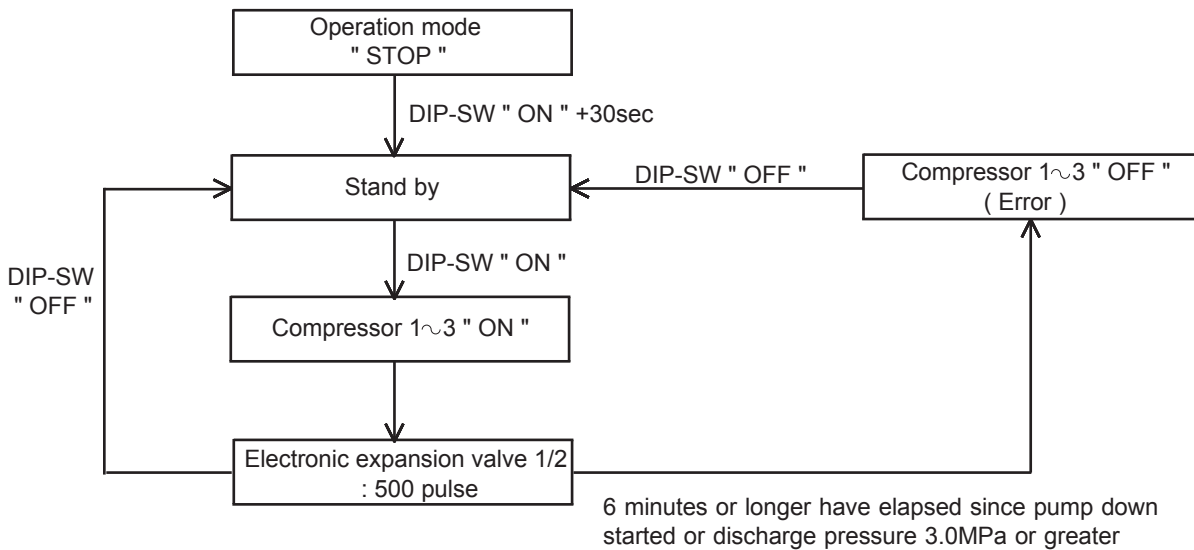

■ INDOOR UNIT

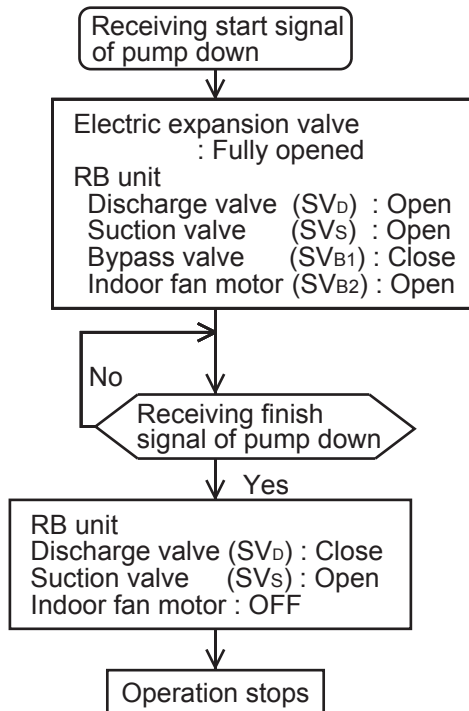

Gauge manifold (Fig.4-1)
Pressure gauge changed.

Charge hose (Fig.4-2)
Changed to HFC resistant material.

Refrigerant cylinder (Fig.4-3)
Confirm the refrigerant type before charging. Always charge liquid-phase refrigerant.

Electronic balance for refrigerant charging (Fig.4-4)
Electronic balance is recommended as in the case of R410A.

Vacuum pump with adapter to prevent reverse flow (Fig.4-5)
Conventional pump can be used.

Vacuum holder (Fig.4-6)
Conventional pump can be used if adapter for preventing vacuum pump oil from flowing back is used.

Gas leakage tester (Fig.4-7)
Exclusive for HFC

Refrigerant cleaner (Fig.4-8)
Brown paint as designated by the ARI, USA

Flare tool (Fig.4-9)
Conventional tool can be used.

Torque wrench (Fig.4-10)
Conventional wrench can be used.

Refrigerant recovering equipment (Collector) (Fig.4-11)
The type which can be used for any refrigerant is available

Nitrogen cylinder (Fig.4-12)
This prevents an oxide film from forming in the pipe silver-alloy brazing work by turning the air out of the pipe and preventing the inside combustion.

Safety charger (Fig.4-13)
It is always compulsory to change the liquid, because R407C is a mixed refrigerant and there is some fear that a mixing ratio changes. In order to avoid the refrigerant from returning to the compressor in a liquid state, the refrigerant can be charged instead of giving a load to the compressor with a safety charger.

Control valve (Fig.4-14)
The control valve prevents the refrigerant from spouting when it is removed, as the charging hose side and the service port side are possible to open and close at the same time.

Thermistor vacuum gauge (Fig.4-15)
To remove moisture from the refrigerating cycle completely, it is necessary to perform appropriate vacuum drying. For that reason, vacuum conditions can be confirmed certainly.

Vacuum valve (Fig.4-16)
This valve builds in a check valve, and it is easily possible to vacuum a refrigerating cycle or check for degree of vacuum with it.

TOOLS AND EQUIPMENT (R407C)

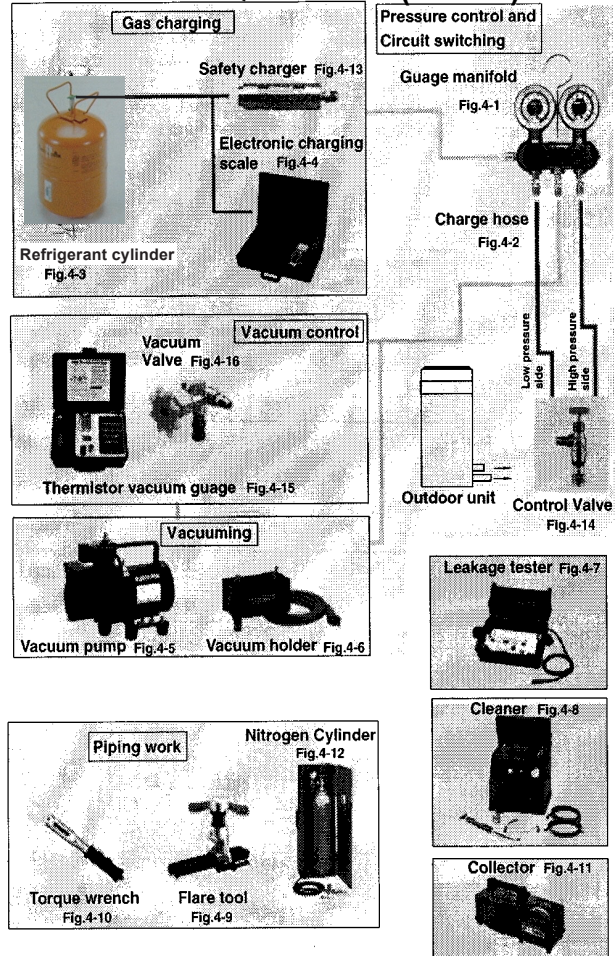

6-5 PRECAUTIONS FOR INSTALLATION

1. Preparing pipes

- (1) Use the designated size (diameter & thickness) of refrigerant pipes.
- (2) Those pipes purchased locally may contain dust inside. Please blow out the dust by dried inert gas when using.
- (3) Be careful to avoid the dust or water falling into the pipe when performing piping process and piping installation.
- (4) When processing the pipe, make the number of bending portion as few as possible, and the bending radius as large as possible.

Diameter and thickness of copper pipes is shown below.

Nominal diameter (inch)	Outer diameter (mm)	Thickness (mm)
1/4	ø 6.35	0.8
3/8	ø 9.52	0.8
1/2	ø 12.70	0.8
5/8	ø 15.88	1.0
3/4	ø 19.05	1.0
1 1/8	ø 28.58	1.2

- (5) To process the branch, do not use T-shaped pipe, which causes an uneven refrigerant flow. Use the optionally available standard branch kit.
- (6) If the diameter of the required pipe is different from the branch unit, either cut it out or use the reducer.

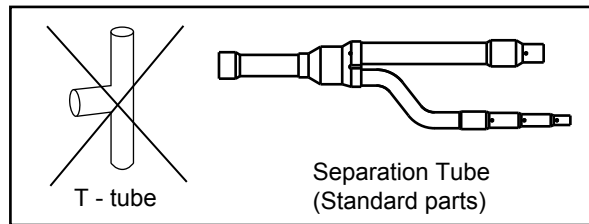

- (7) Keep the permissible length of every piping limitation to prevent a defect or cooling/heating failure.
- (8) When replacing the unit, never use piping which has been used for previous installations. Only use the new piping.

2. Flare connection

- (1) Confirm that there are not scratches or waster, etc., on the flare and union surface.
- (2) When using lubrication oil on the inside and outside of flare, always use small amount and must the same lubrication oil as used in the refrigerant circuit. Use of different oil will cause the lubrication oil to deteriorate and a compressor failure. Also too much oil may introduce water inside refrigerant circuit because the synthetic oil is highly hygroscopic.

3. Brazing work

Brazing work must be carried out while blowing dry nitrogen gas through the pipes, so that an oxidized layer does not form on the inner surface of the pipes.

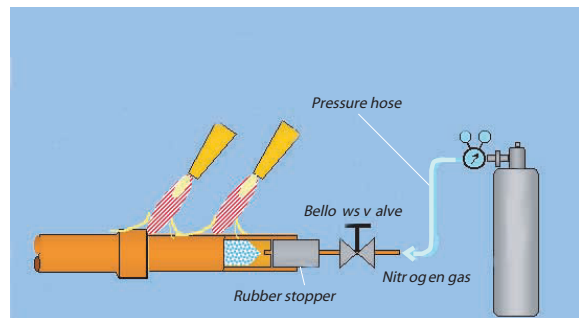

Example) Inside state of welded pipe section

Nitrogen Gas is used



Nitrogen Gas is used but not sufficient (Oxygen gas still exists inside the pipe)



Nitrogen Gas is not used



4. Tightness test

- (1) After completing all piping connection, always carry out an air tight test to check and confirm that there is no gas leakage. Charge the piping with nitrogen to within the sealing test pressure (2.94 MPa). After 24 hours, check that the pressure has not fallen. Make sure to add the pressure to both gas pipe and liquid pipe. Perform the leak test on all flared and brazed parts.

Note: When the ambient temperature changes 5 deg. , the test pressure changes 0.05MPa.

- (2) After tightness test, please insulate the connecting portion, apply the enough insulation to avoid any gap.

5. Vacuum process

- (1) Do not purge the air with refrigerant but use a vacuum pump to remove air from the indoor units and connection pipes!
- (2) Remove the cap, and connect the gauge manifold and the vacuum pump to the charging valve by the service hoses.
- (3) Vacuum the indoor unit and the connecting pipes until the pressure gauge indicates -76 cmHg.
- (4) When -76 cmHg is reached, operate the vacuum pump for at least 1 hour.
- (5) After vacuuming inside the indoor unit and connecting pipes,remove the cap of the two valves.
- (6) Open the handle (spindle) of the Large and middle valves(Ball valve).
Open the spindle of the Small valve(3 way valve) with a hexagon wrench.
- (7) Tighten the cap of the two valves to the specified torque.

	Tightening torque	
	Ball valve	3 way valve
Spindle (handle)	15 kgf•cm (1.47 N•m) or less	100 to 120 kgf•cm (9.8 to 11.7 N•m)
Cap	150 to 200 kgf•cm (14.7 to 19.6 N•m)	200 to 250 kgf•cm (19.6 to 24.5 N•m)

Ball valve (Suction Gas)

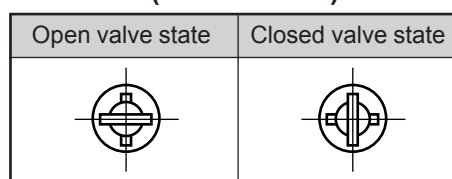

Ball valve (Discharge Gas)

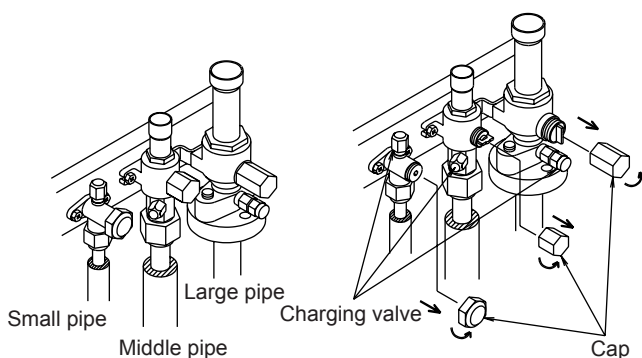
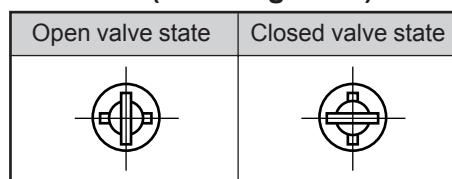

3 way valve

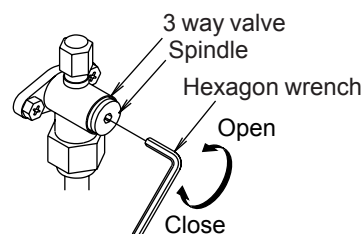

If the spindle (handle) is not fully open, performance will degrade and an abnormal sound will be generated.

6. Additional charge

- (1) Be careful, don't charge with wrong refrigerant!
- (2) When moving and installing the air conditioner, do not mix gas other than the specified refrigerant inside the refrigerant circuit.
- (3) When charging the refrigerant, always use an electronic balance for refrigerant charging. (to measure the refrigerant by weight)
- (4) R407C is a mixture of 3 refrigerants with different evaporation temperature. The composition changes if it is charged in gas phase. Therefore always charge from the liquid phase side whose composition is stable.
- (5) Always add the refrigerant for the appropriate amount. (For the calculation method, please refer to 6-1"ADDITIONAL CHARGE")
- (6) Either larger or smaller refrigerant charge amount leads to the cause of trouble.
- (7) For after service purpose, the added refrigerant charge amount and the calculation shall be indicated firmly on the service label over the control box cover.

7. Other installation information

Please refer to (DESIGN & TECHNICAL DATA) to find more detailed installation information on installation the outdoor unit, on installation space, on electrical wiring and drain processing.

6-6 PRECAUTIONS FOR SERVICING

1. Countermeasure when the refrigerant leaks

As R407C is zeotropic refrigerant, the composition of the remaining refrigerant changes when the refrigerant leaks. Therefore, recharging refrigerant cannot be done. Recover the remaining refrigerant and charge the specified amount of new refrigerant.

2. Never use the existing refrigerant piping

The existing piping used for R22 cannot be used for HFC series refrigerant as the conventional mineral oils are adhering to the piping. If new synthetic oil is mixed with residual oil (ex : mineral type), they may deteriorate, and block the capillary tubes, or cause a compressor failure. Therefore, basically use a brand new pipe. However, in the case of the existing piping buried in the wall and replacement with new piping is difficult, wash the piping fully with detergent. It is desirable that the amount of residual oil in connection pipes is less than 40mg/10m.

3. Replacement of refrigeration circuit parts

As refrigerant circuit parts are basically different from conventional parts, be sure to use the parts suitable for the refrigerant when replacing. For R407C, the materials should be reviewed.

4. Check not to charge with wrong refrigerant

As there are air conditioner models using different refrigerant such as R22, R407C, make sure not to use wrong refrigerant when installing and servicing.

5. Storage of parts

When storing parts, make such treatment as packing the parts in bags so as to avoid dusts, water, etc.

6. Replacing parts

When replacing parts, be sure to check if the parts are suitable for the refrigerant (model). Although many refrigeration circuit parts have same appearance, however, their inside materials are different.

When changing compressor, complete brazing work within 15 minutes after removing the compressor cap. Because the moisture in air will enter the compressor and the new synthetic oil will absorb the moisture causing sludge.

When changing dryer, complete brazing work within one hour after the package of dryer is opened, because the desiccant starts to absorb the water content as soon as the package of dryer is opened. If it absorbs too much water content when replacing, it cannot absorb fully the water content in the refrigerating circuit.

6-7-1 WHAT IS CFC/HCFC/HFC ?

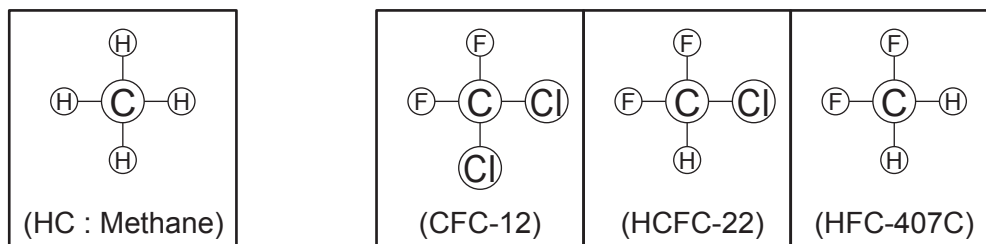

- CFC : Chloro-Fluoro-Carbon
= high ODP(ozone depletion potential) chemical compound containing chlorine (ODP: 0.6 - 1.0)
- HCFC : Hydro-Chloro-Fluoro-Carbon (R22)
= low ODP chemical compound containing chlorine and hydrogen (ODP:1/10 - 1150 of CFC)
- HFC : Hydro-Fluoro-Carbon (R407C)
= zero ODP new chemical compound in which is not containing chlorine (ODP: 0)

6-7-2 CHARACTERISTICS OF R22 AND R407C

HANDLING

As in the case of R22, the specific gravity of its vapor is larger than that of air and should it leak in an air-tight room it may stay at a low level and cause oxygen starvation accident.

If a fire is used in R407C existing area, a poisonous gas will occur, so be sure to handle it only in a well ventilated area.

SELECTION OF REFRIGERANT

As there is no appropriate mono-constituent refrigerant to replace R22 which has been used for conventional air conditioners, the mixed refrigerant of HFC series was developed.

R407C

Merits

As working pressure is nearly equal to R22 (about 1.1 times), pressure resistance design is easy.

- Discharge compressor
 - Max. 30.0 bar for reciprocating compressor
 - Max. 28.5 bar for rotary compressor

Demerits

Composition control is necessary for charging refrigerant as it is zeotropic refrigerant.

- When leaked, it will become composition of more R134a constituent with high boiling point.
Also, charging refrigerant must be done from the liquid phase side.
Review of control system is required as there is temperature glide.
- R407C is used for large air conditioners.
Pressure resistance design is easy and safe.

	R22	R407C
Composition (wt%)	R22 (100)	R32/R125/R134a (23/25/52)
Boiling point	-40.8	-43.6
Ozone depletion potential ODP	0.055	0
Global warming potential GWP	1,700	1,530
Inflammability	Nonflammable (A1)	Nonflammable (A1/A1)
Toxicity	less	less
Azeotropic or Zeotropic	————	Zeotropic
Features	————	Necessary to handle carefully because of zeotropic. Working pressure is nearly equal to that of R22 (about 1.1 times).

6-7-3 DEFERENCE FROM CONVENTIONAL MODEL (R22) AND PRECAUTIONS

OIL

- Use new synthetic oils such as ester because HFC series refrigerant has less solubility with mineral oils conventionally used for R22.
- As these new synthetic oils are easily influenced by moisture and dusts, they must be treated more carefully than the conventional lubricating oils.

CAUTION

For installation/servicing, take more precautions than the case of conventional refrigerants to avoid moisture and dusts entering the refrigerant circuit. Also, for storing parts, more precautions must be taken.

COMPRESSOR

- Use better grade of material for sliding parts for securing good lubrication of sliding part as HFC refrigerant does not contain chloride.
- Review insulating materials
- Increase pressure resistance strength

CAUTION

Check if the compressor is suitable for the refrigerant type when replacing. Complete welding within 15 minutes after opening the cap when replacing.

HEAT EXCHANGER

- Review the water, contaminants controlling level
- Use thinner tube to increase pressure resistance strength (only outdoor unit) improving performance

CAUTION

During storage, due care must be taken so that foreign matters such as dust and water do not enter.

4-WAY VALVE

- Review materials

CAUTION

Check if the valve is suitable for the refrigerant type when replacing.

CHECK VALVE

- Review materials
- Change shape of pipe ends to increase pressure resistance strength

CAUTION

Check if the valve is suitable for the refrigerant type when replacing.

2, 3-WAY VALVE

- Review material O-ring, valve core seal for securing suitability with oil.

CAUTION

Check if the valve is suitable for the refrigerant type when replacing.

BALL VALVE

- Review material O-ring, valve core seal for securing suitability with oil.

CAUTION

Check if the valve is suitable for the refrigerant (model) when replacing.

DRYER

- Change desiccant (XH-6 → XH-10). Volume of desiccant is increased.

CAUTION

Complete welding within one hour after the package of dryer is opened.

PRESSURE SWITCH

- Adopt the models which can ensure higher reliability.

CAUTION

Check if the pressure switch is suitable for the refrigerant type when replacing.

OTHER PIPING

- Review the water, contaminants controlling level.
- Review thickness of pipes.

CAUTION

During storage, due care must be taken so that foreign matters such as dust and water do not enter.

Refrigerant
R407C

AIRSTAGE™

7 . APPENDING DATA 1 (UNIT)

7. APPENDING DATA1 (UNIT)

7-1 REFRIGERANT PIPE SYSTEM DIAGRAM

■ HEAT RECOVERY TYPE

● MODEL : AO90MPAMF

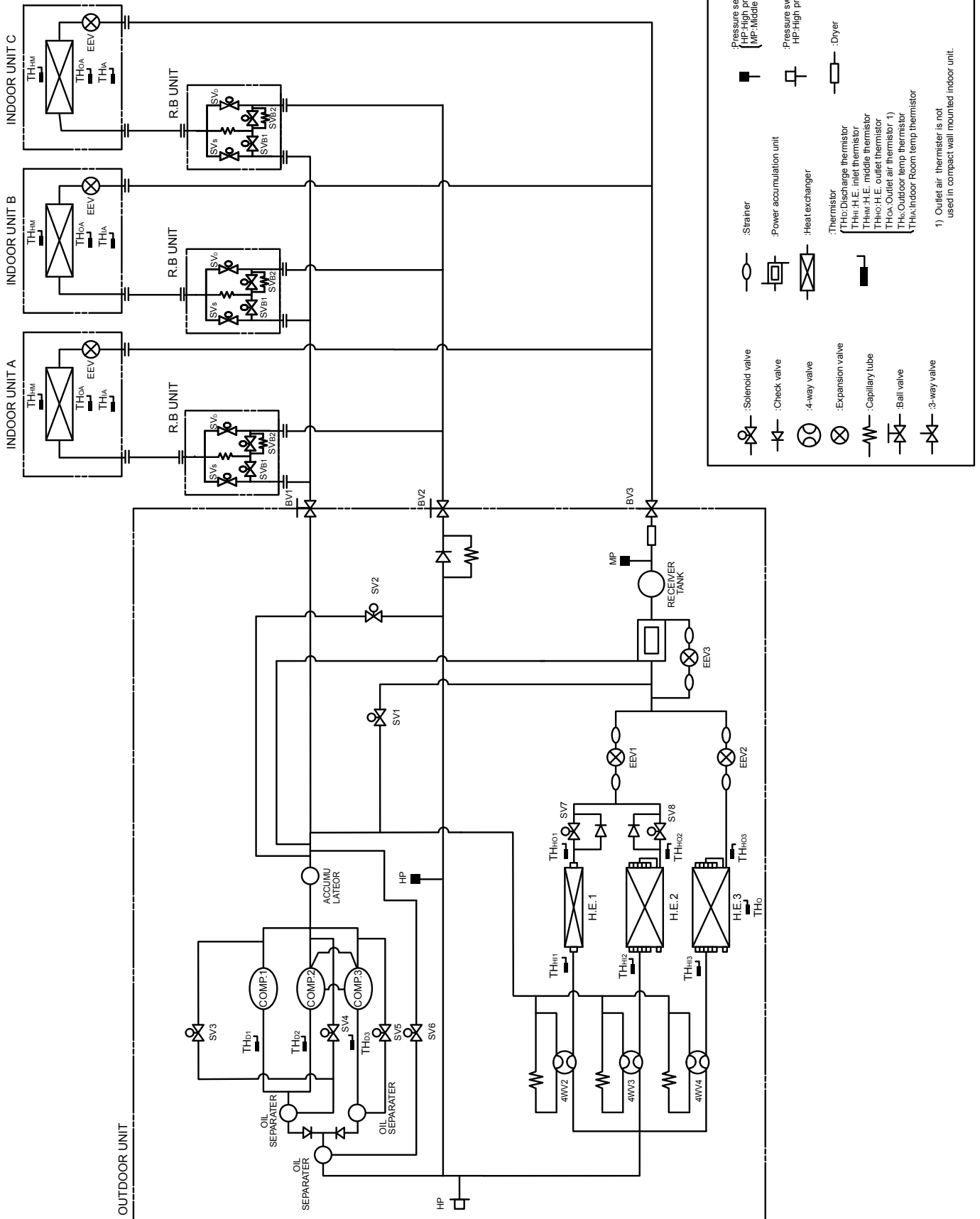

7-2 CHARACTERISTICS OF SENSORS

7-2-1 THERMISTOR

Thermistor resistance values <Indoor unit side>

1) Room temperature thermistor (TH_{OA}, TH_{IA})

Room temperature (°C)	0	2.5	5	7.5	10	12.5	15	17.5	20	22.5	25	27.5	30
Resistance value (kΩ)	33.6	29.5	25.9	22.8	20.2	17.9	15.8	14.1	12.5	11.2	10.0	9.0	8.0

Room temperature (°C)	32.5	35	37.5	40	42.5	45	47.5	50
Resistance value (kΩ)	7.2	6.5	5.9	5.3	4.8	4.3	3.9	3.6

2) Indoor heat exchanger temperature thermistor (TH_{HM})

Heat exchanger temperature (°C)	0	2.5	5	7.5	10	12.5	15	17.5	20	22.5	25	27.5	30
Resistance value (kΩ)	176.0	153.5	134.2	117.6	103.3	91.0	80.3	71.0	62.9	55.9	49.7	44.3	39.6

Heat exchanger temperature (°C)	32.5	35	37.5	40	42.5	45	47.5	50	52.5	55	57.5	60
Resistance value (kΩ)	35.4	31.7	28.5	25.6	23.1	20.8	18.8	17.1	15.5	14.1	12.8	11.6

Thermistor resistance values <Outdoor unit side>

1) Outdoor heat exchanger outlet and inlet thermistor (TH_{HO1}, TH_{HO2}, TH_{HO3}, TH_{HI01}, TH_{HI02}, TH_{HI03})

Pipe temperature (°C)	-50	-40	-30	-20	-10	-7.5	-5.0	-2.5	0	2.5	5.0	7.5	10
Resistance value (kΩ)	384.8	182.8	92.3	49.2	27.5	24.0	20.9	18.3	16.1	14.1	12.4	11.0	9.7

Pipe temperature (°C)	12.5	15.0	17.5	20	22.5	25.0	27.5	30	32.5	35	37.5	40	50
Resistance value (kΩ)	8.6	7.7	6.8	6.1	5.5	4.9	4.4	3.9	3.6	3.2	2.9	2.6	1.8

Pipe temperature (°C)	60	70	80	90	100
Resistance value (kΩ)	1.2	0.9	0.6	0.5	0.4

2) Discharge temperature thermistor (TH_{D1}, TH_{D2}, TH_{D3})

Pipe temperature (°C)	-40	-30	-20	-10	0	5.0	10	12.5	15	17.5	20	22.5	25
Resistance value (kΩ)	2183	1076	561	307	176	135	105	92.4	81.8	72.6	64.5	57.5	51.3

Pipe temperature (°C)	27.5	30	32.5	35	37.5	40	50	60	70	80	90	100	120
Resistance value (kΩ)	45.8	41.1	36.9	33.1	29.8	26.9	18.1	12.5	8.8	6.3	4.6	3.4	2.0

Pipe temperature (°C)	140	160	180
Resistance value (kΩ)	1.2	0.8	0.5

3) Outdoor temperature thermistor (TH_O)

Pipe temperature (°C)	-50	-40	-30	-20	-10	-7.5	-5.0	-2.5	0	2.5	5.0	8.0	10
Resistance value (kΩ)	859	402	200	105	58.2	50.6	44.0	38.4	33.6	29.5	25.9	22.3	20.2

Pipe temperature (°C)	12.5	15	17.5	20	22.5	25	27.5	30	32.5	35	37.5	40	50
Resistance value (kΩ)	17.9	15.8	14.1	12.5	11.2	10.0	9.0	8.0	7.2	6.5	5.9	5.3	3.6

Pipe temperature (°C)	60	70	80
Resistance value (kΩ)	2.5	1.8	1.3

7-2-2 PRESSURE SENSOR

1) Characteristics of pressure sensor

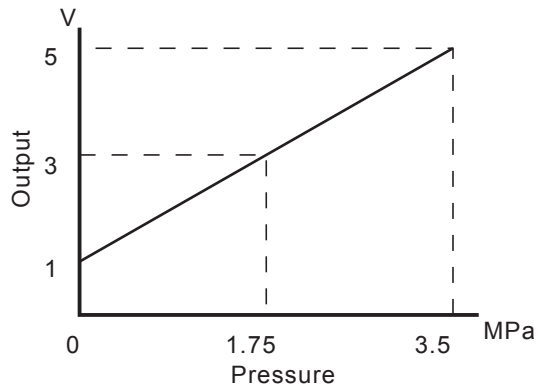

OUTPUT VOLTAGE OF THE PRESSURE SENSORS (HP,LP)

Pressure (MPa)	0.00	0.10	0.20	0.30	0.40	0.50	0.60	0.70	0.80	0.90	1.00	1.20	1.40
Output (V)	0.00	1.11	1.21	1.33	1.45	1.56	1.68	1.80	1.91	2.01	2.13	2.36	2.60

Pressure (MPa)	1.60	1.80	2.00	2.20	2.40	2.60	2.80	3.00	3.20	3.40	3.50
Output (V)	2.81	3.05	3.28	3.50	3.73	3.96	4.20	4.41	4.65	4.88	4.98

2) Check point of replacing pressure sensor

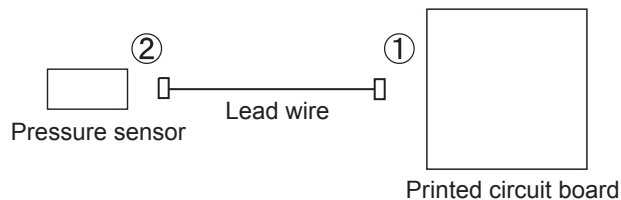

When installing the pressure sensor, connect a lead wire to the PCB (①), thereafter connect the other end of a lead wire to the pressure sensor (②). When disconnecting, do the opposite procedure. Be careful not to install other than above procedure, otherwise the pressure sensor can be failed.

7-2-3 ELECTRIC EXPANSION VALVE

When the electric expansion valve is locked cause by failure, it emits click noise. Confirming the noise emission is done by touching any implement like a screw driver.

7-2-4 RB UNIT

When the RB unit is failed, it can be concerned one of the valve such as discharge valve, suction valve and bypass is locked. The relation between open/close status of each valve of RB unit and operating mode is shown in 4-3-1.

7-2-5 OTHERS

- 1) Solving the problem is necessary since following can be occurred.
 - ① Gas leakage, capacity declining cause by gas shortage.
 - ② Dirt from the filter and the EEV.
 - ③ Capacity declining by mis-setting of the indoor unit capacity.
 - ④ Unfit of the refrigerant pipe.
 - ⑤ Increasing the indoor unit by mis-piping.
 - ⑥ Increasing the indoor unit by mis-setting the refrigerant system address.
 - ⑦ Disconnection of the transmission line.

- 2) The air conditioner operates intermittently or an error message appears.
 - ① Wiring method of the transmission line.
 - ② Loose contact of the transmission line
 - ③ Mis-selecting the transmission line.
 - ④ Over the limit of the transmission line length.
 - ⑤ Noise influences the transmission line.
 - ⑥ In case of the specified indoor unit, the indoor unit PCB is defected.
 - ⑦ In case of all units or the specified unit, the outdoor unit PCB is defected.

7-3 WIRING DIAGRAM

7-3-1 INDOOR UNIT

UNIVERSAL FLOOR / CEILING TYPE

■ MODELS : AB12, AB14, AB18, AB24

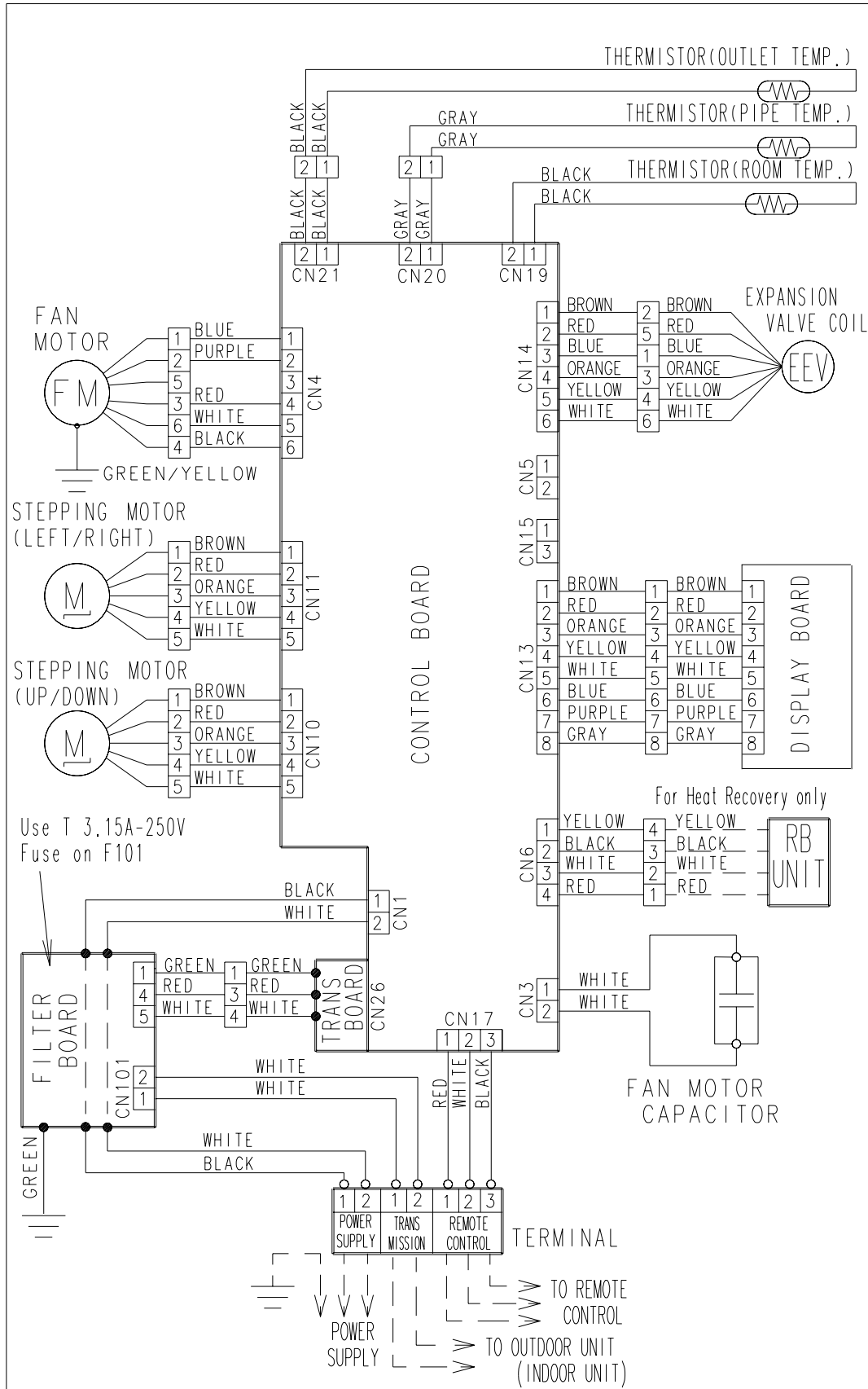

LARGE CEILING TYPE

■ MODELS : AB30, AB36, AB45, AB54

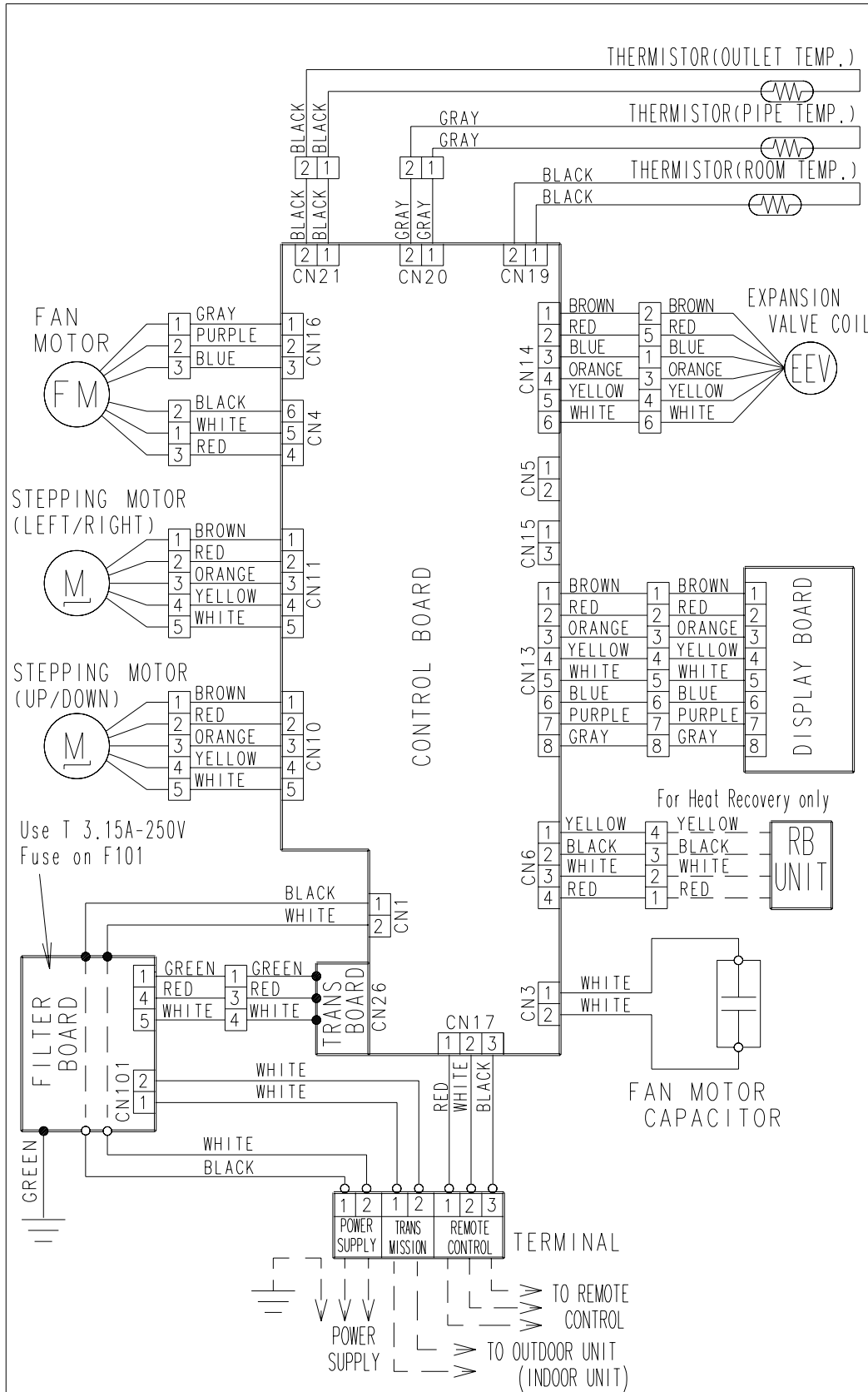

COMPACT DUCT TYPE

■ MODELS : AR7, AR9, AR12, AR14, AR18

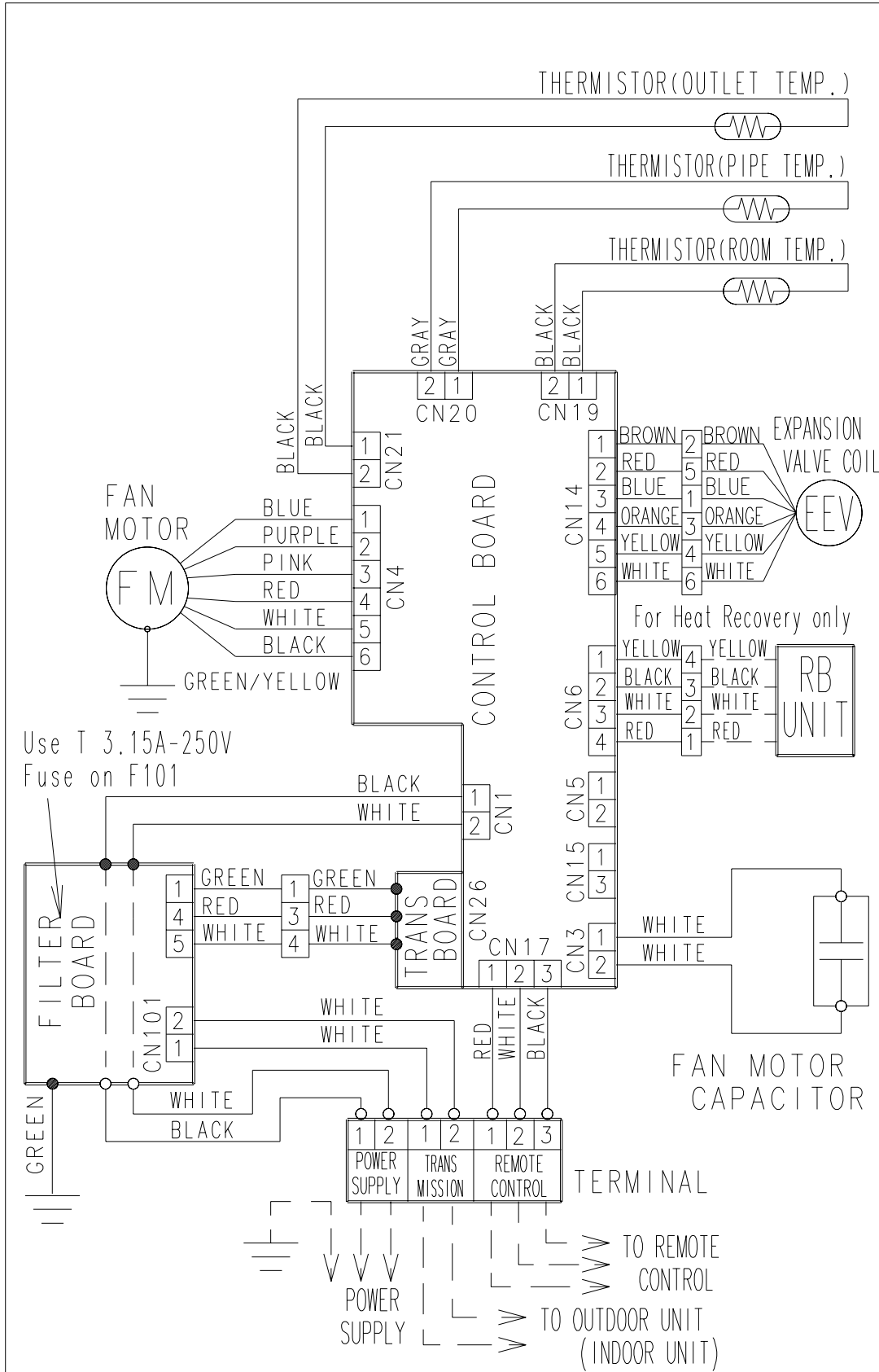

LOW STATIC PRESSURE DUCT TYPE

■ MODELS : AR25

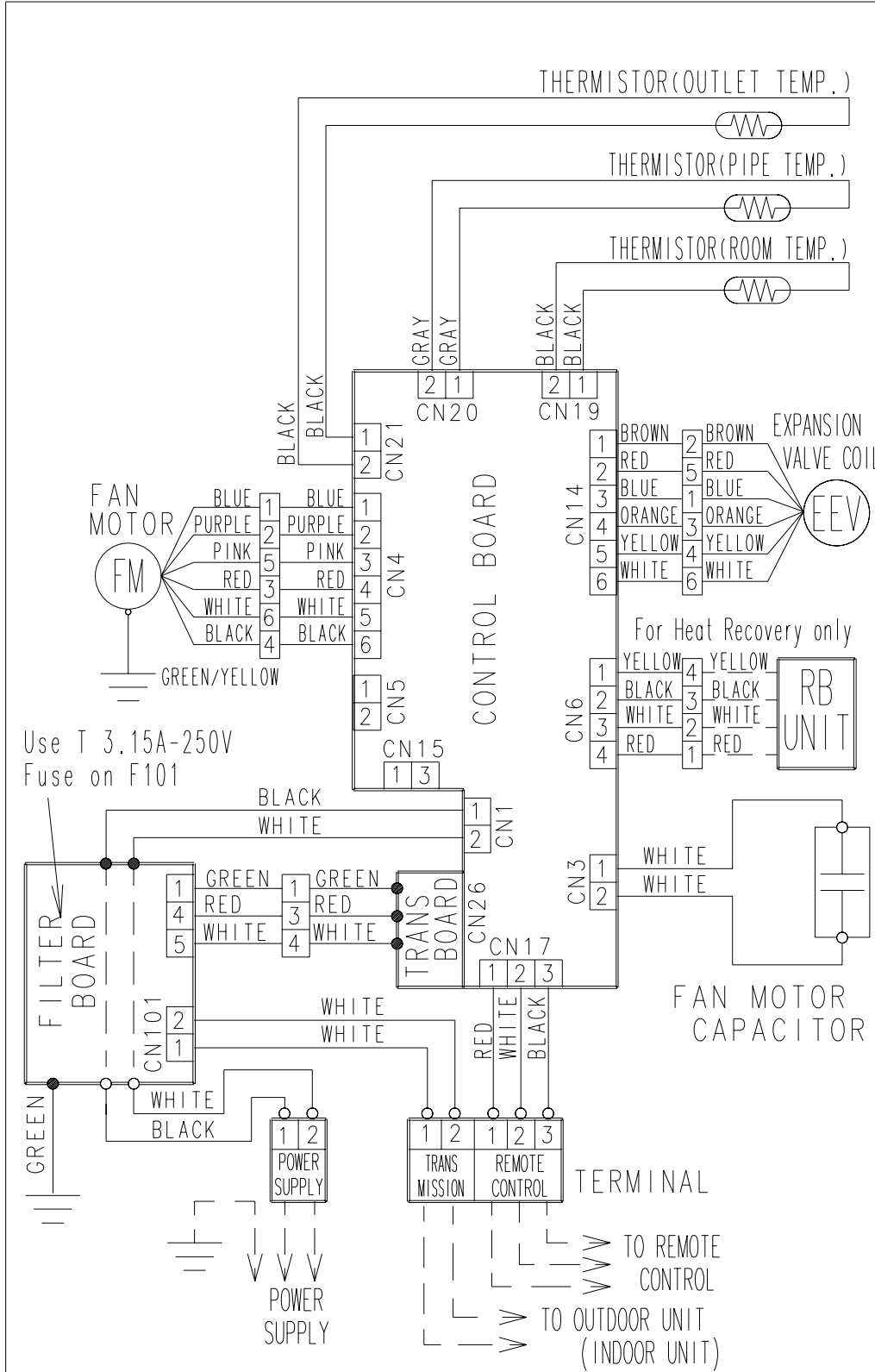

LOW STATIC PRESSURE DUCT TYPE

■ MODELS : AR30, AR36, AR45

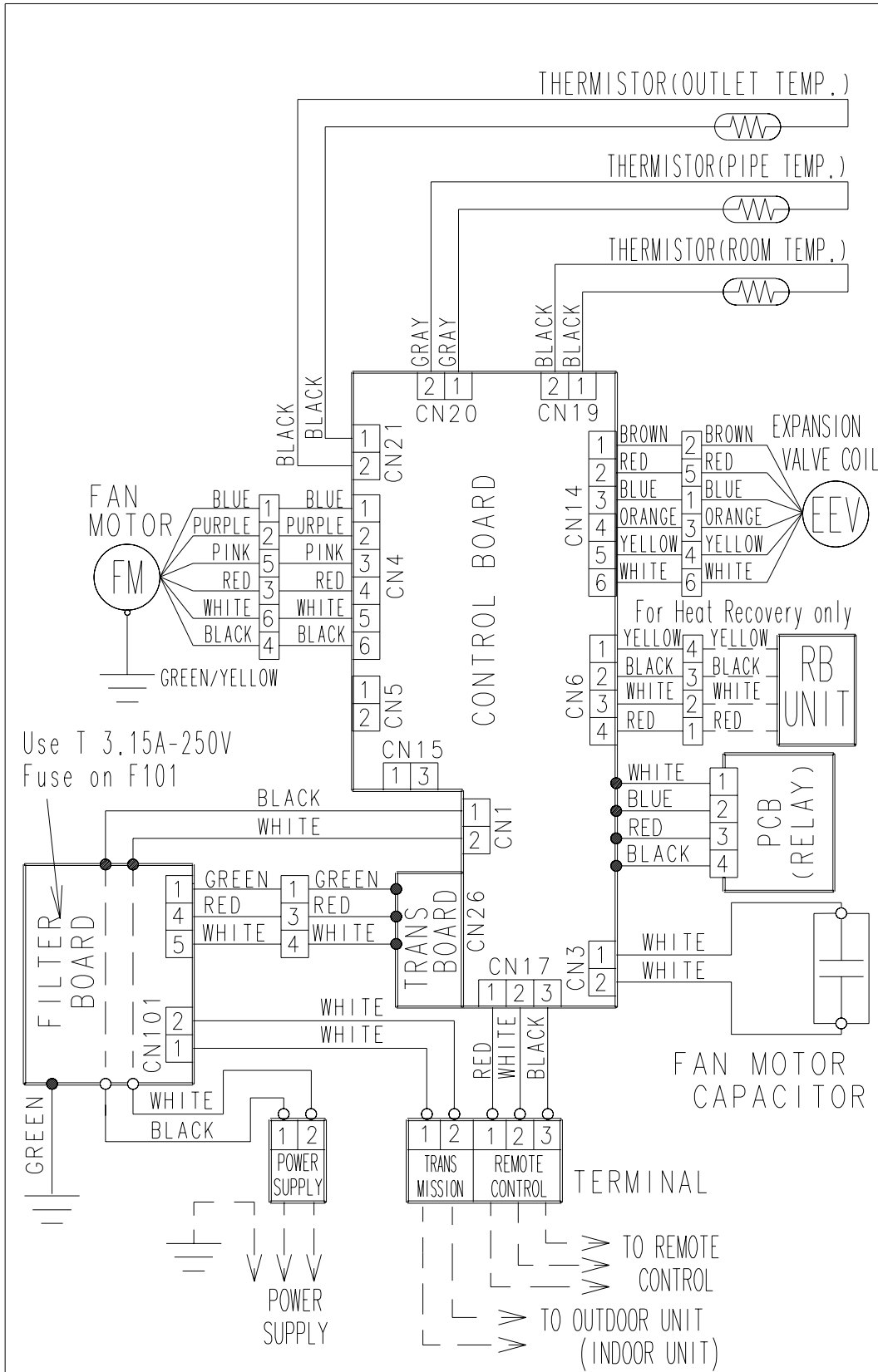

HIGH STATIC PRESSURE DUCT TYPE

■ MODELS : AR36H, AR45H, AR60H

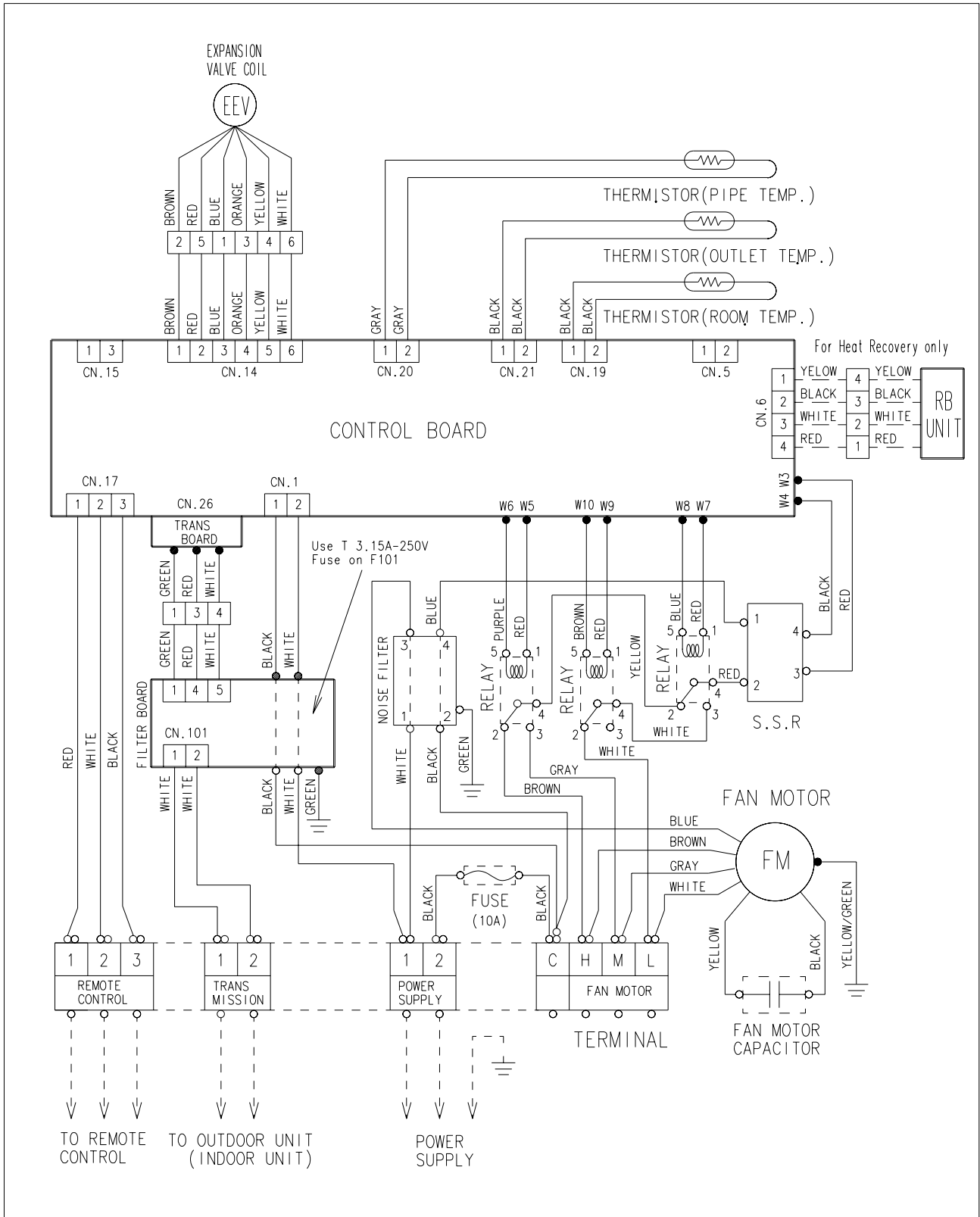

COMPACT CASSETTE TYPE

■ MODELS : AU7, AU9, AU12, AU14, AU18

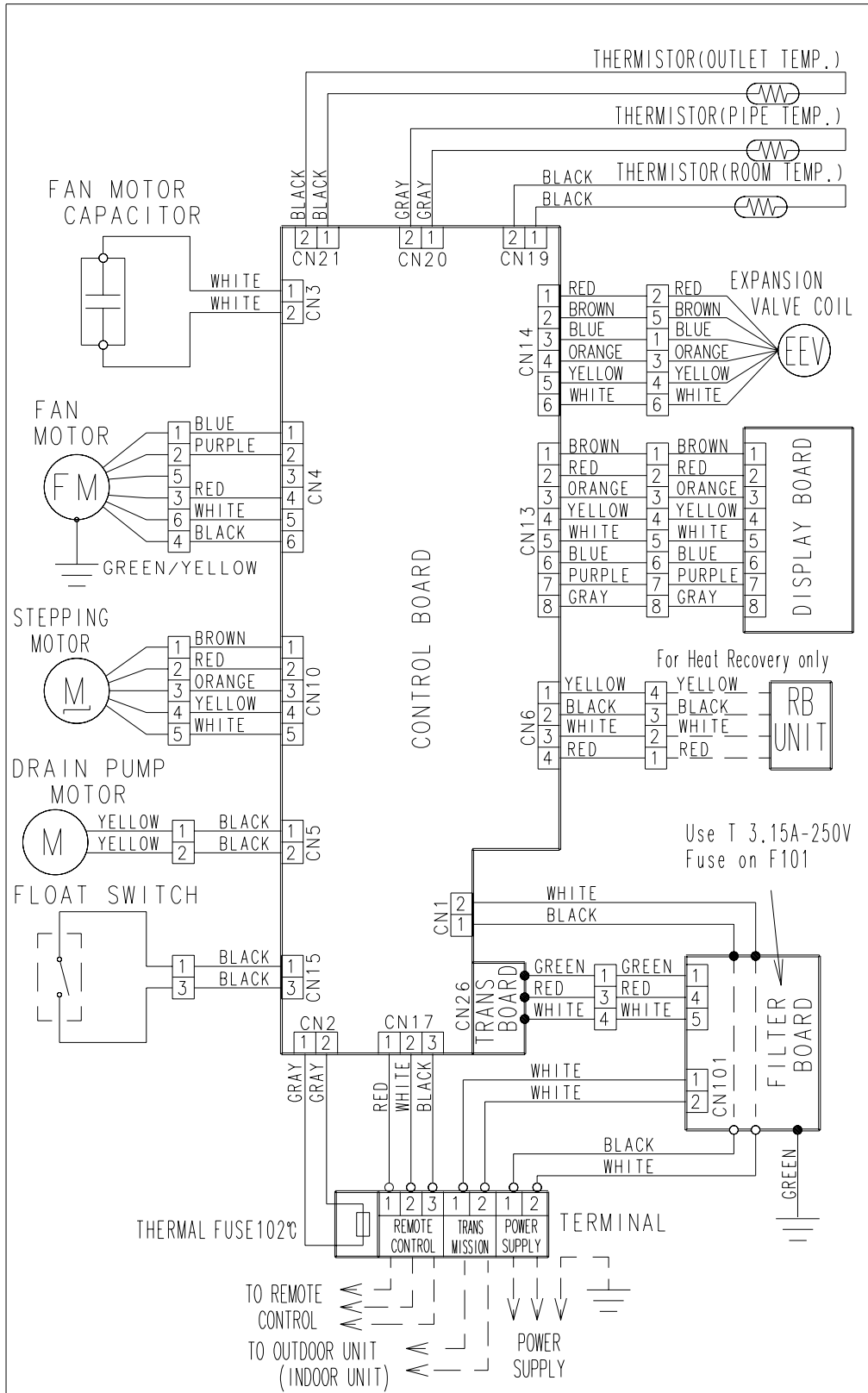

CASSETTE TYPE

■ MODELS : AU20, AU25, AU30

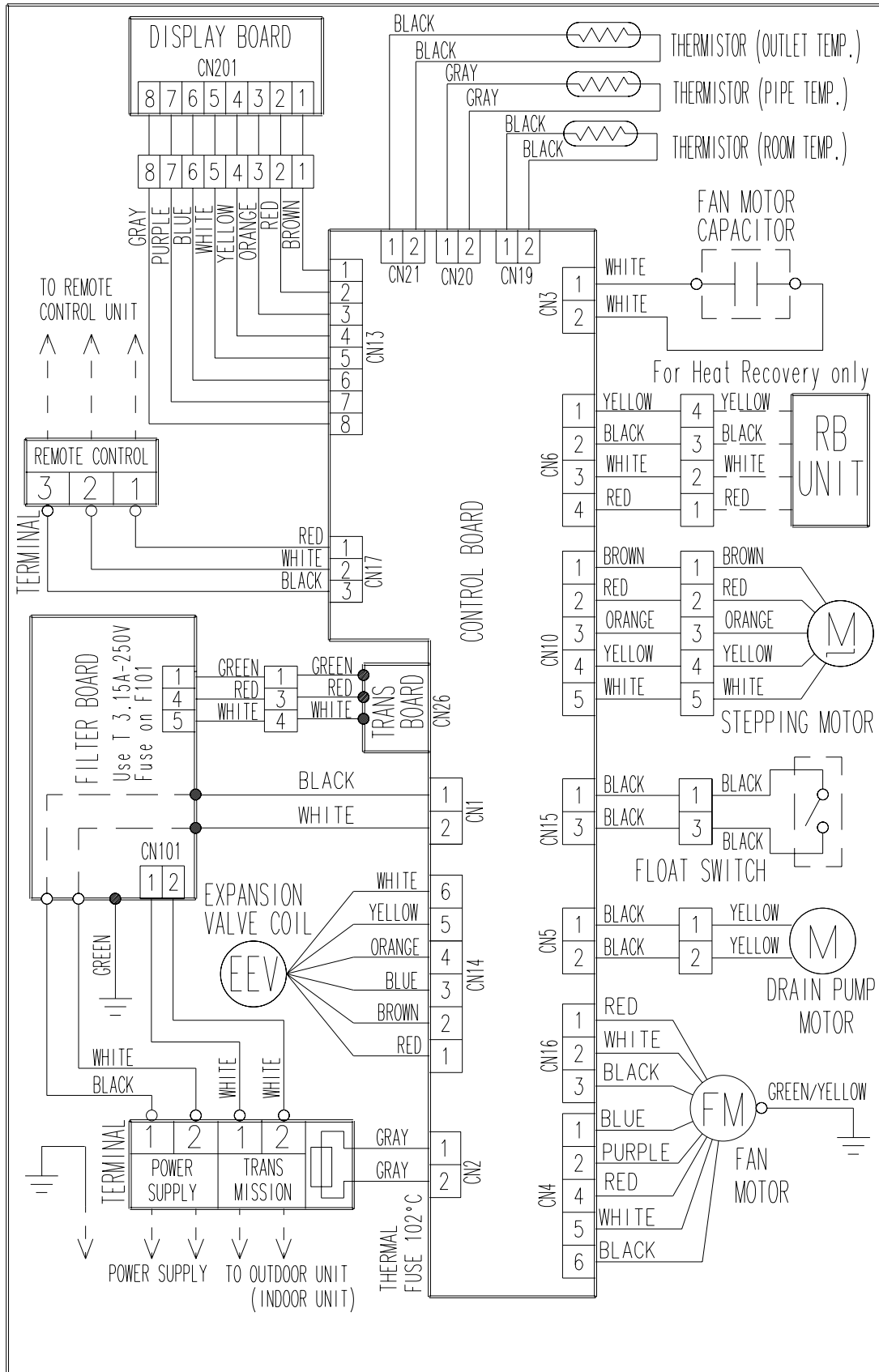

■ MODELS : AU36, AU45, AU54

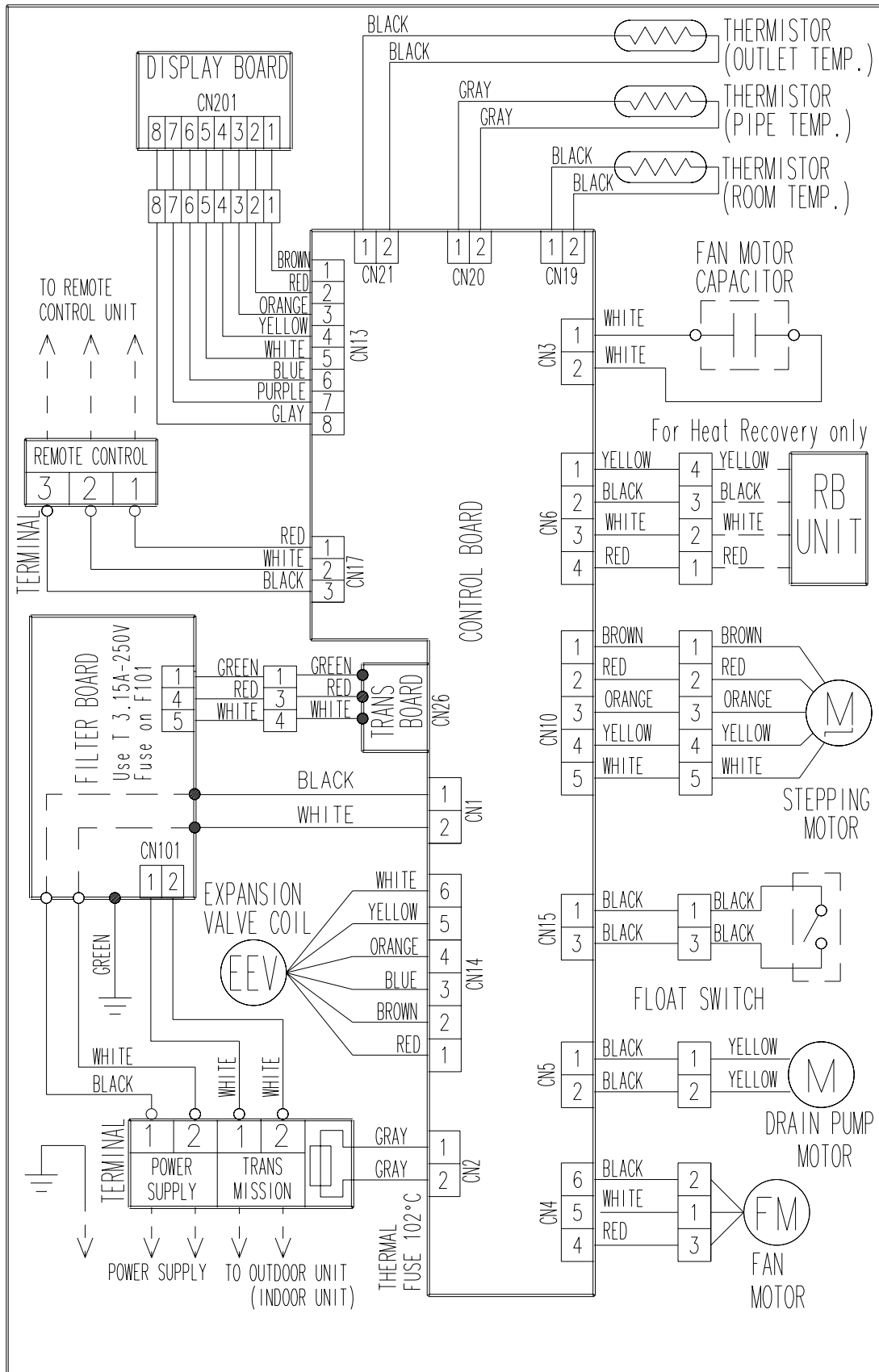

COMPACT WALL MOUNTED TYPE

■ MODELS : AS7,AS9,AS12,AS14

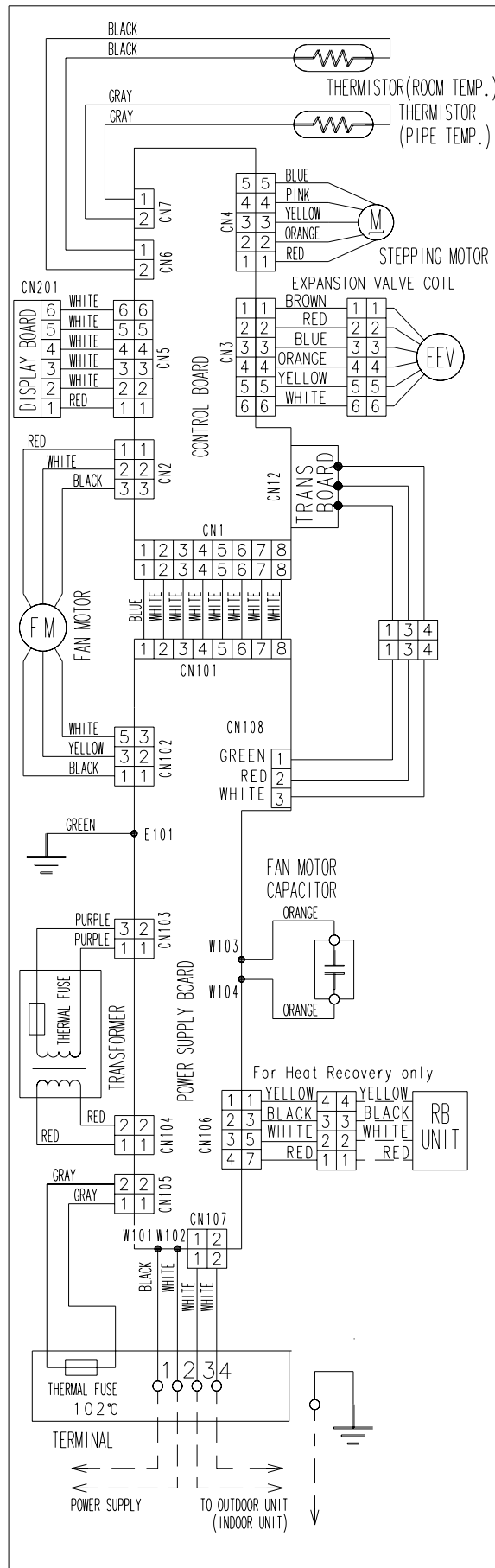

WALL MOUNTED TYPE

■ MODELS : AS18, AS24, AS30

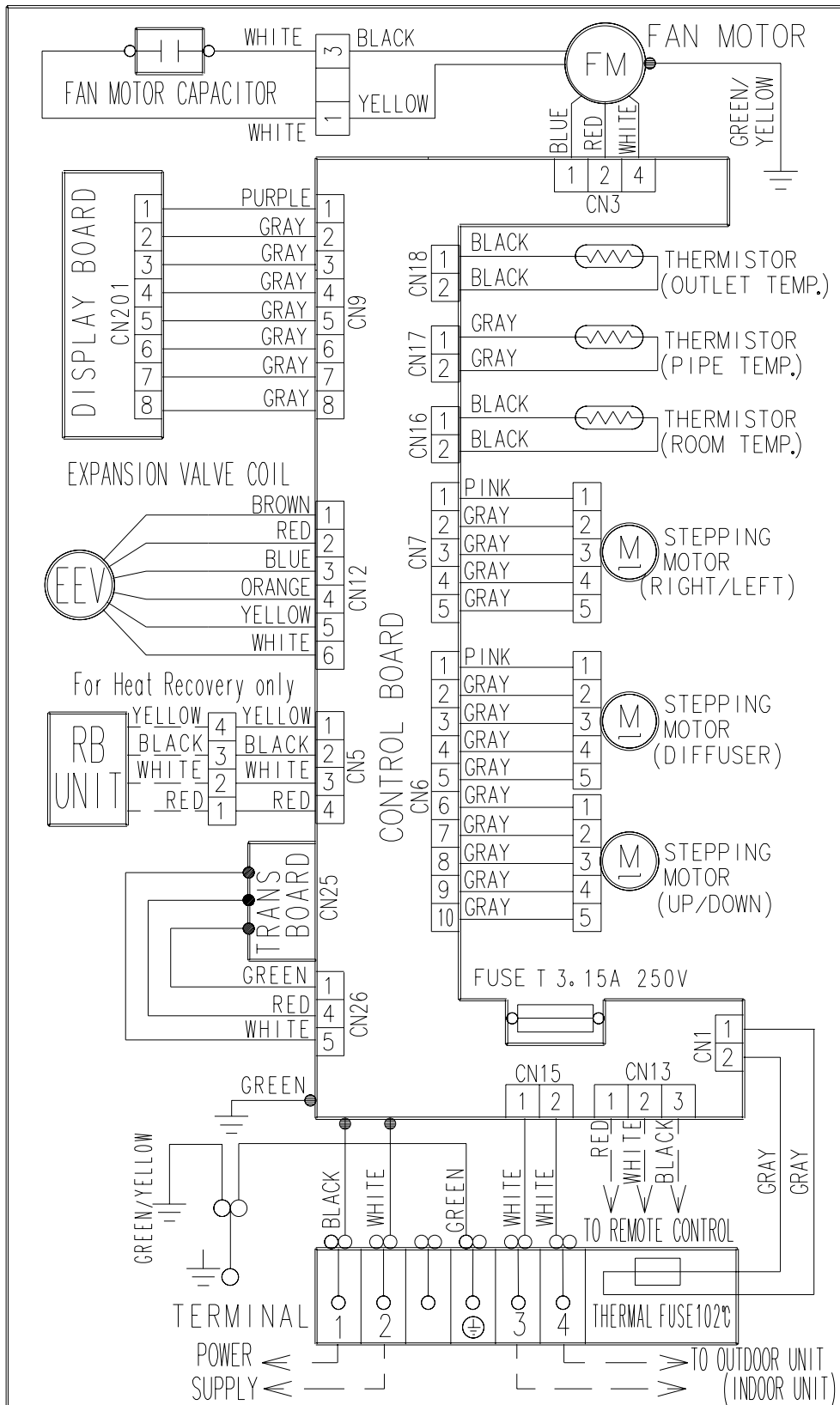

CEILING WALL TYPE

■ MODELS : AW7, AW9, AW14, AW18, AW24, AW30

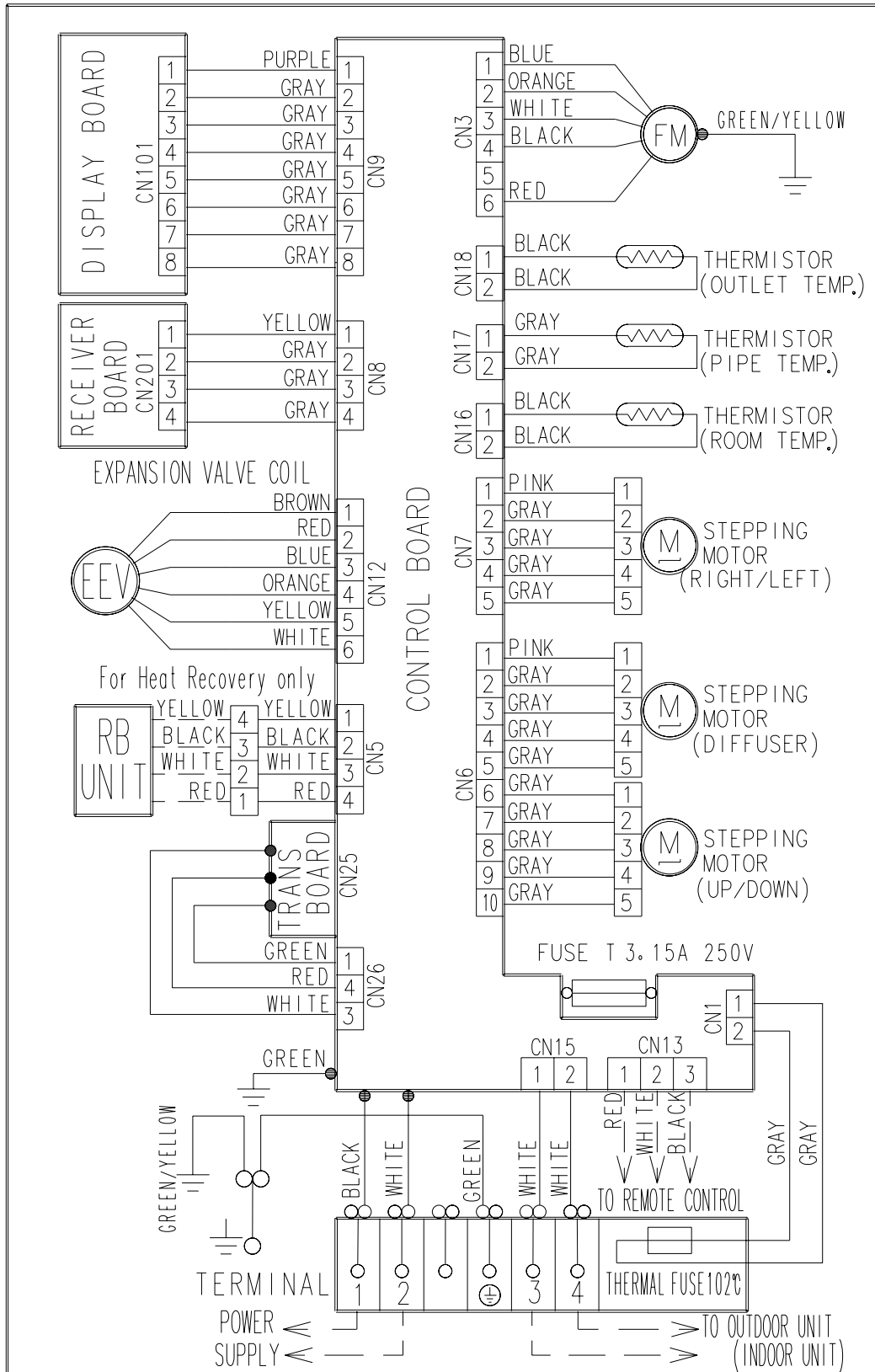

7-3-2 OUTDOOR UNIT

MODEL : AO90MPAMF HEAT RECOVERY TYPE

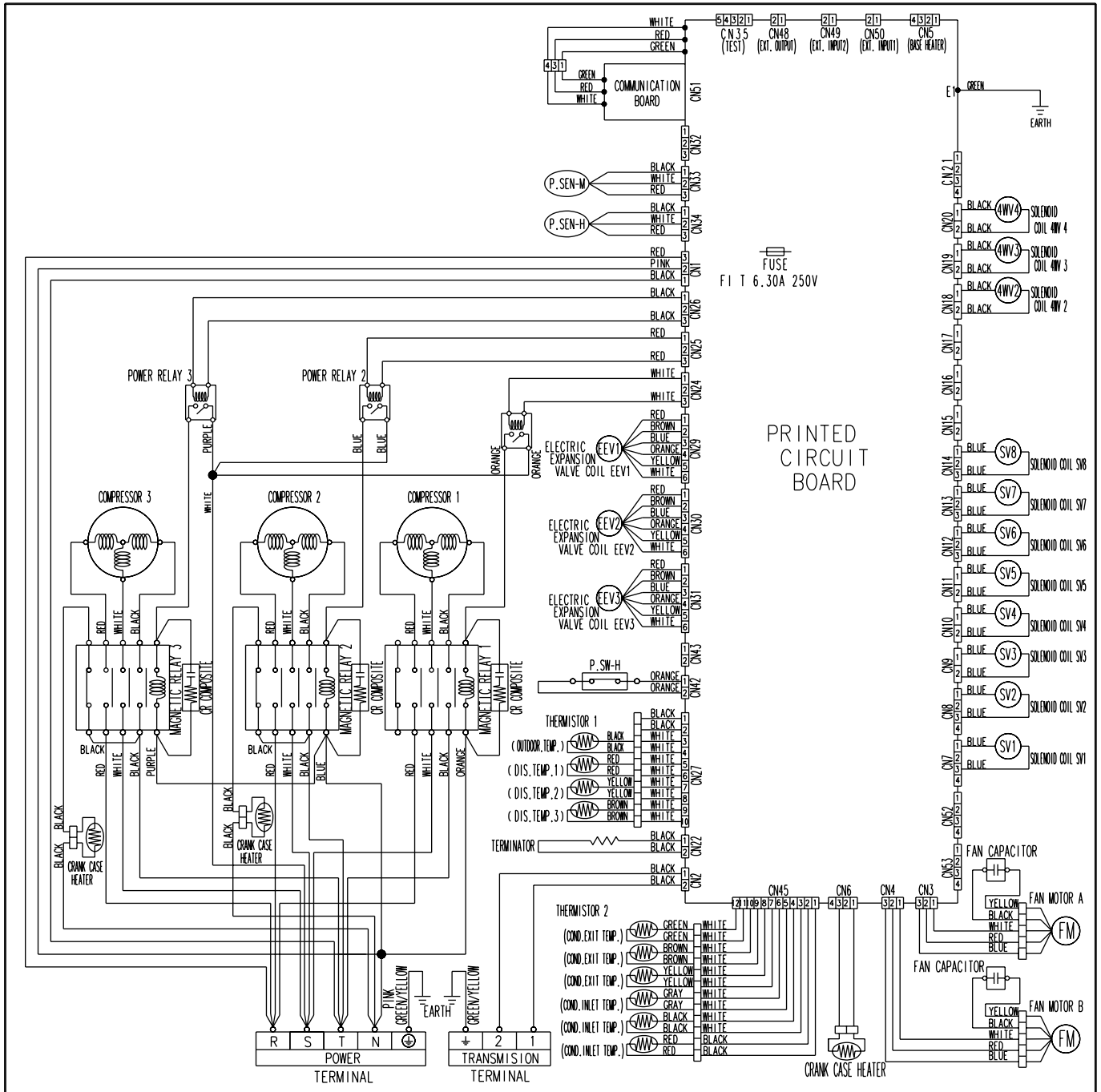

7-4 OUTDOOR INTERNAL LAYOUT

OUTDOOR UNIT INTERNAL LAYOUT

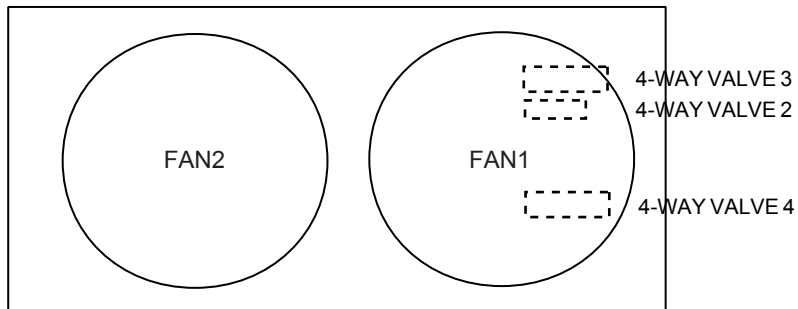

(FRONT)

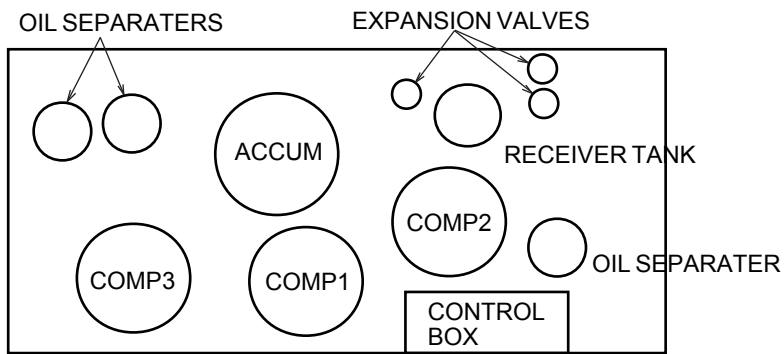

(FRONT)

OUTDOOR UNIT CONTROL BOX INTERNAL LAYOUT

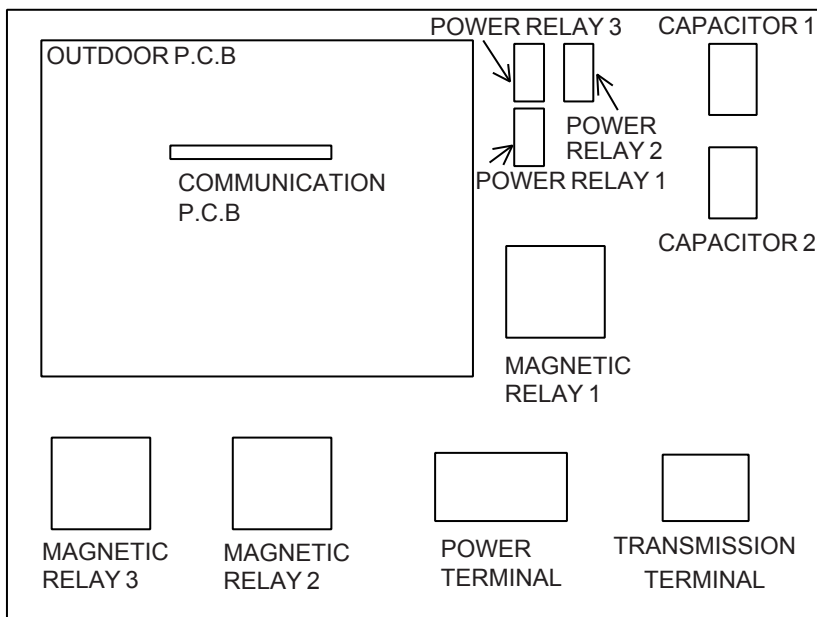

7-5 MODEL DESIGNATION

● OUTDOOR UNIT

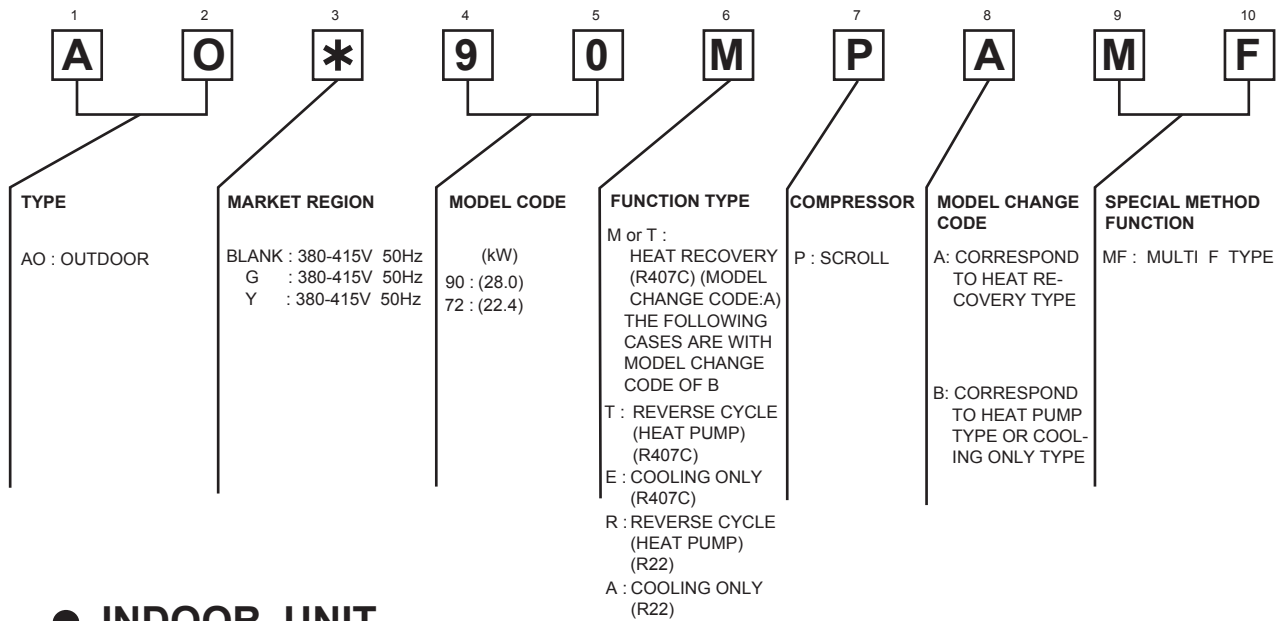

● INDOOR UNIT

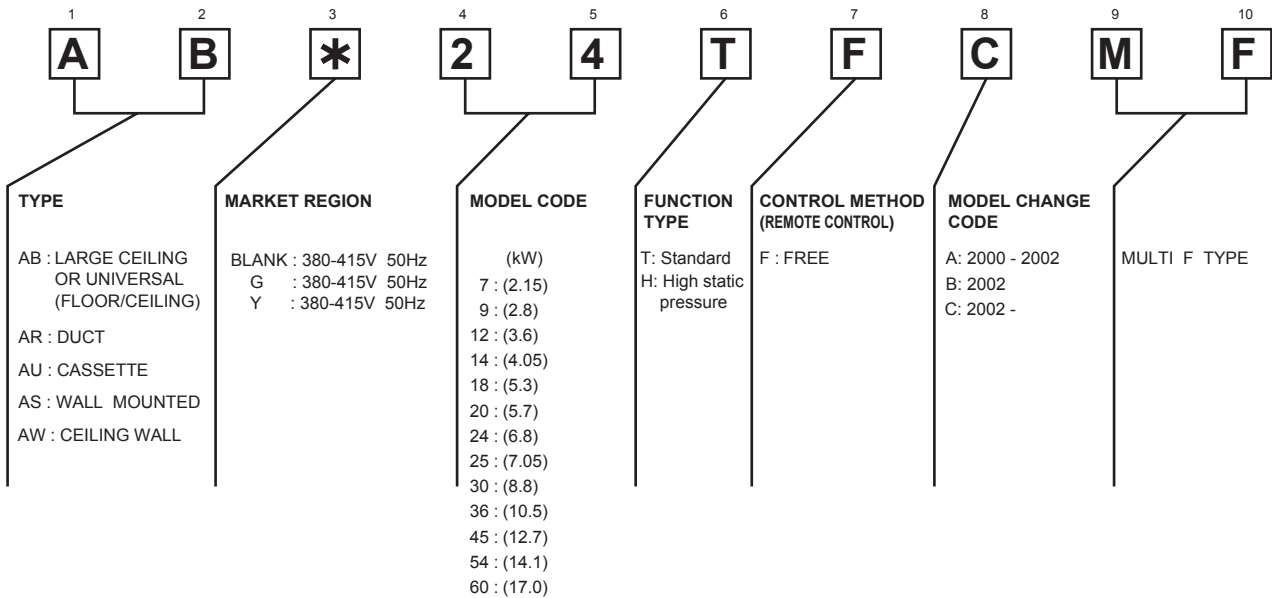

● REMARK

This manual corresponds to the outdoor unit of heat recovery type (Model: AO90MPAMF) and the indoor units model with model change code of C.



FUJITSU GENERAL LIMITED

1116, Suenaga, Takatsu-ku, Kawasaki 213-8502, Japan

Product specifications are subject to change without notice.

"**AIRSTAGE**" is a worldwide trademark of FUJITSU GENERAL LIMITED.

Copyright © 2003 Fujitsu General Limited. All rights reserved.